

OFFICE COPY

APPEALS

A DESIGN GUIDE FOR RESIDENTIAL AREAS



ESSEX COUNTY COUNCIL



A DESIGN GUIDE FOR RESIDENTIAL AREAS

PLANNING DEPT
EPPING FOREST DISTRICT COUNCIL
OLD STATION ROAD
LOUGHTON
ESSEX.

ESSEX COUNTY COUNCIL : MAY 1983

£12.50*

*Inclusive of separate document "Highway Standards 1980"

FOREWORD TO THE 1983 EDITION

Nearly ten years have passed since the Design Guide was first published and now in response to a continuing demand for copies we have decided to reprint.

During the late 1970's the Highway Standards that had proved such a decisive part of the 1973 guide were further improved in the light of the D.O.E. Bulletin 32. The new Highway Standards prepared by a working party of District and County Officers were published as a separate document in November 1980. Since these supersede those in the Guide a copy is included with it.

Over the last ten years some designers and developers have responded to the freedom and stimulus the Guide gives. A number of first rate schemes have been built which would have been impossible before 1973 and a selection are listed in Appendix C. At the same time, however, a new minimum level of acceptance has been found by developers which in turn is creating a new kind of 'anywhere' housing, different from that of the 60's, but still as boring to live in and almost as visually sterile. 'Built forms set to satisfactorily enclose spaces of individual identity' are achieved infrequently. Often we see a scheme advertised as conforming with this Guide, which patently it does not.

It is interesting to note that the schemes illustrated as case studies deal almost entirely with three-bedroom houses. That was the situation and market in the early 1970's. Now there is a great demand for smaller homes, which require new design solutions and some excellent schemes have been built at the County Council's new town at South Woodham Ferrers and elsewhere. The mix of small and large dwellings is a new challenge to the imaginative designer and fortunately there are a few such designers working in Essex. We wish them well.



January 1983

COUNTY PLANNER

© County Council of Essex 1973

First published December 1973

Reprinted April 1975

Reprinted May 1983

Printed in Great Britain by The Anchor Press Ltd, and bound
by Wm. Brendon & Son Ltd, both of Tiptree, Essex

FOREWORD TO THE 1983 EDITION

Nearly ten years have passed since the Design Guide was first published and now in response to a continuing demand for copies we have decided to reprint.

During the late 1970's the Highway Standards that had proved such a decisive part of the 1973 guide were further improved in the light of the D.O.E. Bulletin 32. The new Highway Standards prepared by a working party of District and County Officers were published as a separate document in November 1980. Since these supersede those in the Guide a copy is included with it.

Over the last ten years some designers and developers have responded to the freedom and stimulus the Guide gives. A number of first rate schemes have been built which would have been impossible before 1973 and a selection are listed in Appendix C. At the same time, however, a new minimum level of acceptance has been found by developers which in turn is creating a new kind of 'anywhere' housing, different from that of the 60's, but still as boring to live in and almost as visually sterile. 'Built forms set to satisfactorily enclose spaces of individual identity' are achieved infrequently. Often we see a scheme advertised as conforming with this Guide, which patently it does not.

It is interesting to note that the schemes illustrated as case studies deal almost entirely with three-bedroom houses. That was the situation and market in the early 1970's. Now there is a great demand for smaller homes, which require new design solutions and some excellent schemes have been built at the County Council's new town at South Woodham Ferrers and elsewhere. The mix of small and large dwellings is a new challenge to the imaginative designer and fortunately there are a few such designers working in Essex. We wish them well.

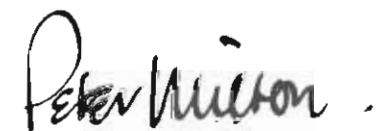

January 1983

COUNTY PLANNER

© County Council of Essex 1973

First published December 1973

Reprinted April 1975

Reprinted May 1983

Printed in Great Britain by The Anchor Press Ltd, and bound
by Wm. Brendon & Son Ltd, both of Tiptree, Essex

FOREWORD

1. Good planning does not, unfortunately, always lead to a good environment since the form and layout of most development is influenced by many additional factors which can be detrimental and give rise to mediocrity or, in extreme cases, to building which is offensive. While much can be done to improve the quality of development through the statutory process of planning control, this can be a source of friction and wasteful of time and scarce resources if there is a lack of understanding between the public and the planners.

2. By putting forward a clear and constructive statement of their policy for general guidance, the Essex County Council have made a bold and imaginative move to establish a firm basis of understanding between would-be developers and the Committees and officials having responsibility for measures of control. All must surely gain real benefit from this initiative which could, I believe, reduce the time now required for the developer to obtain permission and, hopefully, the number of appeals against the refusal of permission.

3. I am glad to see that the Council propose to relax some longstanding constraints, particularly concerning roads. It should now be possible to design more economical and attractive forms of development in certain situations. I look forward to seeing the practical effect of these changes.



December 1973

SECRETARY OF STATE FOR THE ENVIRONMENT

INTRODUCTION

Few Essex people are happy at the form which post-war housing development in the County has taken. It has a dreary suburban uniformity and lacks any specific Essex characteristics.

In an effort to improve this situation, a new planning policy has been adopted. In order to give the building industry time to absorb the proposed changes it was agreed that the policy should not be operative until the publication of this document.

The 'Design Guide for Residential Areas' now replaces the existing county booklet 'The Density, Form and Character of Residential Development'.

The aim of the new policy is to establish a planning framework within which a more varied and imaginative approach to housing area design can be fostered. The result should be housing schemes which are better to live in and to live with.

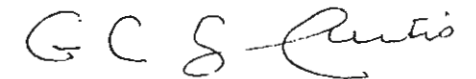

December 1973

G.C.S. Curtis O.B.E. M.A.

CHAIRMAN OF THE PLANNING COMMITTEE

CONTENTS

	PART I POLICY	9
	1.0 Planning Policies	10
	2.0 Design Policies—Physical	12
	3.0 Design Policies—Visual	15
	PART II PRACTICE NOTES	17
SECTION	1.0 THE PLANNING CONTEXT	19
	1.1 Local Plans	22
	1.2 Density	22
SECTION	2.0 PHYSICAL CRITERIA	25
	2.1 The House Envelope	26
	2.11 Internal space standards	
	2.12 Extendable houses	
	2.13 Internal privacy	
	2.14 Sound insulation	
	2.15 Sunlight and Daylight	
	2.2 The house curtilage	33
	2.21 'Private Zone'	
	2.22 Minimum garden area	
	2.23 Sitting out areas for flats	
	2.3 Services	35
	2.31 General services to dwellings	
	2.32 Access	
	2.321 Pedestrian movement	
	2.322 Vehicular movement	
	2.323 Car parking	
	2.324 Servicing	
	2.33 Community facilities	
	2.4 Adoption standards and maintenance	58
SECTION	3.0 VISUAL CRITERIA	61
	3.1 The principles of spatial organisation	61
	3.2 The principles of landscape dominated design	63
	3.21 Informal arcadia	
	3.22 Formal arcadia	
	3.3 The principles of urban design	64
	3.31 Spatial enclosure	
	3.32 Architectural composition within the urban framework	
	3.4 Design of buildings within the urban framework	71
	3.41 Regional character	
	3.42 Local materials	
	3.43 House design	
	3.44 Building design principles	

SECTION

4.0 CASE STUDIES	83
4.1 Aspects of the design process	83
4.11 Clients brief	
4.12 Site characteristics	
4.13 Planning and design policy constraints	
4.14 Some techniques of Landscape Dominated Design	
4.141 Informal arcadia	
4.142 Formal arcadia	
4.143 Arcadia planting guide	
4.15 Some techniques of Urban Design	
4.151 Roads and street architecture	
4.152 Space between buildings	
4.2 Low density case study: Informal Arcadia	99
4.21 Site features	
4.22 Unacceptable layout	
4.23 Suggested alternative layout	
4.3 Medium density case study: Urban infill	103
4.31 Site features	
4.32 Unacceptable scheme	
4.33 Suggested alternative layout	
4.4 Medium/high density case study: Flats development	107
4.41 Site features	
4.42 Unacceptable flats scheme	
4.43 Suggested alternative layout	
4.5 Estate layout case study	110
4.51 Unacceptable scheme	
4.52 Suggested alternative layout	
4.521 Hierarchy of routes	
4.522 Garaging and parking	
4.523 Adoption areas and dwelling types	
4.53 Basic plans	
4.54 Elevations, sections and perspectives	

SECTION APPENDICES

5.0 CHECKLIST DESIGN CRITERIA	127
(A) The measurement of effective height	128
(B) Basic design theory	130
(C) Design Guide Schemes Constructed	132-3
Acknowledgements	134-5
Bibliography	136

NOTE

- (1) The colour photographs on pages 24 and 60 show schemes designed after consultation with the County Planner.
- (2) Most metric dimensions on drawings have been shortened, eg 2.100m to 2.1m in order that the imperial equivalent can be included, wherever possible.

PART 1 POLICIES



PHOTOGRAPH - left
Child at Melbourne Cedars, a housing scheme, Chelmsford
Architect F. A. Aspinall of Scott & Jaques, Chartered Architects,
Shenfield, Essex

Paragraph 26, part iv, of the Written Statement accompanying the County Development Plan First Review sets out the County Council's planning policy to be followed in the control of development in residential areas as follows:—

RESIDENTIAL DEVELOPMENT

It is intended that:—

- (i) there shall be a high standard of design in the layout of residential areas and in the buildings themselves;
- (ii) existing and proposed new residential areas shall, so far as is practicable, be separate from the main flows of through traffic;
- (iii) there shall be diversity in the density of development, in the form of buildings, and in the size and type of dwellings in all neighbourhoods;
- (iv) in deciding upon the density of development, the diversity in form and the proportionate number of different sizes and types of dwellings, the Council will take account of the following factors:—
 - (a) the need for healthy, convenient and pleasant conditions;
 - (b) the need to meet a wide diversity of demand;
 - (c) economy in the use of land;
 - (d) economy in public services;
- (v) provision shall be made for an adequate number of garages, for the parking of vehicles off the highway, and for such ancillary buildings and uses as churches, schools, playing fields and public gardens and other requirements of the local community;
- (vi) in the expansion of towns in Outer Essex, the net density shall ordinarily be within the range of 5 to 30 dwellings to the acre, with an average in new neighbourhoods of between 13 and 15 to the acre. In partly developed residential areas, the density shall be as high as is compatible with the surrounding development and the general character of the area;

- (vii) in the redevelopment of the inner areas of towns in Outer Essex, higher net densities shall ordinarily be adopted, up to a maximum of 35 dwellings per acre where the following four conditions apply:—
 - (a) there is adequate public open space nearby;
 - (b) the site is within or adjoining the central area of the town;
 - (c) effective means are provided for the separation of pedestrians from main road traffic; and
 - (d) there is good public transport to the site.
- (viii) in areas intended for large-scale development, permission for development of a small area will only be given where it can be shown to the satisfaction of the Council that the proposals can fit in with a general layout for the area;
- (ix) redevelopment, whether it be in areas of bad layout or obsolete development, or in areas of density lower than is appropriate in current conditions, shall be designed and implemented in reasonably large units to facilitate good standards of layout and full use of available land, and not to prejudice the satisfactory redevelopment of adjoining land. Permission will not normally be given for the redevelopment of small sites where these objectives could not be achieved;
- (x) in the towns beyond the Metropolitan Green Belt the growth of population and employment shall be in accord. To that end the employment situation and proposals providing new sources of employment will be considered by the Council as material factors in the consideration of proposals for residential development.

Approved by the County Planning Committee
Minute 21 January, 1973

2.1

The House Envelope**2.11 Internal Space Standards**

New housing should normally be designed to at least the minimum 'Parker Morris' space standards, as prescribed in the report 'Homes for Today and Tomorrow'.

2.12 Extendable Houses

Where homes are proposed smaller than the recommended space standards would provide, then a satisfactory means of extending the property up to the required standard will need to be indicated on the initial planning application.

2.13 Internal Privacy

On the 'public' side of the dwelling, a reasonable degree of internal privacy shall be achieved for living rooms.

On the 'private zone' side of the dwelling, a high degree of internal privacy shall be provided for living rooms. If a living room is overlooked from an opposing dwelling or curtilage, the minimum 'eye to eye' distance shall be 35 m.

2.14 Sound Insulation

The design and layout of new housing areas should normally be such as to ensure that the immediate external noise environment to any dwelling does not exceed 70dB(A) on the (L10) index.* Any new dwelling which is likely to be affected by noise ratings which exceed this figure shall be so designed as to ensure that the internal noise level does not exceed 50dB(A).

(*D. of E. Planning Bulletin 26)

2.15 Sunlight and Daylight

The design and layout of buildings shall ensure adequate daylighting levels within rooms and that an acceptable amount of sunlight can reach into each dwelling curtilage in accordance with standards recommended by the D. of E.

2.2

The House Curtilage**2.21 'Private Zone'**

New houses shall have an outdoor sitting area not overlooked by adjacent or opposing outdoor sitting areas or living rooms; this requirement to be achieved by the design and layout of above eye level permanent structures and walls.

2.22 Minimum Garden Area

Houses, when built, shall have a minimum 'private zone' garden area of 100 sq. m.

Exceptions to this policy will be

- (i) single storey patio housing—where a walled patio area of 50 sq. m. minimum will be required, a substantial proportion of which shall be paved.
- (ii) dwellings contained within a substantial area of well landscaped and properly maintained communal open space.

2.3

Services**2.31 General Services to Dwellings**

All services to dwellings shall be provided in a technically and visually satisfactory manner.

2.321 Pedestrian Movement

Within new housing areas pedestrian movement shall be made convenient, safe and pleasant, by the provision of carefully positioned and well designed 'pedestrian spine routes' and 'local access footpaths'.

2.322 Vehicular Movement

Within new housing areas, vehicular movement shall be made convenient, safe and pleasant by the provision of

- (i) a road system segregated from through traffic flows;
- (ii) a clearly defined hierarchy of routes, with roads differing in size, alignment and standard according to the designed speed and volume of traffic they are intended to carry.

2.323 Car Parking

Within new housing areas, car parking in accordance with the Planning Committee's car parking policy and vehicular servicing shall be provided for residents and visitors, in a manner which is both convenient and visually satisfactory.

2.33 Community Facilities

In new housing areas where a significant number of dwellings employ exceptions (i) and (ii) in relation to the minimum garden area (policy no. 2.22), conveniently located and appropriately designed children's play spaces shall be provided.

2.4

Adoption Standards and Maintenance

It is the policy of the County Council to encourage Local Authorities to adopt and maintain those public areas essential to the appearance and functioning of housing estates. Where public adoption is not practical, alternative arrangements shall be required to ensure the proper maintenance of such areas.

3.0

DESIGN POLICIES - VISUAL

Approved by the County Planning Committee
Minute 21 January, 1973

3.1

The Principles of Spatial Organisation

New housing areas shall create a visually satisfactory environment, achieved by employing either the principles of:—

- (i) buildings set within a dominant landscape of a character indigenous to Essex; or
- (ii) built forms set to satisfactorily enclose spaces of individual identity.

3.4

Design of Buildings within the Urban Framework

3.41 Regional Character

To perpetuate the unique building character of the county and to re-establish local identity, development shall generally employ external materials which are sympathetic in colour and texture to the vernacular range of Essex materials.

3.44 Building Design Principles

Individual buildings shall be well designed of themselves and have adequate regard for their setting by

- (i) the building being designed to form part of the larger composition of the area in which it is situated;
- (ii) the building using suitable external materials for the location in which it is situated;
- (iii) the volumes making up the block form of the building being proportioned and related to form a satisfactory composition;
- (iv) the external materials being used in a visually appropriate manner;
- (v) the fenestration being well proportioned and well related within the elevation and also being sympathetic to adjacent buildings;
- (vi) architectural detailing being used to reinforce the character required by the design and its location.

PART 2
PRACTICE NOTES

In many areas of Essex, residential building has begun to erode the quality of the built environment and detract from the unique character of many of our towns and villages. Fig. 1.0a.

With singularly few exceptions, recent housing developments in the county are depressingly characterless and 'subtopian' in appearance: 'prairie planning', wide open spaces dotted with dwarf trees; anywhere type houses—ignorant of the local vernacular tradition—packaged together in a manner devoid of identity or sense of place. Figs. 1.0b and c. Far too often at the rear of such properties are cramped back gardens, overlooked by neighbours, lacking in reasonable privacy. Figs. 1.0d and e.

In view of the amount of new housing which will be built in Essex in the course of the next decade, it is essential that an improvement is made over the present situation.

What constitutes good design has far too often been written off as *a matter of opinion or taste* with a subsequent cheapening of the visual environment. By setting out a clearly related structure of planning and design policies, it is hoped that better housing schemes and a greater consistency in the granting of planning permissions will result.

As the basis for this, the new policy is further explained and supplemented by the following practice notes.

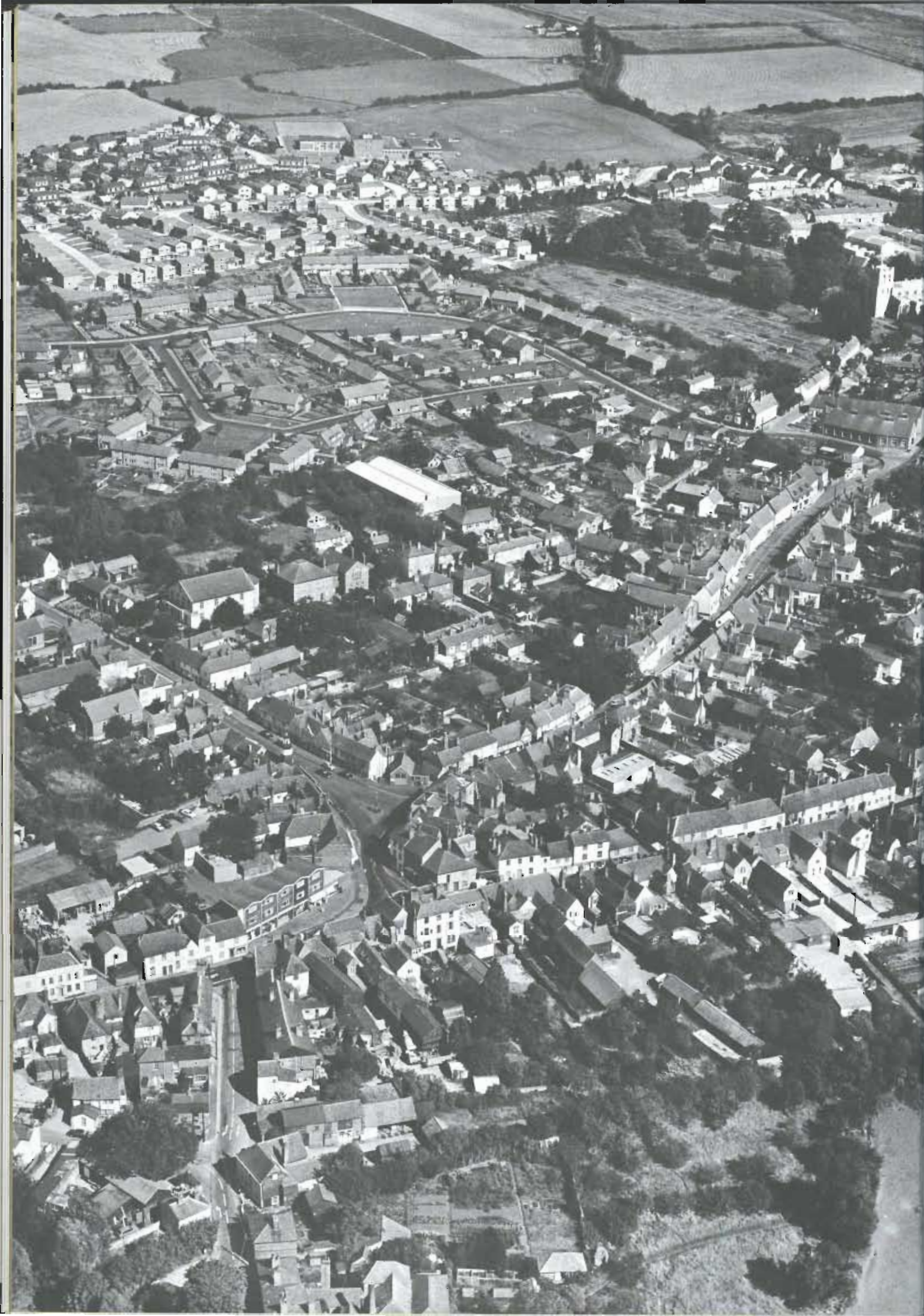

Fig.1.0a, left, Coggeshall, Essex. Photograph by AEROFILMS LTD (copyright reserved)



1.0 b Suburban housing, Feering, Essex.

1.0 c 'Anywhere' type houses, Boreham Village, Essex.



1.0 d Rear gardens of housing, Braintree, Essex.

1.0 e Rear access housing, Boreham Village, Essex.



The existing County Development Plan is to be replaced by a County Structure Plan.

Within the broad strategic framework of this structure plan, more detailed local plans will be proposed. These, in accordance with the Department of the Environment's Development Plans Manual "... will give more precise information to developers by allocating sites for particular purposes, by defining the areas to which particular development control policies will apply, and by explaining those policies in terms of standards and other criteria". These "Local plans provide an opportunity for a full exposition of development control policies, including standards. They will define the broadly-phrased development control policies in the structure plan by relating them to specific areas, by presenting them in more precise terms and by highlighting any local variations."

Local plans will allow the physical integration of compatible land uses which are at present considered as separate entities. For example, the combined open space provision of schools and housing can be used to produce large scale urban parks. These can not only provide a dramatic spatial contrast to the tightly knit fabric of urban development, but also enable higher net residential densities to be achieved—without resort to tall blocks—by the multi-use of open space provisions.

It will be the job of the local plan to determine the mix of house types necessary to an area on the basis of social, physical and visual considerations.

Such plans, by determining the position of schools, shops, public open space and other local facilities, will set the immediate planning framework for housing area design. A good housing layout will not only need to provide safe and convenient access to these facilities, but also ensure that such routes are visually attractive for both the driver and the pedestrian.

At this scale the urban design aspects of the planning process will be more strongly emphasised, though the intention is that local plans should not be used primarily as a negative control mechanism, but as a positive performance brief for developers.

The aim is to provide both physical and visual performance standards, not to foster stereo-type solutions or, alternatively, rigid design control. If a scheme satisfies the criteria—albeit in a different way—then it will be expected to receive favourable consideration.

With all local plans and estate development, it is important that the character and identity of a place—its *genius loci*—is respected and improved upon where necessary. The density and type of development proposed should acknowledge the existing quality and appearance of an area.

In this latter respect, 'Design Briefs' should continue to be produced for important sites—especially those affecting the Conservation Areas of towns and villages.

This publication—Policy and Practice Notes—is intended to supplement the urban design content of local plans, and so complete the three-dimensional framework for housing area development.

In a heavily urbanised county like Essex, it is essential that open countryside should remain near at hand for people to enjoy. This aim can only be achieved if careful land use planning is linked with a sensible policy for housing densities.

The Development Plan Written Statement recommends an *average* net density of 13 to 15 houses to the acre. At this 'land saving' density, comfortable family housing with decent sized gardens can be provided.

In the past, most speculative developers have attempted to meet these densities, but due to a limited and inflexible range of layout principles and house types, they have fallen short. Where developers have been allowed to compress their stereotype suburban layouts and increase density, this has usually been achieved by a reduction in the size of *back* gardens and a further reduction in amenity.

The Department of Environment's Planning Bulletin No. 2 on Residential Areas stresses, that "... The need for more economical use of land does not mean wholesale increases at all levels of density. The need for, and the advantage to be gained from increased density are greatest at the lower end of the density scale." This fact is illustrated by Table 1 below.

Table 1 below is taken from M.H.L.G., Planning Bulletin No. 2, Residential Areas, Higher Densities.

LAND NEEDED FOR HOUSING 1,000 PEOPLE AT VARIOUS DENSITIES.

Table 1

GROSS POPULATION DENSITY P.P.A.	NET POPULATION DENSITY P.P.A.	HOUSING LAND (ACRES)	TOTAL LAND REQUIREMENTS* (ACRES)	LAND SAVING AS DENSITY INCREASES (ACRES)
20	24	42	50	
30	40	25	33	17
40	59	17	25	8
50	83	12	20	5
60	115	8.6	16.6	3.4
70	159	6.3	14.3	2.3
80	222	4.5	12.5	1.8

The figures are calculated on the basis that 1,000 people are to be housed and provided with four acres for open space and four acres for primary schools, local roads, shops, etc.

Table 1 above, shows the relationship between land needs at steadily increasing gross and net densities.* It demonstrates that total land savings diminish at the higher densities. The amount of land needed for open space, schools, etc., depends on the number of people living in the area and not on the amount of land taken up by their homes. Therefore, as densities increase these other requirements bulk larger and larger in the total land needed and the benefit from increased housing densities becomes less and less.

On the other hand, it is equally clear that at the other end of the scale very substantial savings in land are made possible by quite moderate increases in density. By raising the net density from twenty-four persons per acre to forty persons per acre—that is, roughly from eight houses to thirteen—it is possible to save 17 acres of land per thousand population; enough land to house another 500 people at the same density and with the same proportion of open space, etc.

* assumes 8 acres per 1,000 people for other land uses.

Given the fact that most families want to live in traditional housing—that is dwellings up to three storeys in height, with a garden—there are two obvious starting points for increased densities:

1. The omission of all *useless* space on the public side of housing development.
 2. The reduction of the ground cover of individual buildings—by the increased use of two and three-storey house types.
- With efficient layout planning and good house design, this approach can result in the following improvements:
- (a) marginal—but significant—*land saving* increases in density; with the resulting potential of land and services costs per dwelling being reduced;
 - (b) more *useful* public space being provided;
 - (c) larger *back* gardens.

The design guide practice notes demonstrate in Section 4.0 how the proposed range of average densities can be met, with an improvement in the general amenity of housing areas.



2.0

PHYSICAL CRITERIA

Until the adoption of the new policy, county planning standards had been primarily concerned with:

- (1) the problems of accessibility;
- (2) achieving a physically satisfactory environment for people when they are *within*
 - (a) the house envelope, and
 - (b) the curtilage of their own dwelling.

It is these latter 'inside out' standards which have proved to be ineffective; primarily in relation to levels of privacy and back garden areas. These defects arise because the standards are multi-purpose. For example, they attempt to embrace the needs of daylighting, sunlighting, privacy and a minimum garden size in one simple 'rule of thumb' measurement—the old 80 ft. minimum back to back distance between dwellings.

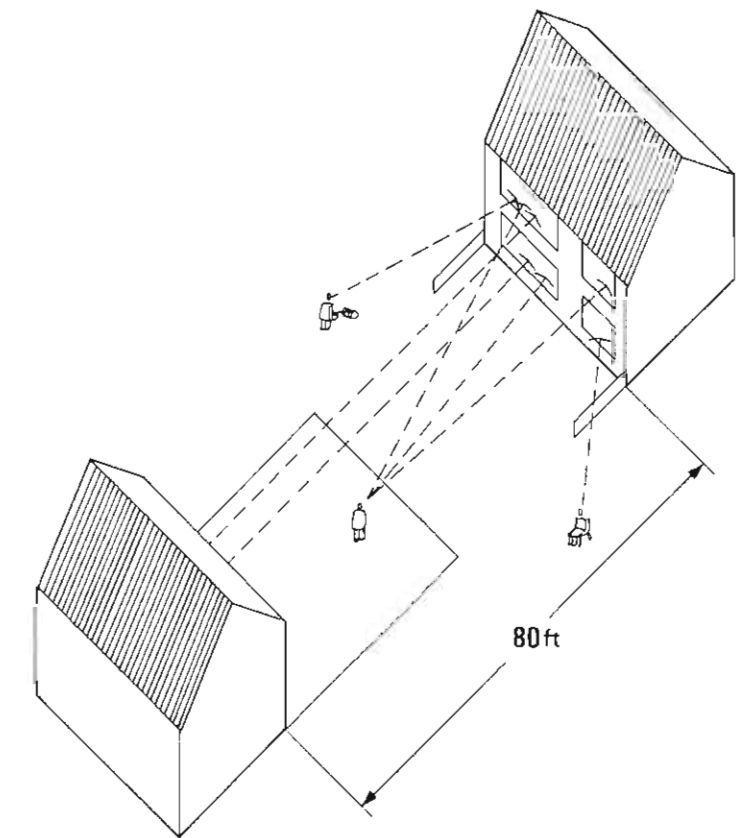

2.0 a

Fig. 2.0a illustrates how the present trend for 'picture windows' on the rear elevation effectively destroys first floor level privacy (at the old 80 ft. back to back standard). On narrow fronted dwellings, side overlooking, from and into neighbouring gardens, also results.

- COLOUR PLATES
- above Infill housing scheme at Saffron Walden for J. Brown, Saffron Walden. R. Halsey, Designer.
 - below Spine footpath. Noak Bridge, Basildon. Department of Architecture, Basildon Development Corporation.

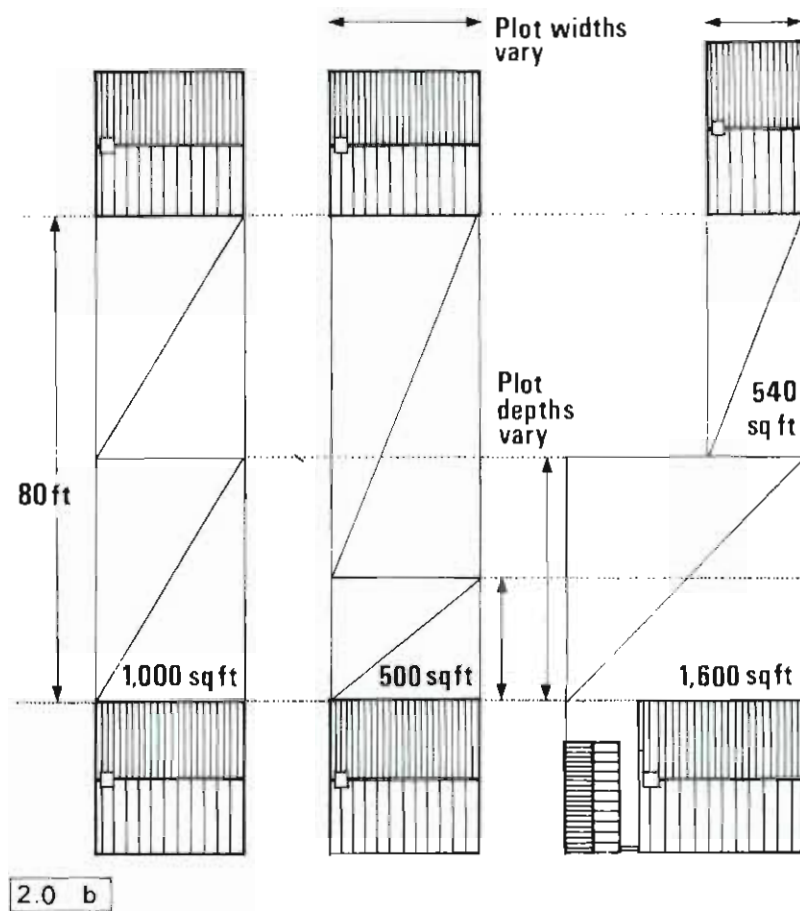

Fig. 2.0b shows how the old standard fails to ensure a minimum garden area, as both plot width and depth can vary.

If we accept that minimum standards are necessary to ensure decent living conditions, then one objective must be to produce such standards in a manner which allows the designer a high degree of flexibility. Therefore, wherever possible, 'performance criteria' have been introduced as an alternative to the multi-purpose rule of thumb dimensions.

2.1 The House Envelope

2.11 Internal Space Standards

New houses are built to last at least sixty years. During this time, higher incomes and changing life styles are likely to lead to families needing more space in the home. It is therefore important that new houses do not become obsolete, due to their size or plan form, sooner than their constructional life dictates. The policy therefore is as follows:

Internal Space Standards

New housing should normally be designed to at least the minimum 'Parker Morris' space standards, as prescribed in the report 'Homes for Today and Tomorrow'.

TABLES OF RECOMMENDED STANDARDS RELATING TO FLOOR SPACE.****(Parker Morris)

	A home to be built in the future for occupation by:					
	6 people	5 people	4 people	3 people	2 people	1 people
	should be designed with a net floor area of at least:					
3-storey house*	97.548 1050	93.800 1010	-	-	-	-
2-storey centre terrace	-	84.541 910	74.322 800	-	-	-
2-storey semi or end	91.974 990	-	-	-	-	-
Maisonette	-	81.755 880	71.535 770	-	-	-
Flat	86.400 930	79.000 850	**69.700 750	56.670 610	44.590 480	29.730 320
Single storey house	83.610 900	75.250 810	66.890 720	-	-	-
						square metres square feet

* These figures will require modification if a garage is built in.
** 66.890sq.m (720sq.ft.) if balcony access.

Table 3

	General storage as follows:					
	6 people	5 people	4 people	3 people	2 people	1 people
Houses***	4.645 50	4.645 50	4.645 50	4.180 45	3.716 40	2.787 30
Flats and Maisonettes Inside the dwelling	1.394 15	1.394 15	1.394 15	0.415 12	0.929 10	0.743 8
Outside the dwelling	1.858 20	1.858 20	1.858 20	1.858 20	1.858 20	1.858 20
						square metres square feet

*** Some of this may be on an upper floor; but at least 2.323sq.m (25sq.ft.) should be at ground level. Dwelling types not included in the above table should use space standards similarly appropriate to their occupancy.

**** The provisions of Circular No 36/67 (MOHLG) 'Housing Standards, Costs and Subsidies', - or subsequent D.of E.circulars- should take preference in relation to local authority housebuilding standards.

At present there is some demand for homes smaller than those meeting 'Parker Morris' Standards. However, in order to avoid an increasing stock of potentially sub-standard dwellings, any sub 'Parker Morris' houses should possess, by their plan form and section, a facility for extension without significantly reducing (a) the amenity of the existing house interior (b) the prospect and amenity of neighbouring property.

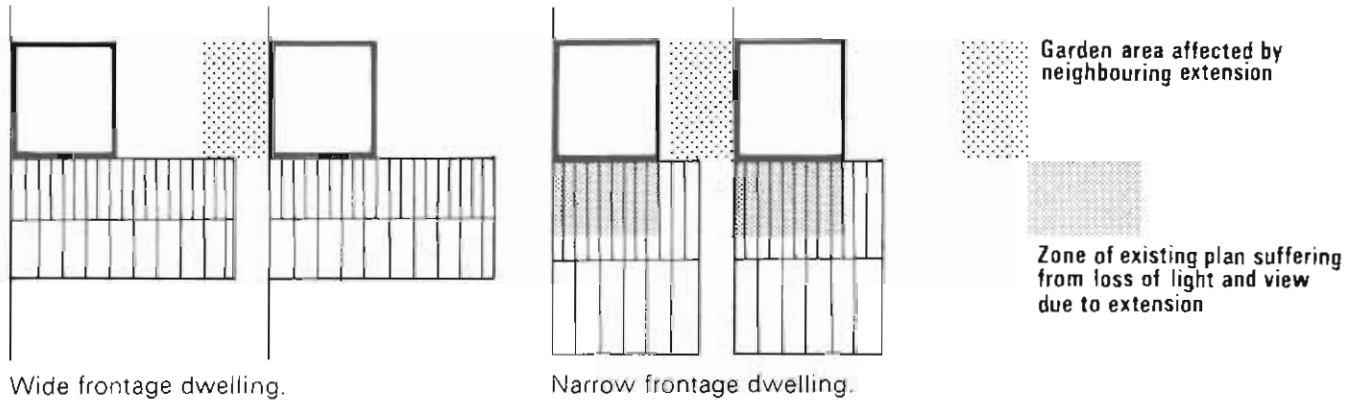

Wide frontage dwelling.

Narrow frontage dwelling.

2.12 a

Fig. 2.12a shows how the wide frontage shallow unit allows easy extension while with a narrow fronted deep plan unit, the interior and neighbouring amenity suffers.

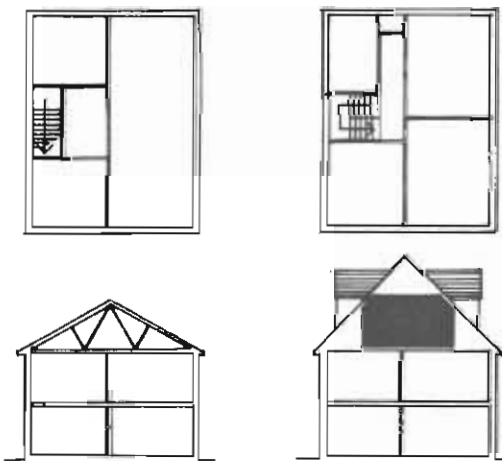

2.12 b Roof extensions.

Fig. 2.12b demonstrates how the straight flight of stairs and low-pitched roof with trussed rafters, does not allow for extension. With a suitable stair design, steep-pitched roof and trussed purlins, future usable space is created.

2.21 c Side extension.

Extended accommodation can also be obtained by building over the garage or above the casual parking area. Fig. 2.12c.

The policy therefore is as follows:

Extendable Houses

Where homes are proposed smaller than the recommended space standards would provide, then a satisfactory means of extending the property up to the required standard will need to be indicated on the initial planning application.

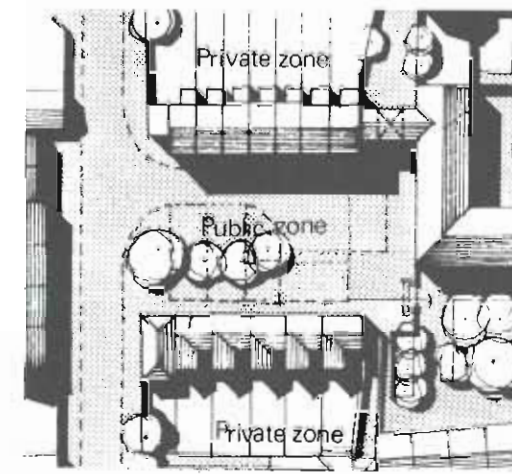

2.13 a Public and private zones.

The internal privacy of the house is affected by two zones of external activity. These are (1) the 'public', and (2) the 'private' zones. Fig. 2.13a.

(1) The 'public zone' as its name implies is the street or public footpath side of the dwelling. Normally visitors, deliveries and passers-by use this space, with the result that rooms with windows facing it are threatened with a potential loss of privacy. Traditionally most housing provided a reasonable degree of privacy from the 'public zone'. Houses were either set close to the footpath, or set well back with a wall, hedge or tree-screen between the footpath and the dwelling. The houses set forward, combined with their small window openings, gave a narrow field of vision to passers-by trying to look in. Fig. 2.13b. Fig. 2.13c.

In fact the field was so narrow that a person wishing to get a good look inside would have to stop, a thing he would be unlikely to do for fear of appearing inquisitive.

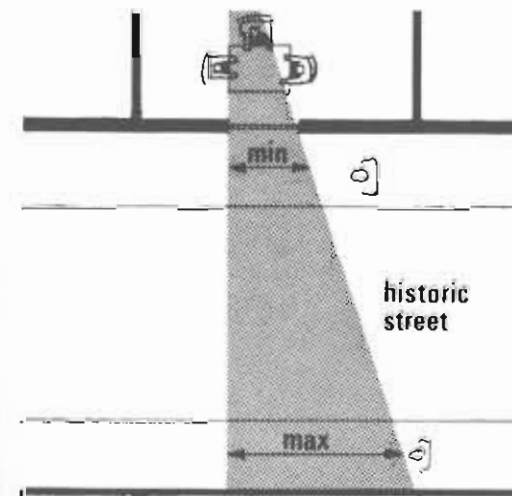

2.13 b The narrow field of vision of the historic street.

The restricted field of vision presented by small windows and set forward buildings.

2.13 c

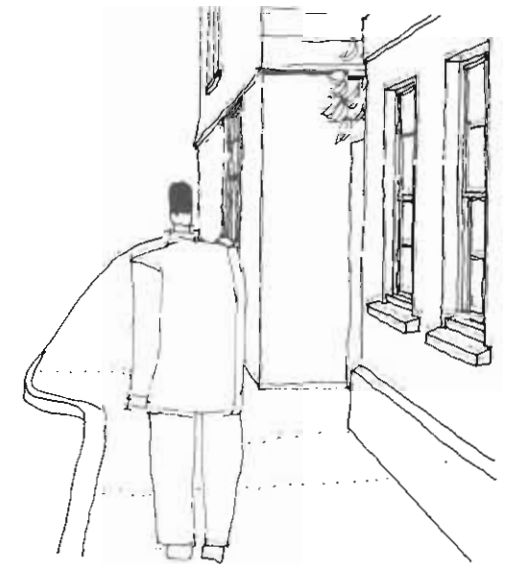

Buildings that were set back had the walls or planting to provide a physical barrier to people looking in.

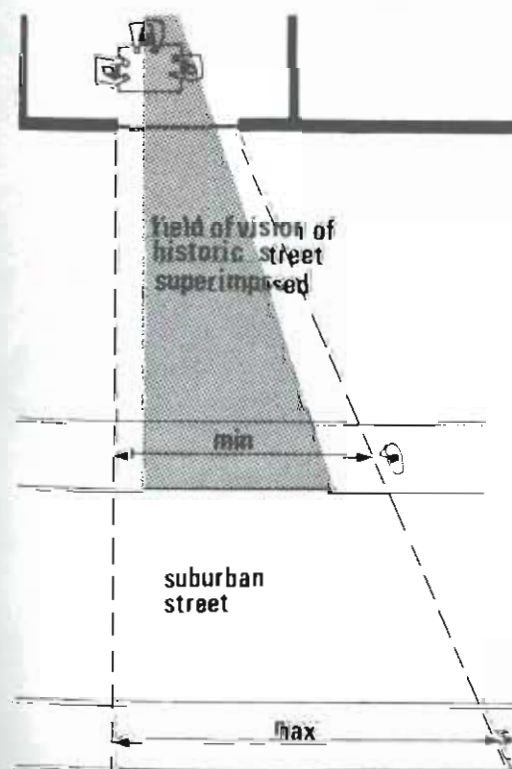

2.13 d The wider field of vision of the 'set back' suburban street.

Recent housing has less privacy than either of these traditional systems. Setting back houses from the footpath, with 'open plan' frontages and larger windows, does not provide privacy either by a restricted field of vision or by a physical barrier. Figs. 2.13d. and e.

Privacy lost through set-back houses giving a wider field of vision.

2.13 e

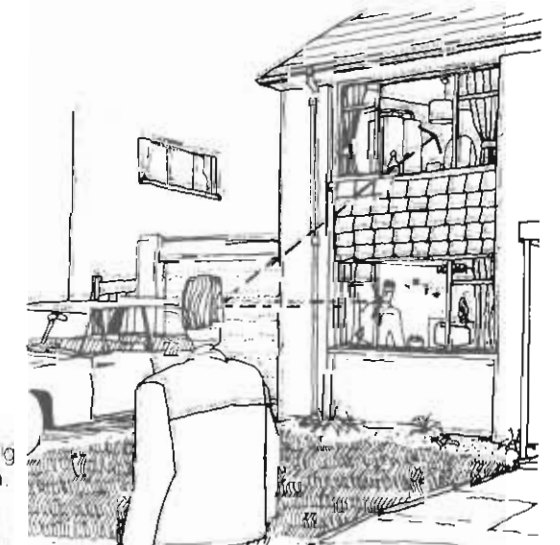

Larger windows, by letting in more daylight, make room interiors more visible from outside—cross lit rooms emphasise this by silhouetting figures—further reducing privacy levels. These uncomfortably low privacy levels need to be overcome by the layout and design of dwellings, otherwise occupiers may be forced to use net curtains to regain adequate privacy. Whilst the net curtain solution may be regarded as satisfactory for most windows, it should be possible to enjoy an uncurtained view out of the main sitting area, without loss of privacy. The policy therefore is as follows:

Internal Privacy

On the 'public zone' side of the dwelling, a reasonable degree of internal privacy shall be achieved for living rooms.

To meet this policy requirement, where ground floor living rooms have windows only on the public side of the dwelling, it is suggested that large windows are screened from the public footpath by above eye-level walls, structures or landscaping set at an adequate distance from the windows. Alternatively, windows should be of restricted size or special design to avoid loss of privacy.

(2) The 'private zone' is taken to mean the back garden area of estate houses. Ideally the living rooms on this side of the house should have the option of being completely private—that is, not overlooked from neighbouring houses or their gardens. This ideal is difficult to achieve in all cases; nevertheless, the design should offer as much privacy as possible.

Traditionally privacy was achieved in two ways. Firstly by *remoteness*—this is where the houses are set well apart among trees, as in Victorian arcadian developments. Secondly by *design*—here, as in the historic village, high garden walls, projecting wings and out-buildings provide privacy for back rooms. Fig. 2.13 f and g

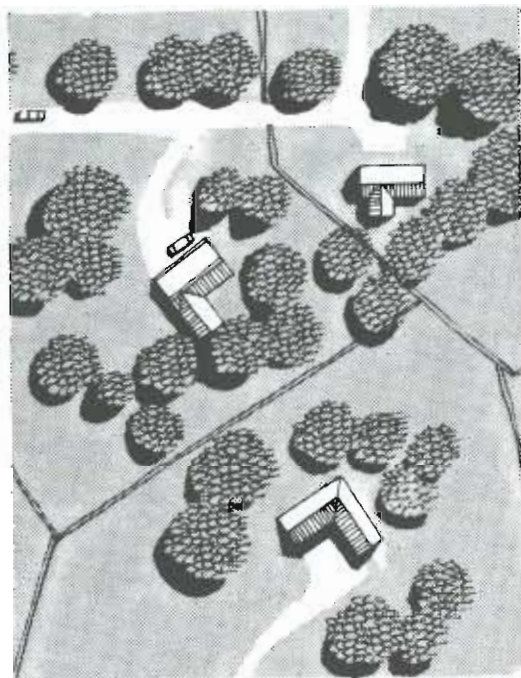

2.13 f Traditional arcadian privacy achieved by remoteness.



2.13 g Traditional urban privacy achieved by 'design'

Privacy from overlooking can therefore be achieved by:
 (a) REMOTENESS—This is usually a degree of privacy—for design purposes, an 'eye to eye' distance of 35m (115 ft.), will give an adequate degree of privacy by remoteness.

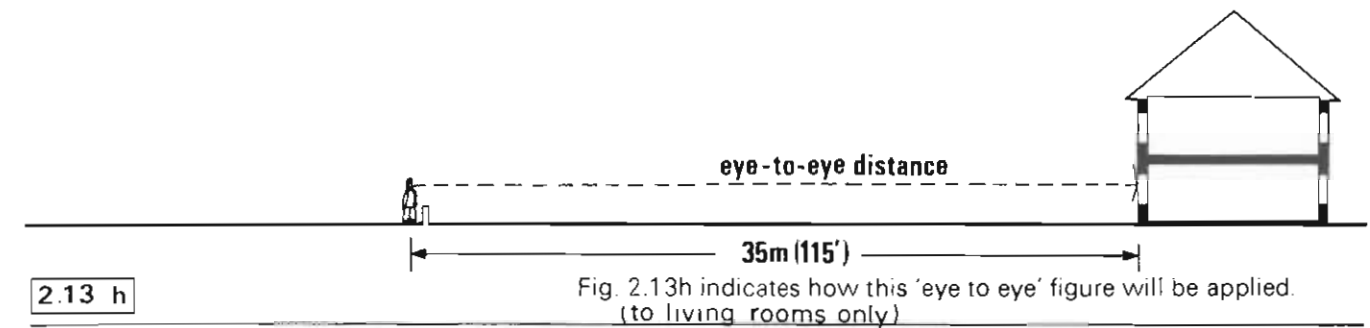

(b) DESIGN—Here complete privacy is possible even at minimal distances.

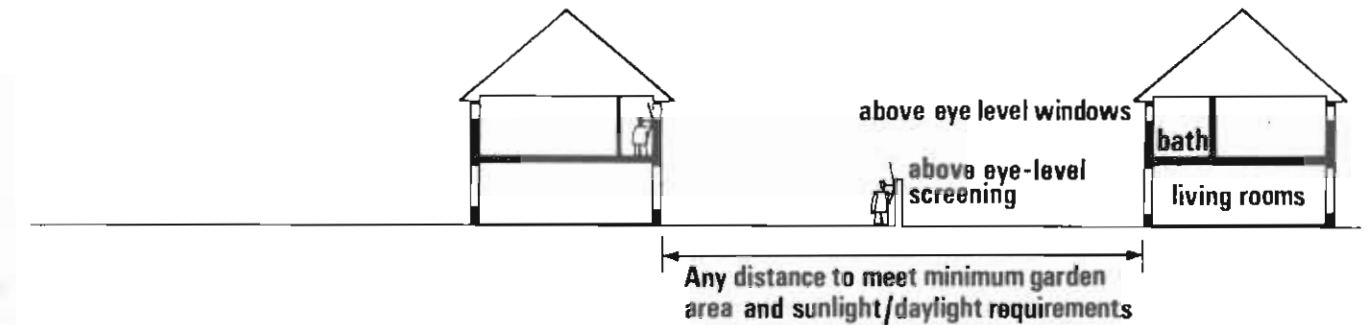
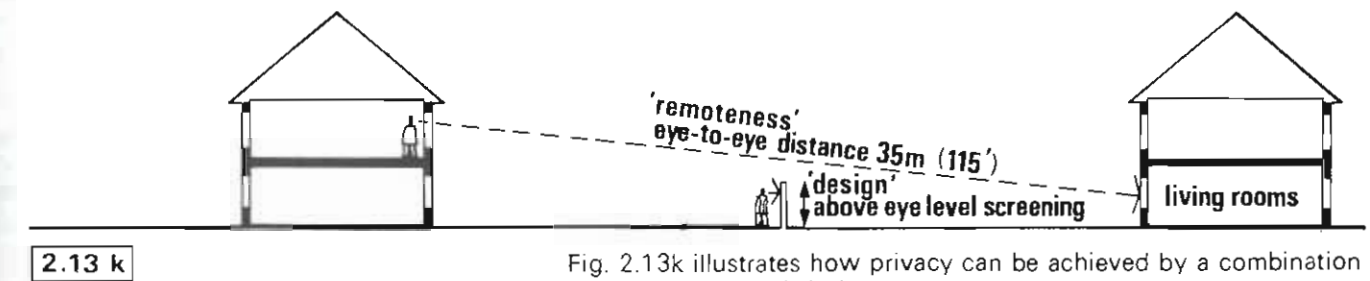

Fig. 2.13j illustrates how this can be achieved.



This latter solution will be usual where narrow-fronted house types are used, as these plans need to be deep and normally require dual aspect on all floors. It should be noted that gardens at least 18.300m (60 ft.) long will be necessary in any case if plans have less than a 5.500m (18 ft.) frontage, to achieve the 100 sq. m. (1080 sq. ft.) garden.

The policy therefore is as follows:

Internal Privacy

On the 'private zone' side of the dwelling, a high degree of internal privacy shall be provided for living rooms. If a living room is overlooked from an opposing dwelling or curtilage, the minimum 'eye to eye' distance shall be 35m.

NOTE: The question of overlooking from unscreened *side* curtilages is dealt with under section 2.21.

In housing areas intrusive noise can be a source of lasting irritation and friction between neighbours. The hobby of one person can be the curse of another's life. The potential for such conflicts increases as dwellings are packed closer together; in some flats families have neighbours on four or more sides.

Semi-detached, terrace or flat dwellings all have the problem of *structure-borne* noise. This particular deficiency in the terrace house has given rise to its lack of wider public acceptance. It is therefore strongly recommended that party walls should be constructed to provide a higher sound insulation level than that required by the present regulations. This is necessary if architects and developers are to make such (higher density) homes an attractive alternative to the semi-detached.

The other source of noise which affects dwellings is *air-borne*. In terms of sound insulation against this kind of noise, openings—that is windows and doors—are the weak element in the house facade.

Air-borne noise, usually from traffic, needs to be kept at an acceptable level within the home. The ideal solution is to limit noise at its source, by employing quieter vehicles, or planning the estate layout to reduce to a minimum the number of vehicle movements past certain types of house. However, where high external noise levels cannot be avoided, then this noise must be reduced to an acceptable level inside the dwelling by the use of sound insulation.

The policy therefore is as follows:

Sound Insulation

The design and layout of new housing areas should normally be such as to ensure that the immediate external noise environment to any dwelling does not exceed 70dB(A) on the (L10) index. Any new dwelling which is likely to be affected by noise ratings which exceed this figure shall be so designed as to ensure that the internal noise level does not exceed 50dB(A).
(*D. of E. Planning Bulletin 26)

NOTE: Where new housing is to be built within a prescribed *airport noise zone*, a detailed specification of criteria necessary to meet the required standard of sound insulation has been set down and is available on request from the County Planner.

The Department of the Environment's manual 'Sunlight and Daylight' describes criteria for the control of development and the design of buildings in relation to these factors.

This document replaces Planning Bulletin No. 5 which formerly dealt with this subject. The new manual is advisory.

The main changes from past practice are in the method of checking block spacing. These can be summarised as follows:

(i) More emphasis is laid on sunlight in housing layouts. For southerly faces of residential buildings, the daylight criterion is abolished and replaced by a sunlight criterion. The new sunlight criterion *does not*, however, involve such wide spacings of buildings as the old one.

(ii) The daylight criteria are modified. The new criterion for housing *does not involve such wide spacing as the old one*.

In fact, in proposed housing layouts, block spacing that satisfies the new requirements of sunlight and daylight may be too near to give adequate privacy. Therefore, obtaining the required privacy level in the 'public' and 'private zones' will usually remain a *more* critical factor for block spacing.

Where it is necessary, in borderline cases, to assess the likely levels of daylight and sunlight in a room, the planning authority will take into account the following factors:

- (1) Room size and proportions
- (2) Window size and position
- (3) Height and distance of any external obstructions

To sum up, the provision for good sunlight and daylight in buildings is important but not necessarily more important than other require-

ments, such as privacy, good views out, the economic use of urban land and a visually attractive environment.

Sunlight and Daylight

The design and layout of buildings shall ensure adequate daylighting levels within rooms and that an acceptable amount of sunlight can reach into each dwelling curtilage in accordance with standards recommended by the D. of E.

In the Department of the Environment research study 'Housing: The home in its setting' it is stated that "...the greatest contribution to adults leisure activities, within the housing area, is a *private garden*".

In effect, this means a garden not overlooked from other gardens and dwellings; Fig. 2.21a

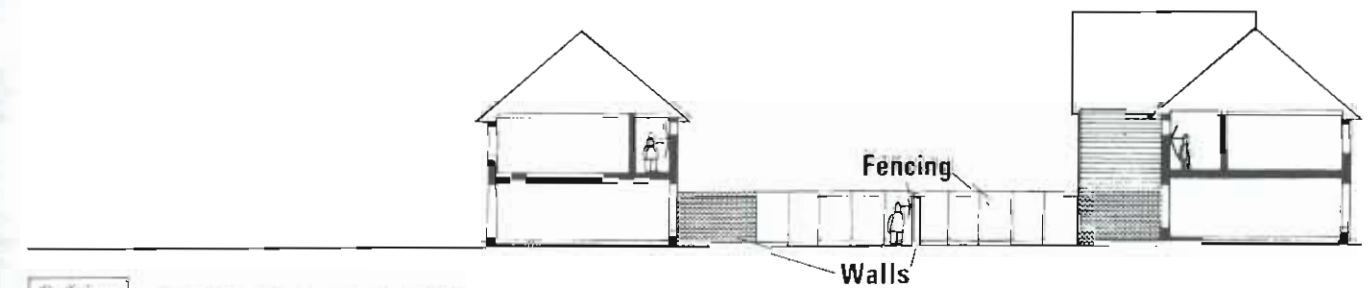

2.21 a Garden privacy by design

Overlooking from surrounding gardens and ground floor windows can be effectively prevented by above eye-level screens. Overlooking from upper floor windows, with conventional cill levels, will still occur unless the view from them is very oblique, they are sufficiently remote, or screened by buildings or trees. Fig. 2.21b

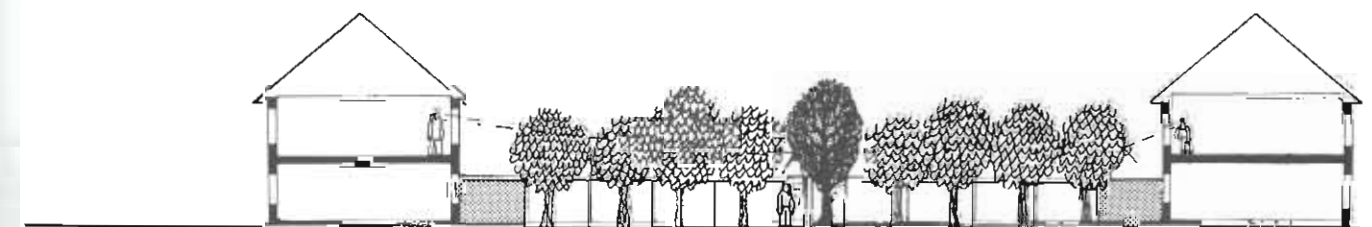

2.21 b

Screen planting effectively blocks first floor overlooking
Private zone

Designs which give residents the option of a completely private garden will be encouraged. However, the policy provision is less stringent, requiring an area of each garden to be designed so that it is possible to sit outdoors and not be visible from the main sources of overlooking, namely surrounding living rooms and outdoor sitting areas. To be useful, the private area will normally need to extend for at least 3m (10 ft.) and be permanently screened by above eye-level walls or structures, where the eye to eye distance is less than 35m. The policy therefore is as follows:

'Private Zone'

New houses shall have an outdoor sitting area not overlooked by adjacent or opposing outdoor sitting areas or living rooms; this requirement to be achieved by the design and layout of above eye-level permanent structures and walls.

It is likely that most householders will choose to complete the enclosure of the boundary round their garden by inserting additional hedging or screens. Some families may wish to consolidate their joint private garden areas and have a wider view. This will be their option. Fig. 2.21c.

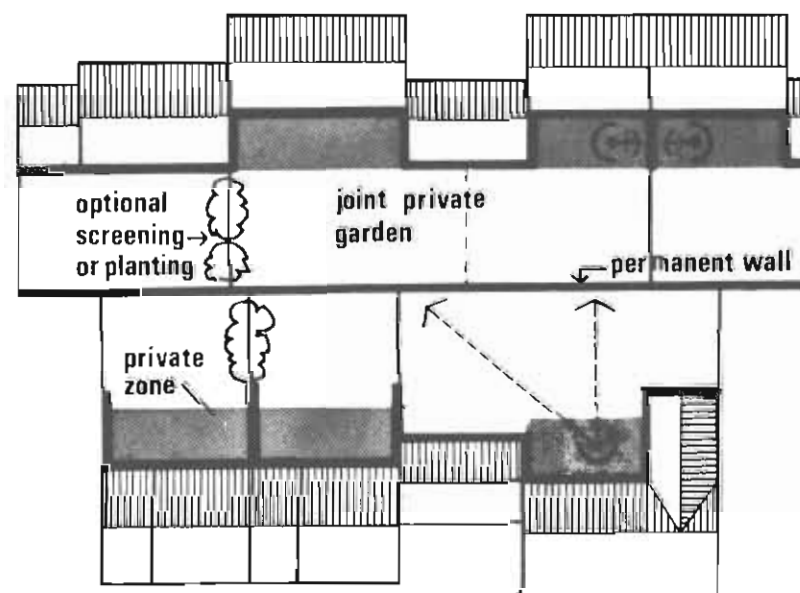

2.21 c 'Private zone' options for privacy

Such arrangements are likely to be the exception for, as 'Housing: The home in its setting' states "... strained relations between neighbours are far more apparent on estates planned without dividing fences". For this and other good reasons most families prefer a decent sized and relatively private garden.

2.22

Minimum Garden Area

It has already been established why the old multi-purpose standard failed to ensure a minimum back garden area (Fig. 2.0b). Some of these gardens on estates have been made so small that they literally offer the prospect of small children playing under dripping nappies. On the other hand, a minimum garden area based solely on the aggregated physical requirements of family activities could produce a space which, if enclosed for privacy, might be considered as being visually oppressive and cell-like. A private garden must therefore afford the possibility of giving visual delight—to do this, an area and shape sufficient to receive some sunshine and encourage plant growth is required.

The policy therefore is as follows:

Minimum Garden Area

Houses when built, shall have a minimum 'private zone' garden area of 100 sq.m. (1,080 sq. ft.).

Exceptions to the policy will be

- (i) single-storey patio housing—where a walled patio area of 50 sq.m. (540 sq. ft.) minimum will be required, a substantial proportion of which shall be paved.*
- (ii) dwellings contained within a substantial area of well landscaped and properly maintained communal open space.**

* The reason for this lesser standard is that the patio by being hard surfaced is *dual* purpose for both physical and visual requirements, and as it serves a single-storey building, complete privacy and good sunlighting can be obtained.

** This provision is designed to cater for higher density local authority schemes. Though the principle will also apply to the private sector when complying to the policy provisions.

Minimum garden areas give the designer more flexibility for providing differing shapes than was possible with the old back to back standard, while still allowing land saving densities to be achieved.

2.23

Sitting out areas for flats

In the case of flats, the following standards are suggested:

- either (i) minimum balcony area 5 sq. m (54 sq. ft.)—with the ground floor flat or maisonette having a minimum patio garden area of 50 sq. m (540 sq. ft.).
- or (ii) alternatively, communal resident gardens can be provided, the minimum area of which should be calculated on the basis of 25 sq.m (270 sq. ft.) per flat.

In practice, a combination of these standards is likely to be necessary. Case Study 4.4 illustrates this point.

2.3

Services

2.31

General Services

These services can be classified as:-
water supply; surface water and sewage disposal; gas and oil; electricity, telephone and television supply; nameplates and markers.

First, it is essential that all such services are provided in a technically and *visually* satisfactory manner. A compact housing layout will enable this standard of service provision to be made economically.

Supply and disposal services:

These are best carried below the footpath or grass verge in front of each house curtilage—no change is proposed to this established engineering practice.

Attention is drawn to the Ministry of Public Building and Works study groups report—'Co-ordination of Underground Services on Building Sites, (H.M.S.O. 1968). The proposals in this report for common trenching, based on the standard depths and positions for underground services in the footway, recommended in the earlier Civil and Municipal Engineering Institutes Joint Report—should be implemented wherever possible.

However, in new urban layouts the reduction of land area in the public zone will mean that the provision of such services will have to be more carefully considered than they have been in the past.

Due to this, applicants will be requested to:

- (i) indicate schematically on their detailed planning applications the position of all General services;
- (ii) have previously consulted with the appropriate statutory undertakers and local highway authority so as to ensure that the proposed service positions are acceptable to all these bodies.

Telephone Supply:

The G.P.O. publication—'Provision of Telephone Facilities on New Housing Estates'—is commended to developers and architects. It will be noted from this that the Post Office will accept a contribution 'in kind' or cash towards providing an underground service. The latter alternative is, at present, on the basis of £10.00 for every dwelling served—a small price to pay for the added amenity value this gives to an estate.

T.V. Aerial Systems:

The current practice by which every householder has to erect a private T.V. aerial system is most unsatisfactory. Such fittings are usually silhouetted against the skyline and, as a result, are unduly intrusive in the street scene.

It is, therefore, recommended that new dwellings should make provision for incorporating either:

- (a) a loft or below rear ridge line private T.V. aerial system, or
- (b) a communal T.V. supply system.

Electricity Supply

Meter Cupboards

Consideration should be given to fixing meters in such a position that they can be read from outside the dwelling.

Sub-stations

It is considered that sub-station and transformer installations should be totally enclosed in a suitably designed structure.

This will help to overcome any noise to nearby dwellings and give the installation a better appearance when seen from above.

Central Oil Storage Tanks:

It is important that such installations are served from the appropriate type of road. (Related to vehicle size and turning space provision—See Section 2.322 'Vehicular Movement')

Nameplates and Markers:

These are best fixed to walls and buildings where they can be clearly seen: free-standing street furniture tends to clutter spaces and therefore should be kept to a minimum.

The policy therefore is as follows:

General Services to dwellings

All services to dwellings shall be provided in a technically and visually satisfactory manner.

2.321

Pedestrian Movement

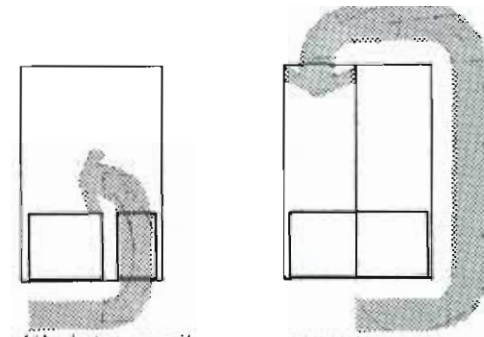

(1) inter-curtilage movement.

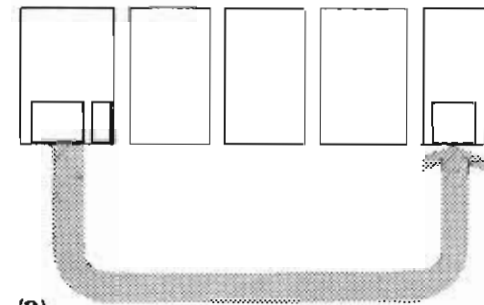

(2)

Within new housing areas, pedestrian movement should be:

- (i) convenient,
- (ii) safe,
- (iii) pleasant.

With these aims in mind it is important to define the broad categories of pedestrian movement.

Fig. 2.321a illustrates the categories of local pedestrian movement within residential areas. These are:

- (1) household movement—e.g. bringing the lawn mower through to the back garden.
- (2) dwelling to immediate vicinity movement—e.g. calling in on a neighbour, or small children gathering to play nearby.
- (3) dwelling to local facilities movement—e.g. taking the children to school, going to the local shops or the bus stop.

All pedestrian movement can be fitted into a hierarchy of convenience related to the type of journey. For example, category (2) calling in on a near neighbour is usually a leisurely activity—the footpath in this situation can reflect this function by a less direct alignment.

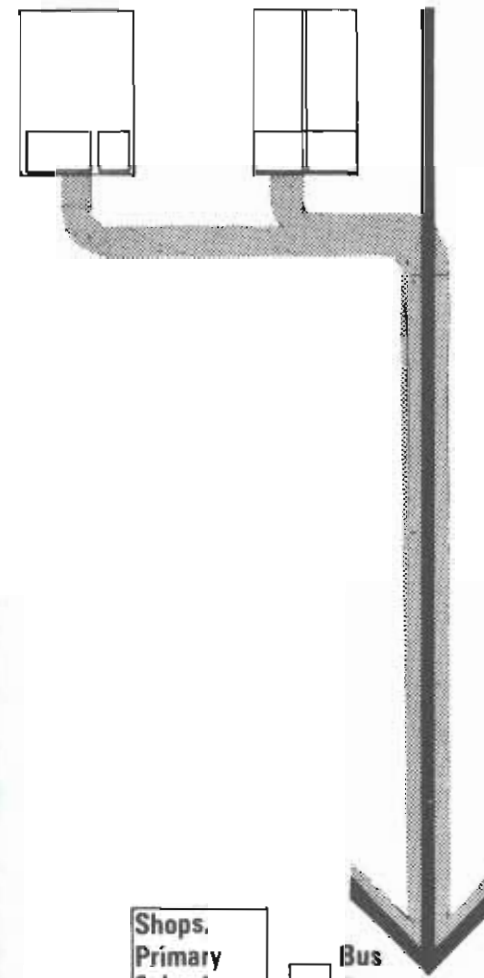

(3)

Dwelling to immediate vicinity.

Dwelling to Local Facility.

2.321a Pedestrian Movement

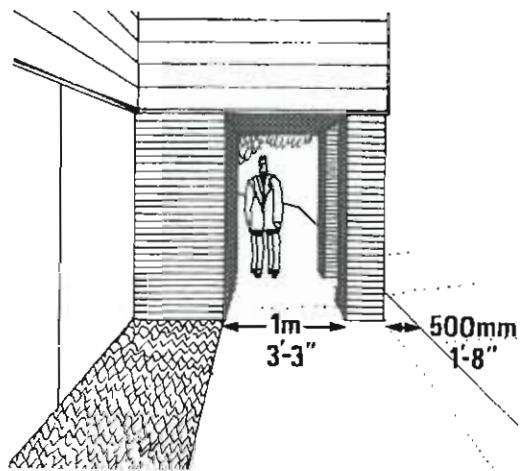
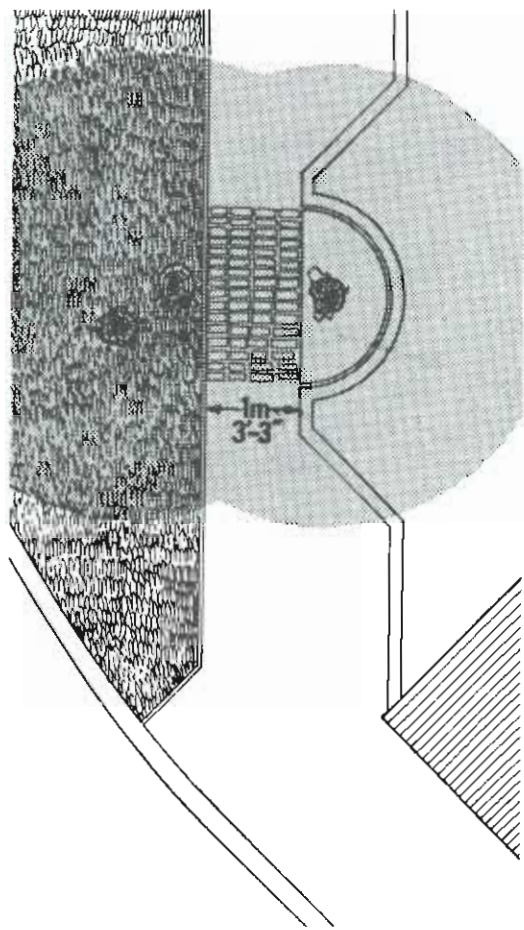

2.321 b Access footpaths narrowed to form a courtesy section.

The width of these 'local access' footpaths should normally be sufficient for two prams or two pedestrians to pass. However, it is not too onerous in this situation to have 'courtesy sections' where the footpath can be narrowed down to a single pedestrian width of 1m (3 ft. 3in.). These should normally not exceed 8.0m (26 ft.) in length and be positioned so that pedestrians are not induced to step into the carriageway.

Fig. 2.321b illustrates how this would work in practice by allowing (for example)

- (i) a tree to be retained, or
- (ii) a building to project over the pavement at first floor level, the minimum headroom to the underside of which shall be 2.25m (7ft. 4 in.).

both giving added spatial enclosure to the street scene.

Many 'local access' footpaths will need to run beside carriageways. As such they should be delineated as being physically separate from the carriageway. The normal method of achieving this is the vertical kerb which physically discourages vehicles from parking partially or wholly on footways.

The 'local access' footpaths should be designed to link, wherever possible, into 'pedestrian spine routes'. These wider footpaths must aim to provide

- (i) the most *convenient* route for walking through the estate or to the local facilities in or near the residential area.

The width of these more intensively used 'spine routes' should be about 3m (10 ft.)—sufficient for groups of pedestrians to pass comfortably. When necessary lamp columns and other street furniture should be recessed so as not to obstruct the footpath. Where sharp changes of levels occur, such footpaths will be required to provide ramps—in addition to any steps—for prams and the disabled. These routes will also need to be clearly signed so that visitors can find their way about easily.

- (ii) 'Spine routes' must be especially *safe* for the pedestrian - the best way of achieving this is by segregating them from the motor vehicle. Where the two have to cross, then the opportunity should be taken to stagger the footpath and arrest the pedestrian desire line. At such points sight lines will be necessary. Strategically placed barriers will also help to halt the pedestrian before a road crossing. Barriers will also have the incidental effect of discouraging the short-cut cyclist.

- (iii) In addition to the requirements of convenience and safety, a 'spine route' must be *pleasant*. That is to say, it should be both physically and visually comfortable. It should provide, by the architectural treatment of its edges, a high degree of protection from wind and driving rain. High walling, tree planting, and buildings are the essential components to create such sheltered linear spaces.

The policy therefore is as follows:

Pedestrian Movement

Within new housing areas pedestrian movement shall be made convenient, safe and pleasant, by the provision of carefully positioned and well designed 'pedestrian spine routes' and 'local access footpaths'.

NOTE: the new County Highway standards for footways are set out in Section 2.322.

Footpath Lighting

'Spine routes' and segregated access footpaths - by being solely designed for pedestrian movement - provide the opportunity for imaginative amenity lighting schemes. Wherever possible, covenants should be obtained so that bracket mounted lights can be used in favour of free standing columns, as this helps to keep the pavement area clear of unnecessary obstructions. The lighting of other 'access footpaths' will usually be incidentally achieved from the lamps required for road lighting purposes, though specially provided footpath lighting will need to be used on occasions.

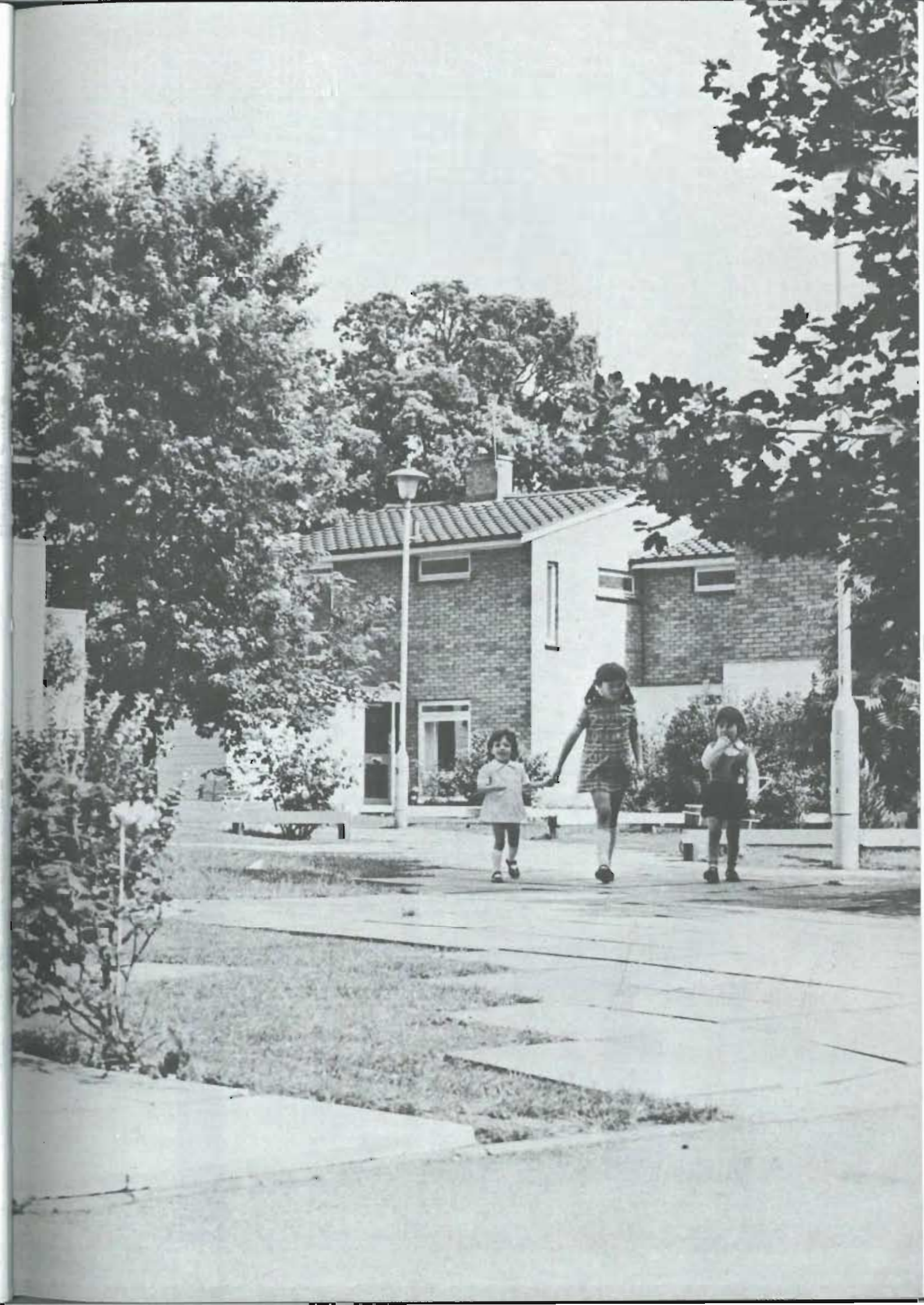

PHOTOGRAPH right Segregated footpath at Melbourne Cedars, Chelmsford.

Within new housing areas through traffic should be discouraged, while local vehicular movement should be:

- (i) convenient,
- (ii) safe,
- (iii) pleasant.

With these aims in mind, a variety of vehicles will need to be catered for such as :-
the bus, large delivery and collection vehicles; the car, motor cycles, cycles.

The proposed hierarchy of vehicle routes

All vehicular movement can be fitted into a hierarchy of routes which relate to differing levels of accessibility.

Fig. 2.322a illustrates the six types of route for housing area traffic circulation.

Each class of route attempts to reflect its different role in the hierarchy by its visual appearance and related physical design standards.

County Highway standards

The new standards are set out in table 4 with related notes 1-20 following. The objective has been to devise standards which meet the above aims while at the same time allowing better densities and *townscape* to be achieved in housing area design.

If applied correctly these standards will produce a 'deemed to satisfy' solution - capable of adoption for the purposes of maintenance.

It is not intended that these standards should be treated as a finite statement; from time to time and as circumstances demand, revisions and supplementary design criteria will be needed.

The latter information will take the form of Aspect papers. In the meantime, alternative proposals for meeting the required highway design criteria, will be considered on their merits. In such cases, the onus is put on the architect or his consultant engineer to prove his own case. The policy therefore is as follows:

Vehicular Movement

Within new housing areas, vehicular movement shall be made convenient, safe and pleasant by the provision of
(i) a road system segregated from through traffic flows;
(ii) a clearly defined hierarchy of routes, with roads differing in size, alignment and standard according to the designed speed and volume of traffic they are intended to carry.

* Notes for guidance in preparing engineering drawings and in specifying materials and construction can be obtained from the County Highways Authority.

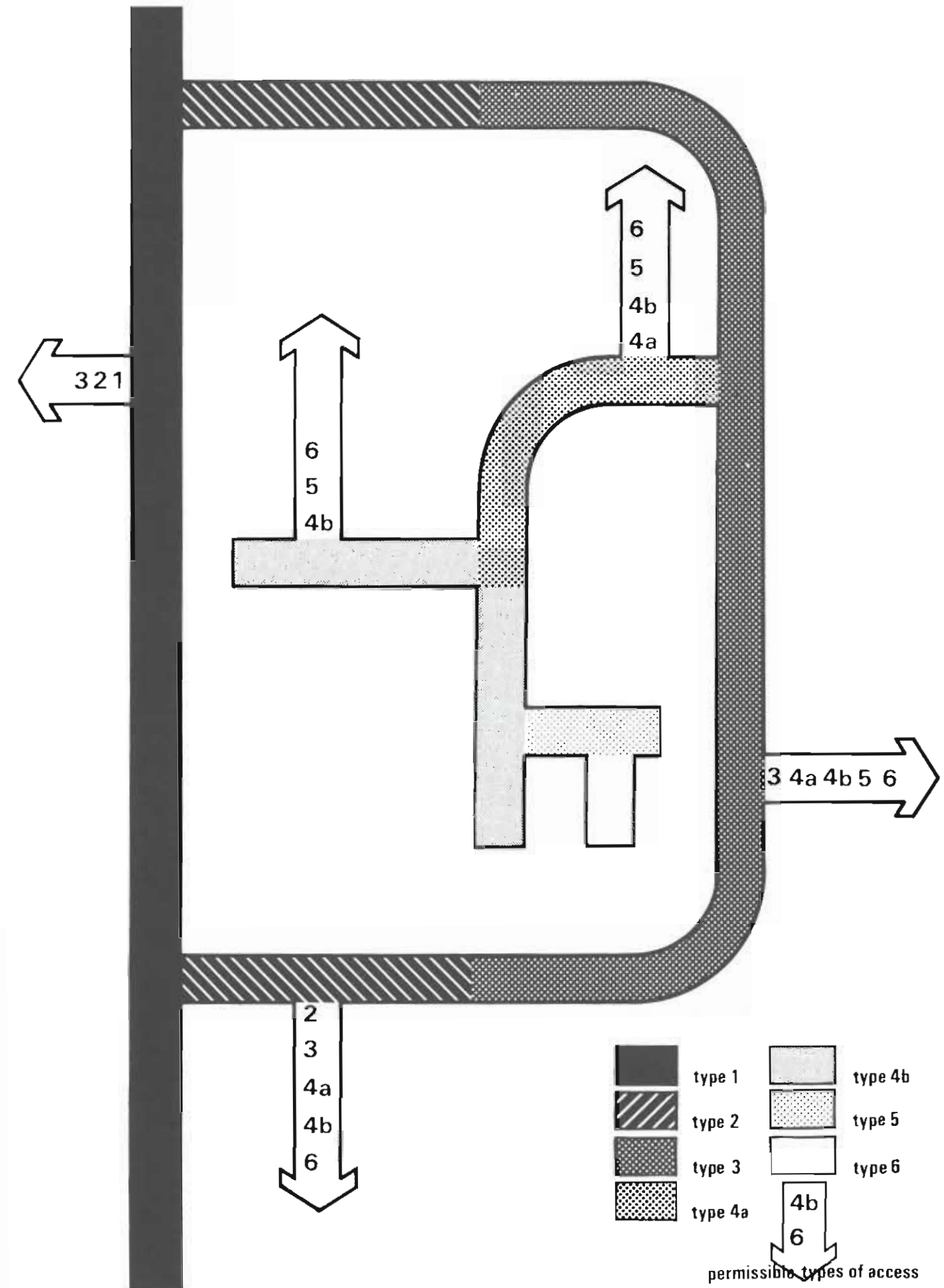

Table 4

*COUNTY HIGHWAY STANDARDS

1a 2

Reference No. of relevant NOTE

TYPE OF ROAD	DESIGN SPEED	MINIMUM WIDTH OF C/WAY	MINIMUM WIDTH OF FOOTWAYS	MINIMUM WIDTH OF VERGES	NORMAL BEND C/L RADIUS	MINIMUM BEND C/L RADIUS	JUNCTIONS MINIMUM SPACING	SIGHT LINES	KERB RADIUS	TURNING BAY SIZE	RESTRICTION TO TYPE OF ROAD FROM WHICH THEY MAY HAVE ACCESS	ACCESS RESTRICTIONS	MAXIMUM ROAD GRADIENT
Type 1 LOCAL DISTRIBUTOR These <i>through</i> roads distribute traffic within environmental areas—they form the link between district distributors and access roads. A local bus route could run along these roads	50 kph (30 mph)	7.300m (24 ft. 0 in.) or 6.750m (22 ft. 2 in.) with bus lay-bys.	Two x 2m (6 ft. 7 in.)	Two x 1.200m (3 ft. 11 in.)	200m (656 ft.)	90m (295 ft.)			Compound 31.500m (103 ft. 3 in.) and 10.500m (34 ft. 5 in.)		Primary distributor District distributor Type 1	No frontage access	5% (1 in 20)
		3			8	8 9	10	11 12	13 14				20
Type 2 MAJOR ACCESS ROAD These <i>through</i> roads give direct access to buildings and land within environmental areas.	30kph (20 mph)	6.750m (22 ft. 2 in.) or 6m (19 ft. 8 in.) widening to 6.75m on bends	Two x 2m (6 ft. 7 in.)	Not normally required	75m (246 ft.)	35m (115 ft.)			Compound 31.500m (103 ft. 3 in.) and 10.500m (34 ft. 5 in.)		Types 1 and 2	Frontage egress from dwellings to be in forward gear only	5% (1 in 20)
		3	4		8a	8a 9	10	11 12	13 14			19a 19b	20
Type 3 INTERMEDIATE ACCESS ROAD These are minor loop roads and culs-de-sac over 300m. (984 ft.) in length serving as access to not more than 400 garages and hardstandings.	30 kph (20 mph)	6m (19 ft. 8 in.) widening to 6.750m (22 ft. 2 in.) on bends.	Two x 2m (6 ft. 7 in.)	"	75m (246 ft.)	35m (115 ft.)			10.500m (34 ft. 5 in.)		Types 1, 2 and 3	Frontage egress from dwellings in reverse gear normally allowed, though dwellings near more heavily trafficked junctions may need to be in forward gear only.	5% (1 in 20)
		3	4		8a	8a 9	10	11 12	13 14	16 18		19a 19b	20
Type 4A MINOR ACCESS ROAD These are minor loop roads and culs-de-sac not exceeding 300m. (984 ft.) in length and serving as access to not more than 200 garages and hardstandings.	15 kph (10 mph)	5.500m (18 ft. 0 in.) widening to 6m (19 ft. 8 in.) on bends.	Two x 2m (6 ft. 7 in.)	"		13.750m (45' 1in)			10.500m (34 ft. 5 in.)		Types 2, 3 and 4A		6% (1 in 16.7)
		3	4a		8a	8a 9	10	11 12	13 14	16 18		19a 19b	20
Type 4B MINOR ACCESS ROAD These are minor loop roads and culs-de-sac not exceeding 100m. (328 ft.) in length and serving as access to not more than 75 garages and hardstandings.	15 kph (10 mph)	5.500m (18 ft. 0 in.) widening to 6m on bends.	Two x 1.750m (5 ft. 9 in.)	"		13.750m (45' 1in)			Compound 18m (59 ft.) and 6m (19 ft. 8 in.)		Types 2, 3, 4A and 4B		6% (1 in 16.7)
		3	4b				10	11 12	13 14 15	16 17 18		19a 19b	20
Type 5 MEWS COURT These are culs-de-sac in medium and high density urban type development not exceeding 36m. (118 ft.) in length and serving as access to not more than 25 garages and hardstandings.	VERY LOW	Combined vehicle/pedestrian area 5.500m (18 ft.) wide between entrance walls				13.750m (45' 1in)			By vehicular crossing of footway: no radius kerb		Types 3, 4A and 4B		7% (1 in 14.3)
		5 6						11 12		16 17			20
Type 6 PRIVATE DRIVE These serve a maximum of three dwellings.	VERY LOW	2.500m(8 ft. 2½ in.)for a single dwelling only; for a shared drive 4.250m(13 ft. 11 in.)for the first 6m(19 ft. 8 in.)from the highway boundary.				6m (19 ft. 8 in.)					Types 2 (with turning facilities), 3, 4A, 4B and 5.		8% (1 in 12.5)
		7						11 12					20

*These standards are superseded. See separate document. Highway Standards 1980.

NOTE 1

DIAGRAM OF MINOR ACCESS LOOP ROADS

Minor access roads of types 4A and 4B may be formed as loops only where 'Y' is at least 50% greater than X, so that no short cuts are to be created. Diagram on left shows method of measuring X and Y.

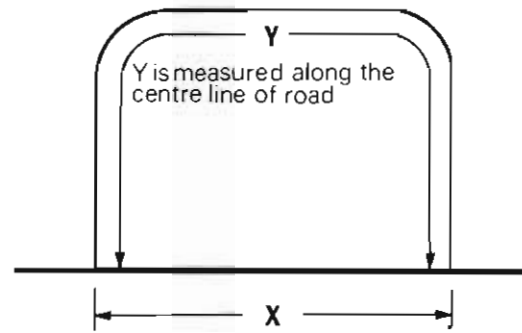

NOTE 1a

DIAGRAM ILLUSTRATING METHOD OF MEASURING EFFECTIVE LENGTH OF CULS-DE-SAC OR THE NUMBER OF HARDSTANDINGS AND GARAGES SERVED; FOR DETERMINATION OF TYPE OF ROAD REQUIRED.

All lengths of road (including mews courts) or garages and hardstandings, which have access from the roads under consideration, shall be aggregated.

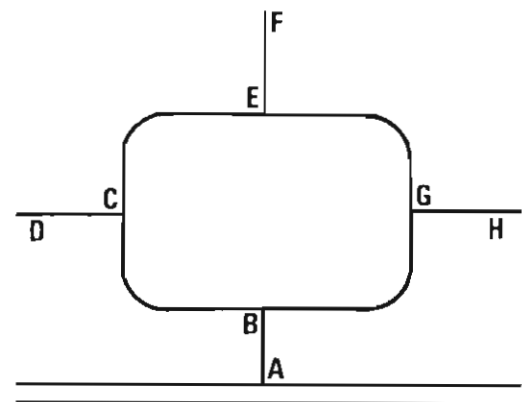

Road under consideration	Effective Length is aggregate of road lengths below No. of hardstandings/garages is aggregate of those served by roads below
AB	AB + BC + CD + CE + EF + EG + GH + GB
BC	BC + CD + CE + EF
BG	BG + GH + GE + EF
CE	CE + EF
GE	GE + EF

NOTE 2

Culs-de-sac must be incapable of extension without demolition of dwellings. Open ended culs-de sac will be required to be of a minimum layout of a type 3 road.

NOTE 3

Vertical clearance of 6m (16ft 4in.) is required over the full width of carriageway plus 0.500m (1ft. 8in.) either side. In the event of a crossfall on the carriageway being greater than 2½% (1 in 40) the 0.500m (1ft. 8 in.) dimension will need to be increased to 0.610m (2ft.) on the low side of the carriageway.

NOTE 4

Increased footway to 3m (9ft. 10in.) width where the density of vehicular crossings is so great that either (i) in any 30m (98ft. 4in.) length, more than half the kerb has less than a full upstand; or (ii) a length of continuous dropped kerb in excess of 9m (29ft. 6in.) is created.

NOTE 4a

Increase footway to 2.304m (7ft. 7in.) in width where (etc. as for 4)

NOTE 4b

Increase footway to 2.054m (6ft. 9in.) in width where (etc. as for 4)

NOTE 4c

In order that no space should be wasted, the foundations of buildings and walls can be partially located underneath the footway.

Sections through footways

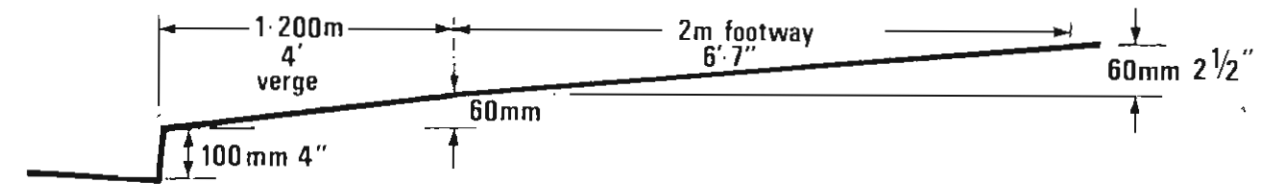

Type 1 road

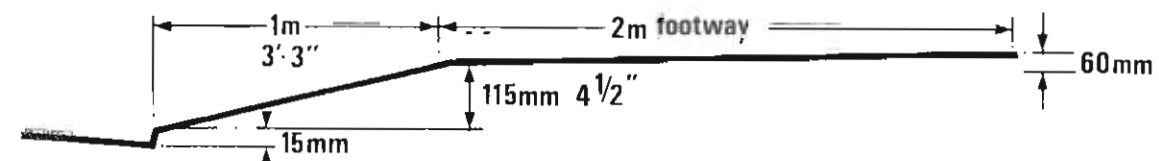
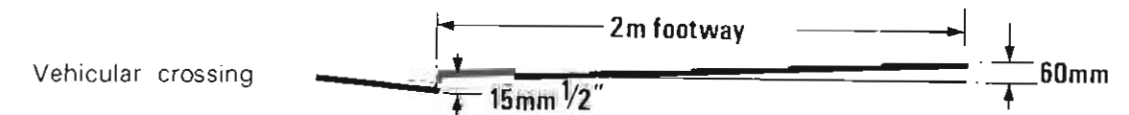
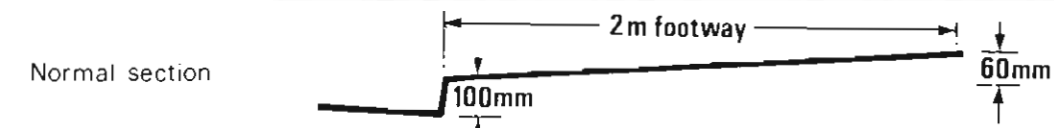

Type 2 and Type 3 roads

Widened section (see Note 4)

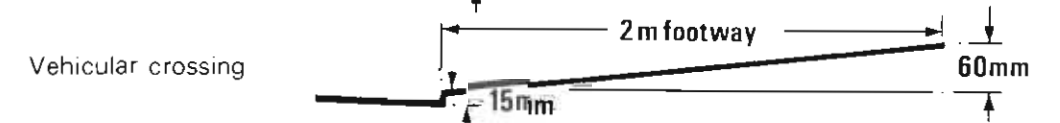

Type 4a road

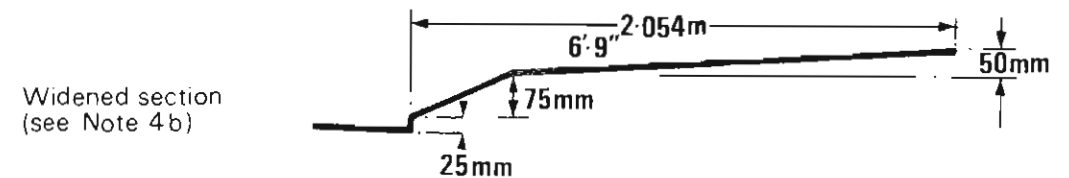
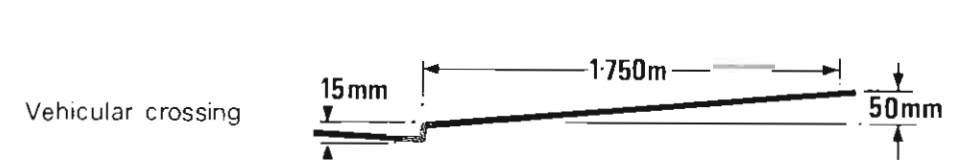
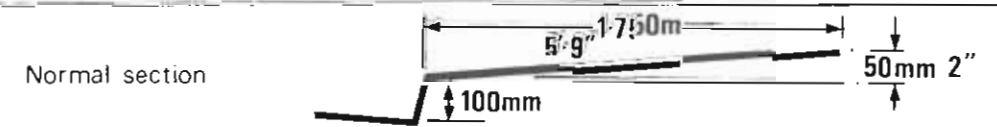

Type 4b road

NOTE 5

Type 5 MEWS COURTS.

These short length culs-de-sac are combined vehicle pedestrian areas intended to primarily cater for the motor car being driven at very low speeds.

In order to achieve this the entrance to the court is deliberately restricted in width - and must be contained within walls or buildings for the first 8m (26ft. 3in.) from the back of the footway. To slow down the speed of vehicles entering the court, a ramp and cross over type junction is required. Traffic will also be subject to a ramp placed 6m (19ft. 8in.) back from the edge of the footway. This, combined with the corner wall sight splay requirement, will allow the motorist and pedestrian to see each other in good time.

The restricted form of entrance will also tend to deter the large delivery vehicle from going into the court, especially as the maximum carrying distance is kept down to 36m. (118ft.) - the length of the court road.

Where a private drive is provided off the end of a mews court then a dustbin collection point may be required.

However, should it be necessary for the delivery vehicle to enter the court area - this is possible, and allowed for in the construction standards proposed.

Adoption of hard surfaced areas - including any carparking space not specifically related to the dwelling - is capable of being undertaken when required; this can extend right to the face of the buildings.

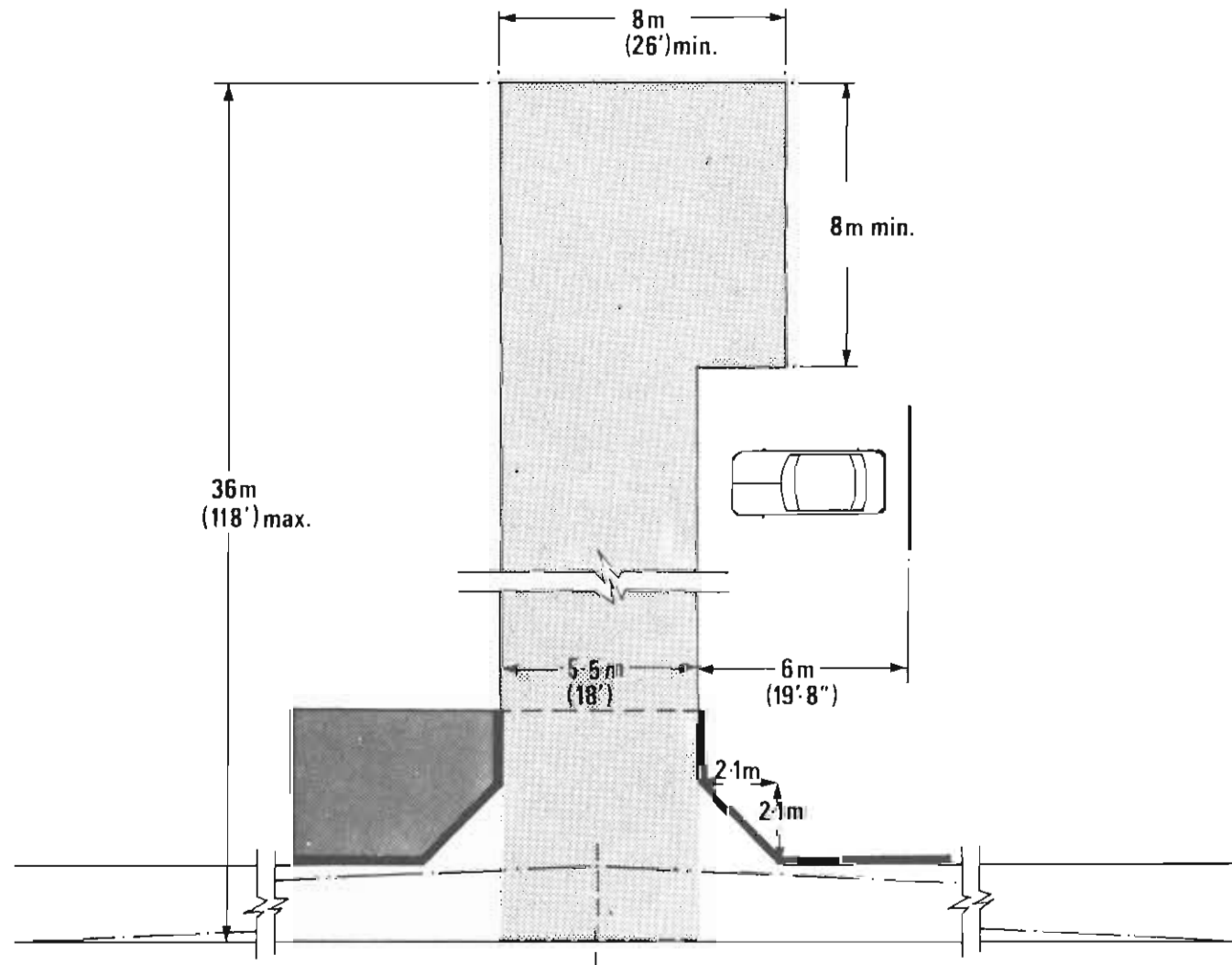

Key dimensions of Mews Court

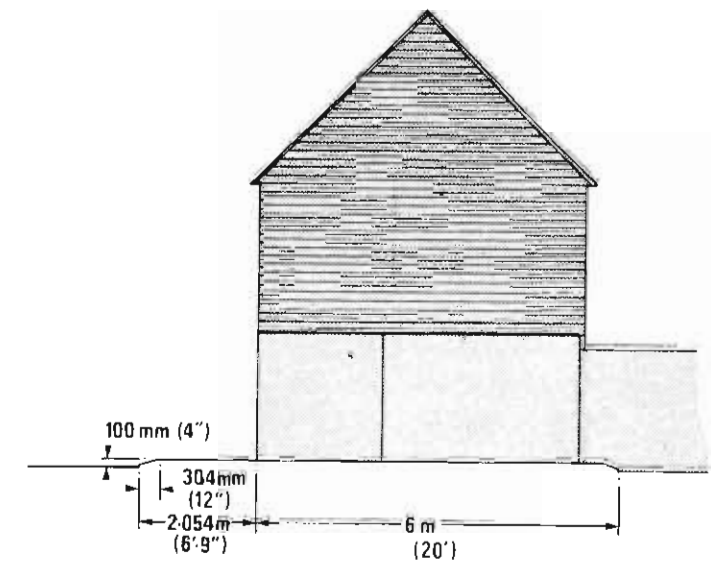

Section through entrance to mews court from type 4B road

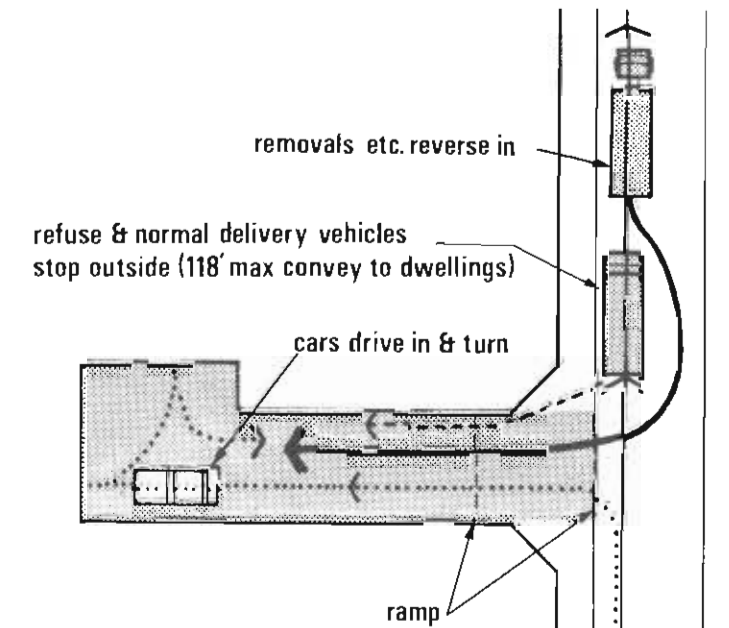

Vehicle movements associated with the mews court

NOTE 6

Mews courts can also be located off the end of turning heads provided the entrance is staggered to prevent vehicles entering at excess speed.

NOTE 7

It is suggested that single or shared drives which entail reversing over 18m. (59ft.) should be provided with turning facilities for each house served. Also for shared drives of considerable length or from which ends are not intervisible, passing places should be provided.

NOTE 8

An 36m (118ft.) elevation distance is to be provided between bends.

NOTE 8a

An 18m (59ft.) elevation distance is to be provided between bends.

NOTE 9

FORWARD VISIBILITY GRAPHS

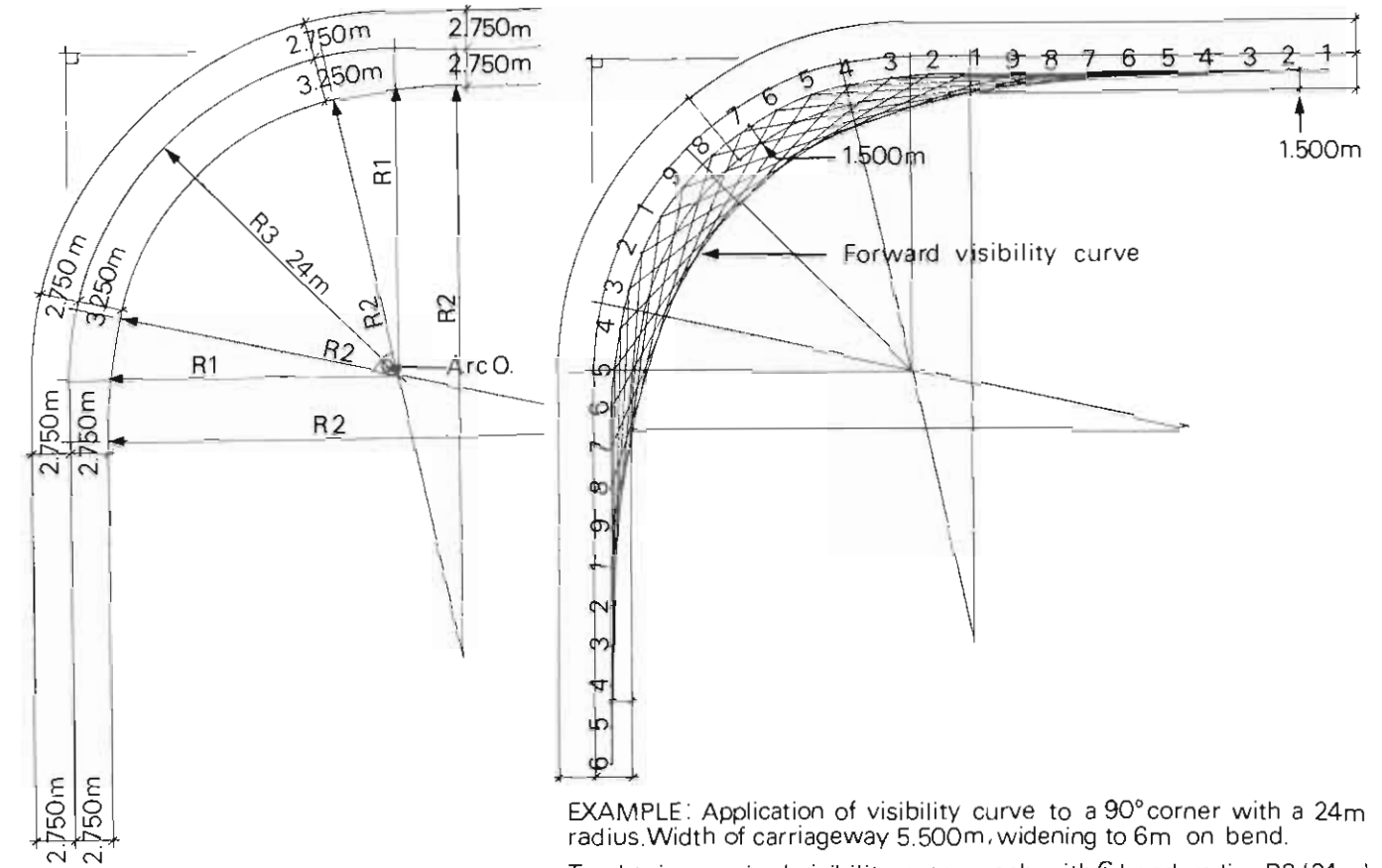
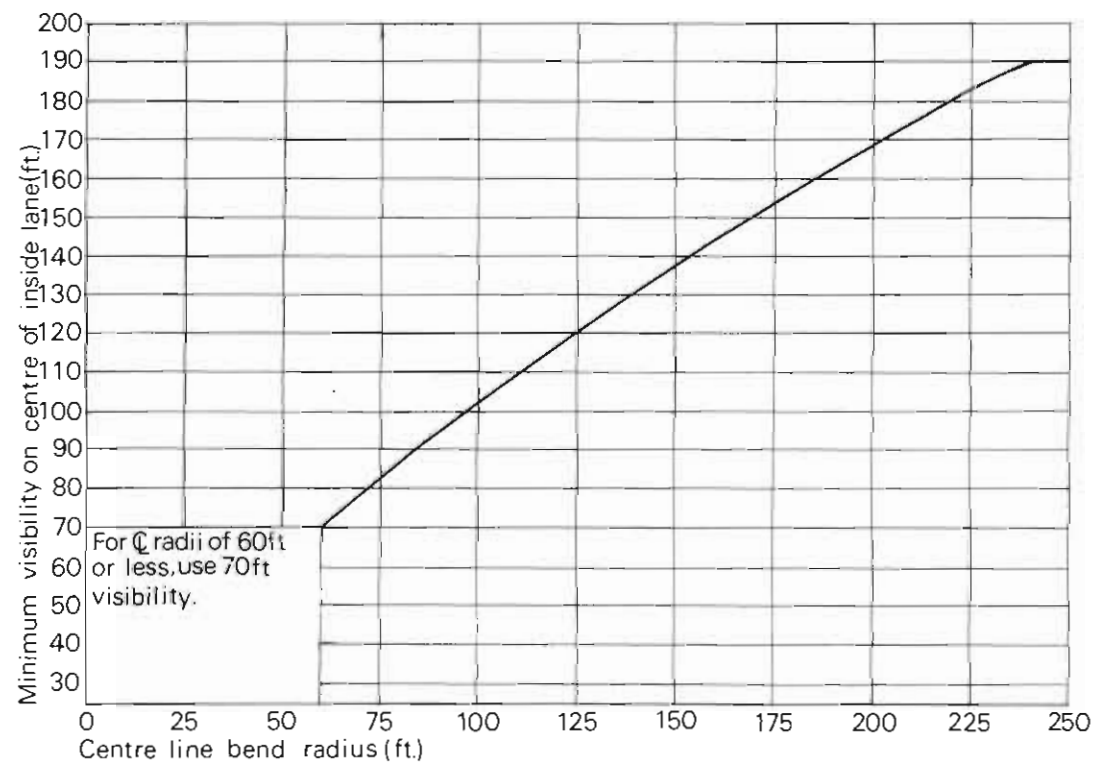
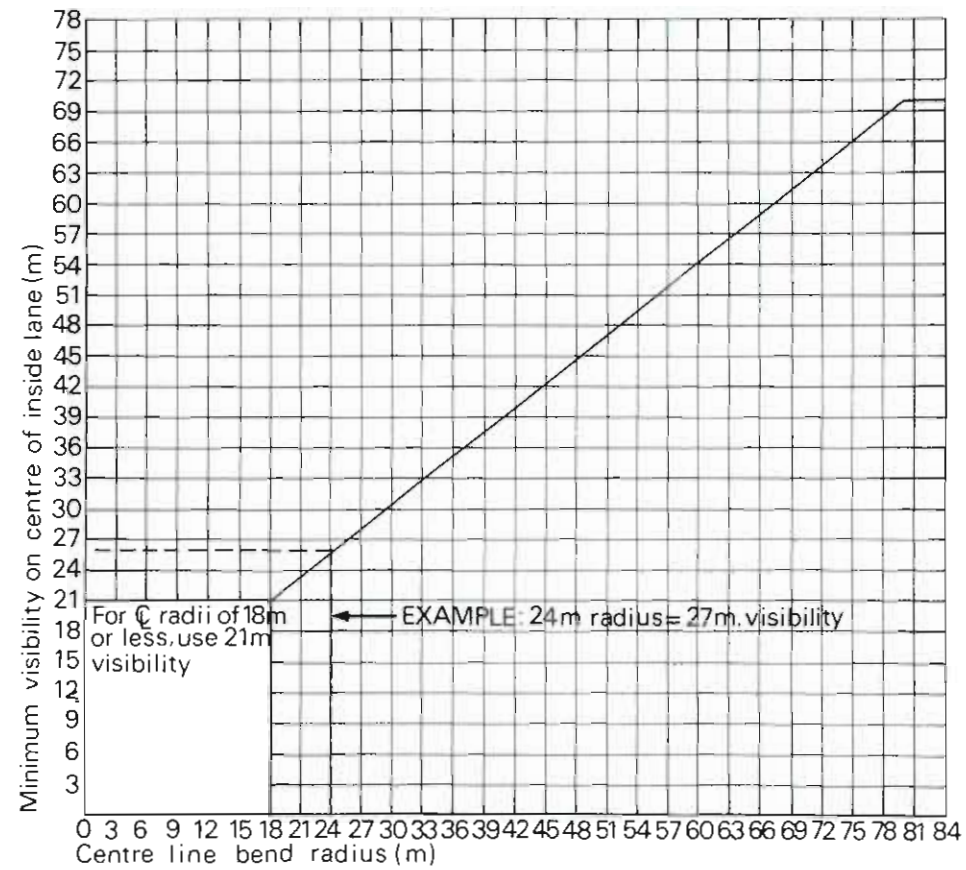

EXAMPLE: Application of visibility curve to a 90° corner with a 24m radius. Width of carriageway 5.500m, widening to 6m on bend.

To obtain required visibility, enter graph with C bend radius $R3$ (24m), read off visibility (26m) and round up to nearest 3m above (27m).

This distance to be achieved along the C of the nearside lane (1500m from kerb) thus:- Divide visibility into 3m intervals (9 points). With point 1 27m from start of bend, plot round numbering from 1 to 9 at 3m intervals, until a distance of 27m after the bend is reached. To generate curve join point 1 to 1, 2 to 2 etc. Where arc O is less than 10°, enter graph with $R2 + 2.750m$ to determine visibility.

NOTE 10

DIAGRAM ILLUSTRATING MINIMUM STAGGERS OF JUNCTIONS

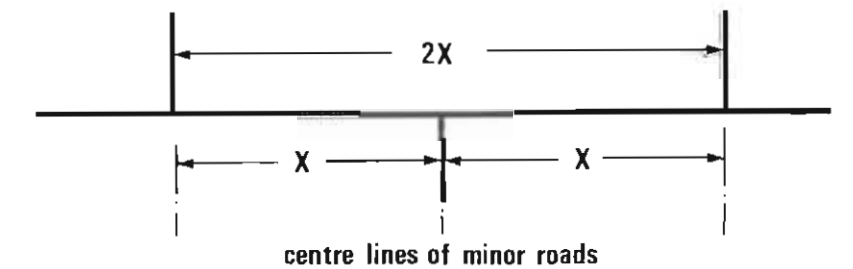

Minimum stagger between junctions on opposite side of road is 'X'
 Minimum stagger between junctions on same side is '2X'
 'X' is to be determined from the following table.

Side Roads at Junctions	Main Roads at Junction - 'X'			
	1	2	3	4a
TYPE 1	60m (197')	—	—	—
TYPE 2	60m (197')	30m (98')	—	—
TYPE 3	60m (197')	30m (98')	30m (98')	—
TYPE 4a	—	30m (98')	22m (72')	22m (72')
TYPE 4b	—	30m (98')	22m (72')	22m (72')

NOTE 11 & 12

DIAGRAM INDICATING VISIBILITY REQUIREMENTS AT 'T' JUNCTIONS

SIGHT LINES

Where Major road at T junction is a :-
Local distributor
Access Road Type 2/3/4A/4B

y distance
90m (295ft.)
70m (230ft.)

Where Minor road at T junction is a :-
Local distributor
Access road Type 2
Type 3
Type 4A
Type 4B
Type 5
Type 6

x distance
9m (29ft. 6in)
9m (29ft. 6in)
6m (19ft. 8in)
6m (19ft. 8in)
4.500m (14ft. 9in)
2.100m (6ft. 11in)
2.100m (6ft. 11in)

2.100m x 2.100m (6ft. 11in. x 6ft. 11in.) splay to be provided on each side at the junction with the back of footway of the major road.

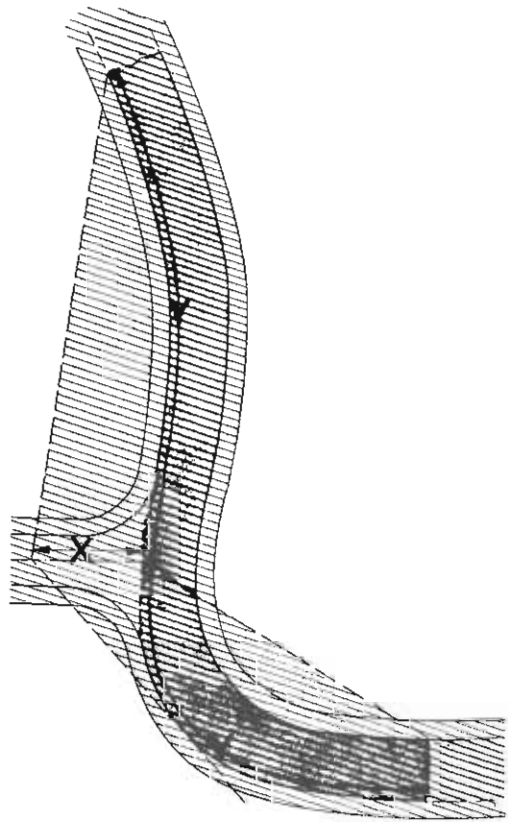

Area of carriageway to be visible from minor road
Area to form part of high-way

NOTE 13

DIAGRAM SHOWING LENGTH OF MINOR ROAD FROM 'T' JUNCTION REQUIRED TO BE STRAIGHT
The length of straight 'Z' to be not less than as shown in the following table.

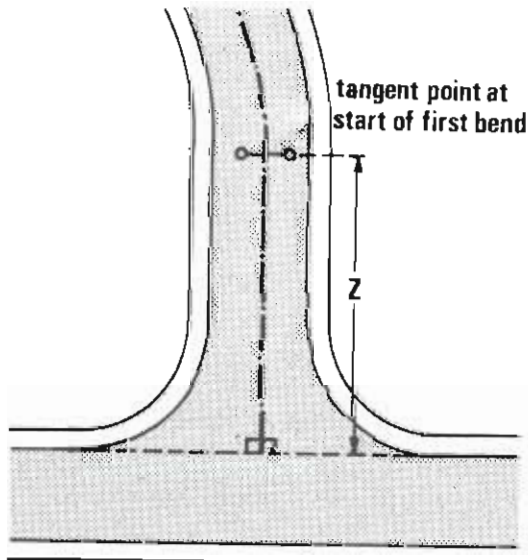

type of minor road	'Z'	
1	30m	100'
2 & 3	22m	70'
4A & 4B	15m	50'

NOTE 14

DIAGRAM ILLUSTRATING DETAILS OF COMPOUND CURVES REQUIRED AT THE JUNCTIONS OF TYPES 1, 2 AND 4B ROADS WITH OTHER ROADS.

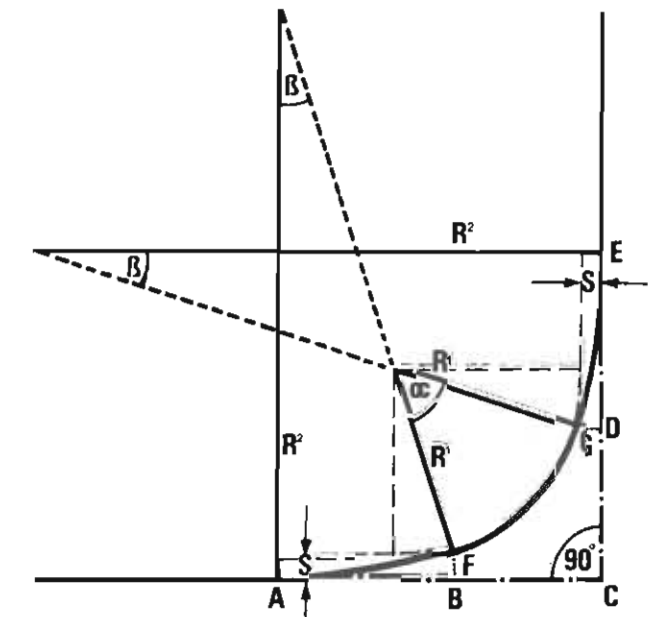

	S	R ¹	R ²	β	α	AC.CE	AB.DE	BF.DG
types 1 & 2 roads	1.028m 13ft 5in	10.500m 34ft 5in	31.500m 103ft 3in	18°	54°	17.983m 59ft	9.707m 31ft 10in	1.534m 5ft 1in
type 4B road	0.587m 1ft 11in	6m 19ft 8in	18m 59ft	18°	54°	10.276m 33ft 8in	5.547m 18ft 2in	0.876m 2ft 10in

NOTE 15

Footways on radius: to be reinforced to take vehicles.

NOTE 16

NOTES REGARDING TURNING BAY SIZE REQUIRED

'Y' metres	size of turning bay required at end of cul-de-sac
300 or less	1
300 to 500	2
over 500	3

On Types 2, 3, 4A and 4B roads the turning bay size required is determined on the distance 'Y' measured along the road from the end of the cul-de-sac to the nearest junction of sufficient size to contain a turning bay of size 3 dimensions as follows:

* certain districts will require size 2 turning bays to manoeuvre their standard refuse freighters.

Any cul-de-sac off a Type 1 road is to contain a junction or turning bay of not less than size 3 turning bay dimensions.
On type 5 roads a size 0 turning space will be required.

On type 4B culs-de-sac which are side turnings from type 3, 4A and 4B roads and which are less than 30m in length a size 0 turning bay may be used in place of a size 1 turning bay.
The length of a cul-de-sac is measured from the channel line of the road from which it begins.

NOTE 17

DIAGRAM ILLUSTRATING SIZE 0 TURNING BAYS

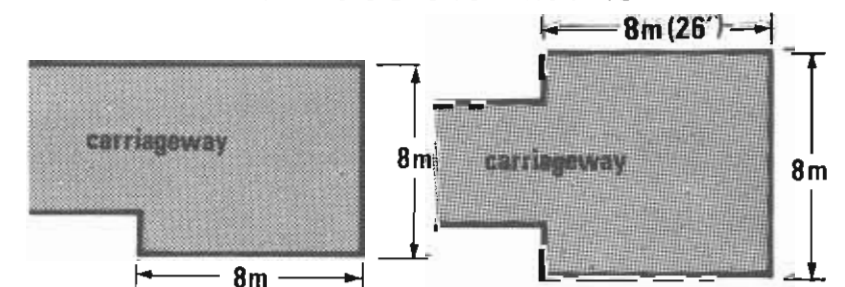

NOTE 18

DIAGRAM ILLUSTRATING SIZE 1-3 TURNING BAYS

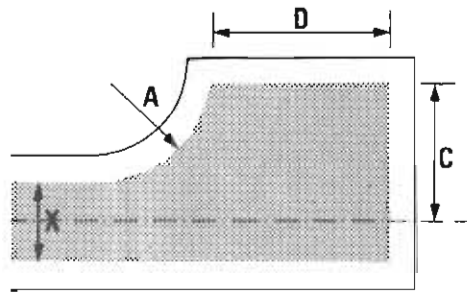

	1	2	3	
A	6 19-8	7.5 24-6	10.5 34-5	metres feet
C	9 29-6	11.5 37-9	14 46-0	
D	C + X/2			

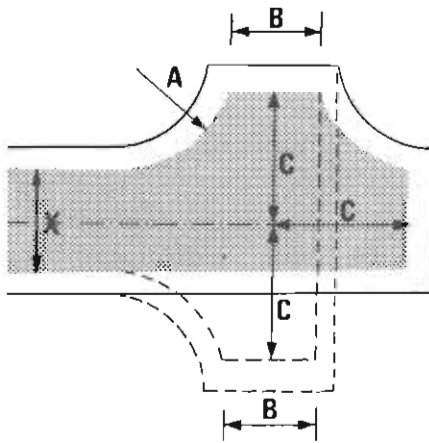

	1	2	3
A	6 19-8	7.5 24-6	10.5 34-5
B	X	X	X
C	9 29-6	11.5 37-9	14 46-0

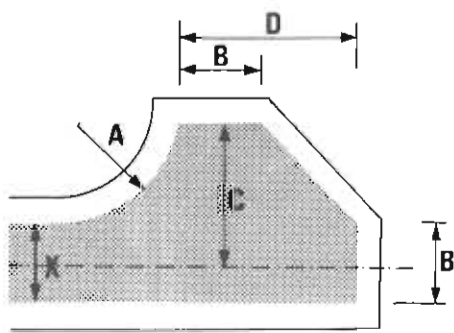

	1	2	3
A	6 19-8	7.5 24-6	10.5 34-5
B	X	X	X
C	9 29-6	11.5 37-9	14 46-0
D	C + X/2		

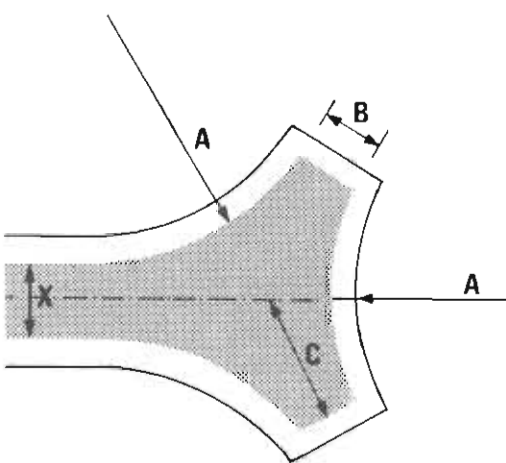

	1	2	3
A	10.5 34-5	10.5 34-5	10.5 34-5
B	X	X	X
C	9 29-6	11.5 37-9	14 46-0

NOTE 19a

House drives to meet back of footway at rightangles 2.100m (6ft. 11in) x 2.100m (6ft. 11in) sight splay required behind footway.

NOTE 19b

Vehicular access is not permitted across radius kerbs at junctions or turning spaces.

NOTE 20

These are maximum gradients, which may be subject to modification on sites which merit special consideration.

2.323

Car Parking

Within new housing areas, car parking should be provided in an adequate and convenient manner for both residents and visitors.

(i) The normal standard shall be one car parking space for each new dwelling in addition to a garage or a space for a garage.

The parking space should be within the curtilage of the dwelling or conveniently adjoining it and should be clear of the carriageway, footway and sight splays. In every case, the parking space should be convenient for use by occupants and visitors to each dwelling and must be constructed before the dwelling is occupied.

Where dwellings are built around pedestrian squares or are served off a segregated footpath access, then grouped parking spaces should be provided convenient for use by visitors to each dwelling.

(ii) In the case of dwellings specially designed for occupation by old persons the standard shall be one parking space for every two old persons dwelling units, any garages provided being additional to the parking space.

(iii) In the case of new dwellings built in those parts of rural areas not well served by public transport, the provision of two garage spaces in addition to two parking spaces will normally be required.

The policy therefore is as follows:

Car Parking

Within new housing areas, car parking in accordance with the Planning Committee's car parking policy and vehicular servicing shall be provided for residents and visitors, in a manner which is both convenient and visually satisfactory.

The following are the minimum dimensions and requirements for vehicle parking. For the detailed application of these standards, consult the Department of the Environment publication Design Bulletin No. 12 'Cars in housing/2'.

Parking Space

The minimum size of a parking space is 5m x 2.500m (16ft. 5in x 8ft. 2 1/2in). An additional space for opening the garage door will be required when the parking space is sited in front of the garage. Fig. 2.323a.

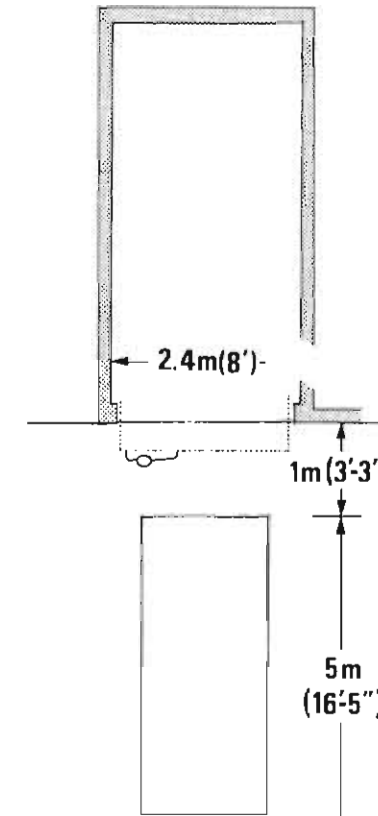

2.323 a Minimum parking space.

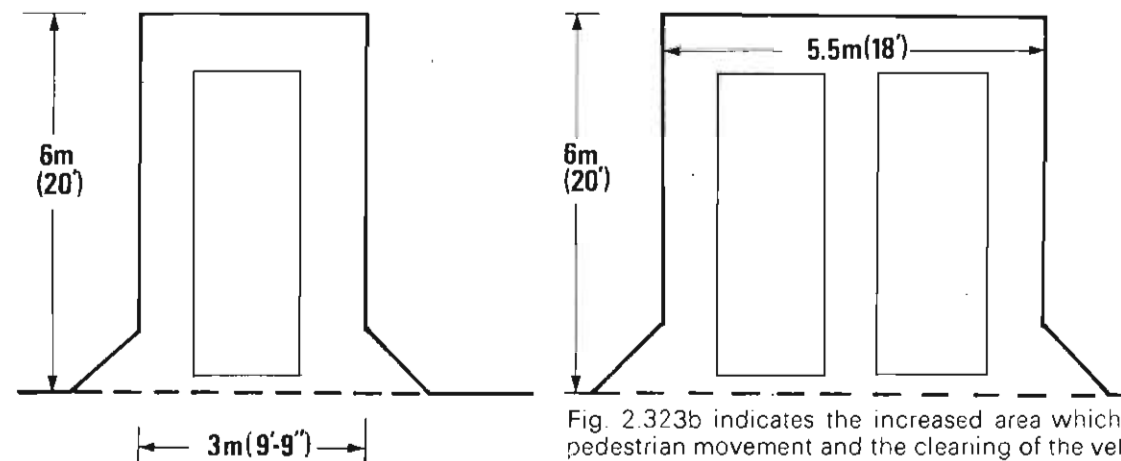

2.323b Parking space adjoining structures.

Fig. 2.323b indicates the increased area which is desirable for pedestrian movement and the clearing of the vehicle when structures or walls abut the parking space

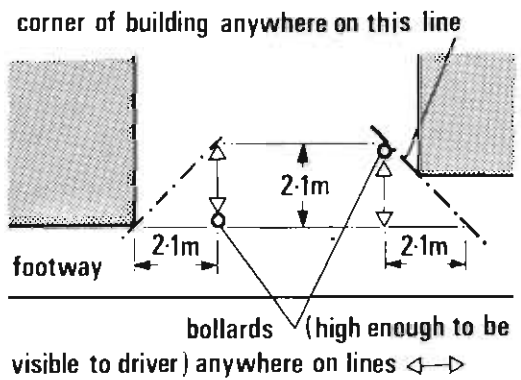
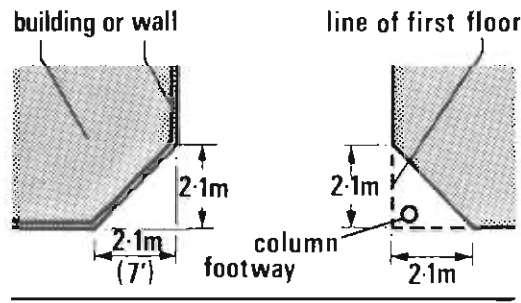

Methods of achieving 2.1m x 2.1m (6 ft. 11 in x 6 ft. 11 in.) sight splays

2.323 c

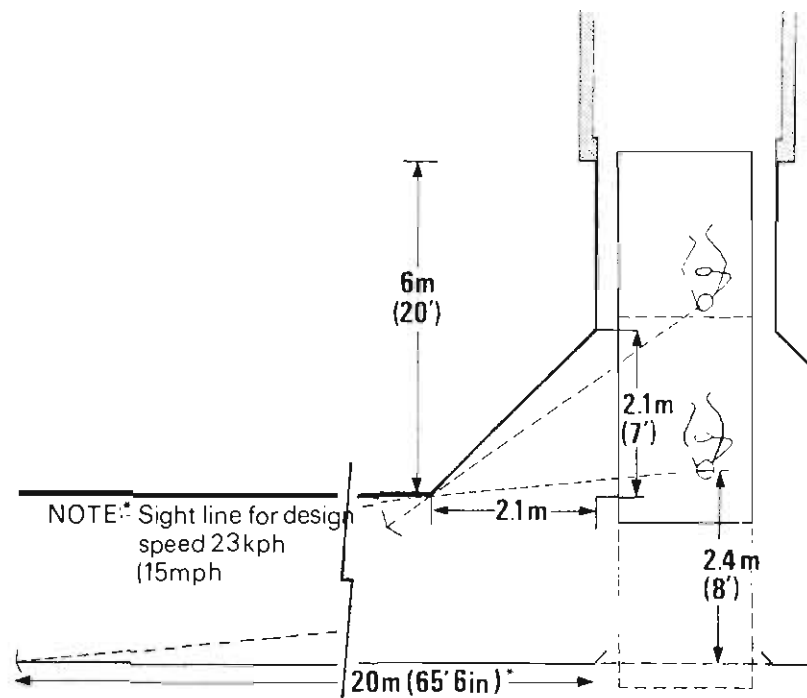

Fig 2.323c shows the garage and parking space sight splays which will be required.

It should also be noted that a sight splay of 2.100m x 2.100m (6ft. 11in x 6ft. 11in) will normally be required where a wall above 0.600m (2ft.) in height or a building adjoins the parking space or garage and abuts the pavement. Exceptions to this requirement will be garages and parking spaces in mews courts and private drives.

Parking spaces (and house drives) should normally meet the back of the footway at right angles.

To ensure casual parking spaces are used - in preference to roadside parking - the main entrance to such dwellings should be conveniently located. Fig.2.323d

Double garages and parking places should be laid out so that
(a) The use of one does not obstruct access to and from the other.
(b) The use of one does not obstruct access to both garages.
Parking bays will require to be lengthened where they abut turning areas and provided with drop kerbs to act as a distance stop, this will enable large vehicles to turn properly.

(i) unacceptable front door position, will encourage parking on the junction

(ii) wide frontage, shallow plan dwellings, should encourage the use of the casual parking space by the main entrance location

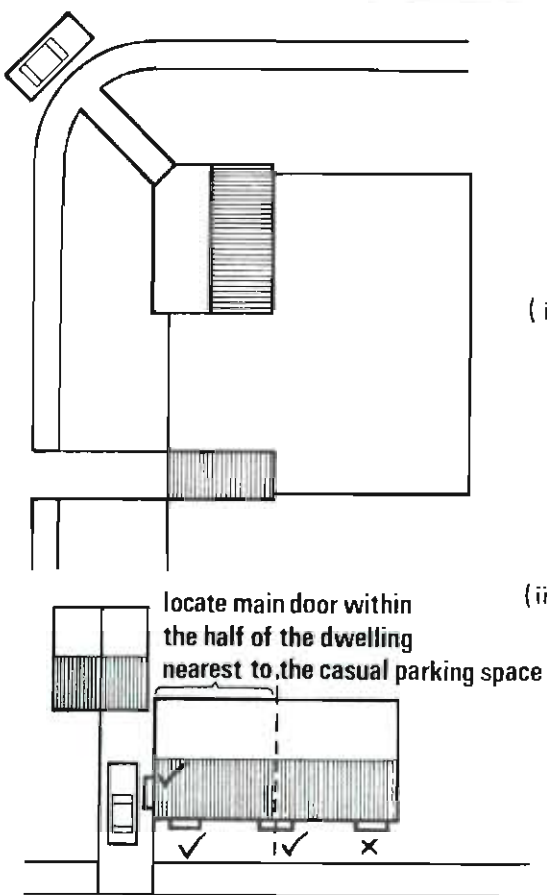

2.323 d

Dwelling entrance location in relation to the casual parking space



7.6m (25')

2.323 e Minimum garage court width.

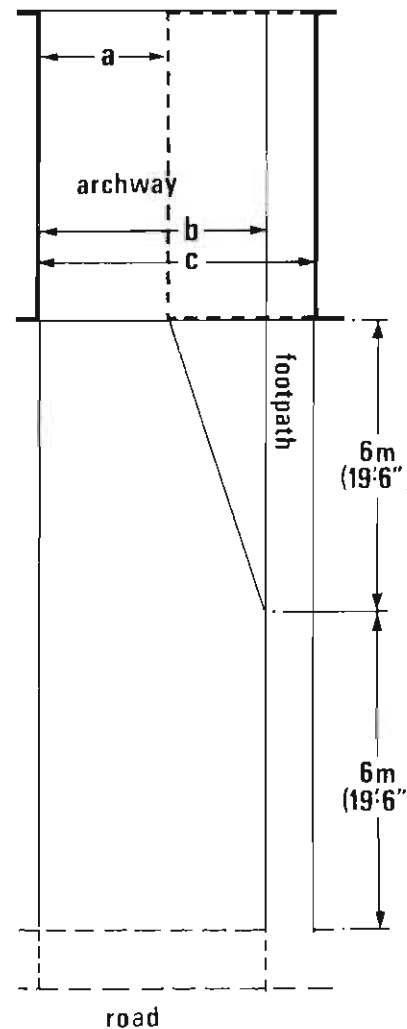
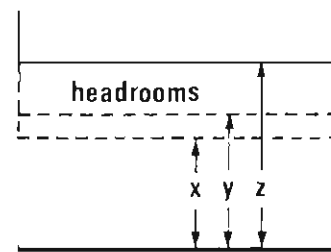

2.323 f Entrance widths to garage courts

Garages

The minimum internal garage size is 4.900m x 2.400m (16ft. x 8ft.)

The use of through garages - with doors back and front - is strongly recommended, when this can give access to the rear curtilage, for additional parking and storage.

Double Garages and parking places should be laid out so that
(a) The use of one parking space does not obstruct access to the other
(b) The use of one parking space does not obstruct access to both garages.

Communal garage courts

In courts a minimum width of 7.600m (25ft.) will be required between the fronts of garages - fig. 2.323e - although at this measurement, the end wall of garages courts will need to be recessed for most types of car to be able to manoeuvre properly.

Casual parking spaces shall not obstruct or be immediately in front of garage doors in communal courts.

The following design standards are suggested for entrance ways to garage courts:- (fig. 2.323f)

- (a) up to 6 garages and hardstandings as for shared drives (type 6 road) 2.500m (8ft 2½in)
- (b) 7-25 garages and hardstandings. Access way to be 4.250m (13ft. 11in)
- (c) over 25 garages and hardstandings. Access way to be 6m (19ft. 8in) in overall width, consisting of a 1.750m (5ft. 9in.) footway and a 4.250m (13ft. 11in.) wide carriageway, unless there is a direct secondary access to all houses from garage court, in which case the footway could be dispensed with and layout revert to (b) above.

For access ways to garage courts serving 7 or more garages and hardstandings: a minimum centreline radius of 7.500m (24ft. 7in.) is suggested, and for access ways to garage courts serving over 25 garages and hardstandings forward visibility for 15 k.p.h. (10 m.p.h.) should be provided.

Sight lines at junction of corner of access way to garage court with highway should be as required for a drive/mews court/minor access road serving the same number of garages and hardstandings.

Facilities for washing cars will usually need to be provided within communal garage courts. These should be sited clear of the required vehicular access and parking areas.

Headrooms

- X 4.115m (13ft 6in) for service vehicles
- Y 2.591m (8ft 6in) access to parking spaces
- Z 2.235m (7ft 4in) access to garages only

General delivery and collection vehicles

The maximum carrying distance from the delivery and collection vehicles to dwelling refuse points shall be in the order of 36.500m (120ft.)

Fire Engines

- (a) Access for fire service pumping appliances should be provided to within 45.720m (150ft.) of the entrance to all one and two-storey premises and to within 36.500m (120ft.) of the entrances of three and four-storey blocks of flats and maisonettes. These distances relate to the 54.850m (180ft.) length of hose reel tubing carried on appliances. It is therefore important that these be adhered to, so as to ensure sufficient tubing for internal fire fighting.
- (b) Blocks exceeding 12.800m (42ft.) in height will require special consideration in respect of access for Fire Brigade vehicles and rescue appliances.
- (c) Access for vehicles should be continuous; that is to say from one or more positions it must be possible to approach all dwellings sharing a common address name. It is not sufficient that different groups of dwellings sharing a common address should each be approachable from one of several positions. Access where possible should be to the fronts of dwelling; rear access is however acceptable provided that:
 - (i) the dwellings are numbered and readily accessible from the rear.
 - (ii) the rear service roads are separately named.
 - (iii) the dwellings are numbered in relation to the rear service road from which there is vehicular approach.
- (d) In cases where the planned estate roads and culs-de-sac will not give the above standards of vehicular access, then additional provision to allow emergency access by fire brigade engines should be made. In such cases the overall width of the fire path should not be less than 3m (10ft.) and changes in direction should be by bends not exceeding 8.500m (28ft.) radius to the outer edge. A minimum headroom of 3.500m (11ft. 6in.) will also be required. Supplementary information on the above requirements can be obtained from the Chief Fire Officer at Brentwood, under Guidance Note No. 26 accompanied by Standard diagrams Nos. 37, 38, 39 and 40.

Community Facilities

Amenity open space

A good housing layout is one where, there is no space in the 'public zone' which is not obviously useful and visually pleasant. On this basis, all public areas whether they be squares, pedestrian spine routes, streets or garage courts need to be treated as different types of space, all requiring a high degree of visual amenity. Therefore no fixed measurement standard relating to the area of amenity open space is proposed as this will obviously need to vary for each layout and situation.

Children's play space

The best place for small children to play is in the back garden, where they can be supervised without anxiety. To allow for this, back gardens need to be large enough. The minimum garden area standard is designed to meet this requirement.

It follows however that when family flats or new houses with patios or 'smaller' gardens are to be built, an increase in demand for children's play space will arise. In order to ensure that this social need is met, it is recommended that play space provision is made in accordance with D. of E. Circular 79/72.

Therefore, in such types of scheme containing ten or more bed spaces, play space should be provided on the basis of 3 sq. m. (32. 2sq. ft.) per child bedspace, such spaces being equipped from the list in

Appendix 1 of the Circular.

For the further explanation and application of this recommendation, the D. of E. Design Bulletin 27 - 'Children at Play' - should be consulted.

Play areas should generally be located off 'pedestrian spine routes', be enclosed by walling or buildings so as to provide noise and wind barriers, have a hard surface, and, if possible, be south facing. Such areas should also be capable of easy supervision from the passer-by; they should not be tucked away in left over corners of the layout. When play spaces adjoin roads they must be fenced.

Fig. 2.33 illustrates how this could be achieved in practice—the noise problem is overcome to some degree by having blank gable ends and garage walls backing onto the play space.

Seating

Seating is best provided at a useful resting point in a sheltered sunny position where there is something to look at—passers-by, children playing, or a long view, for example.

The policy therefore is as follows:

Community Facilities

In new housing areas, where a significant number of dwellings employ exceptions (i) and (ii) in relation to the minimum garden area (policy No. 2.22); conveniently located and appropriately designed children's play spaces shall be provided.

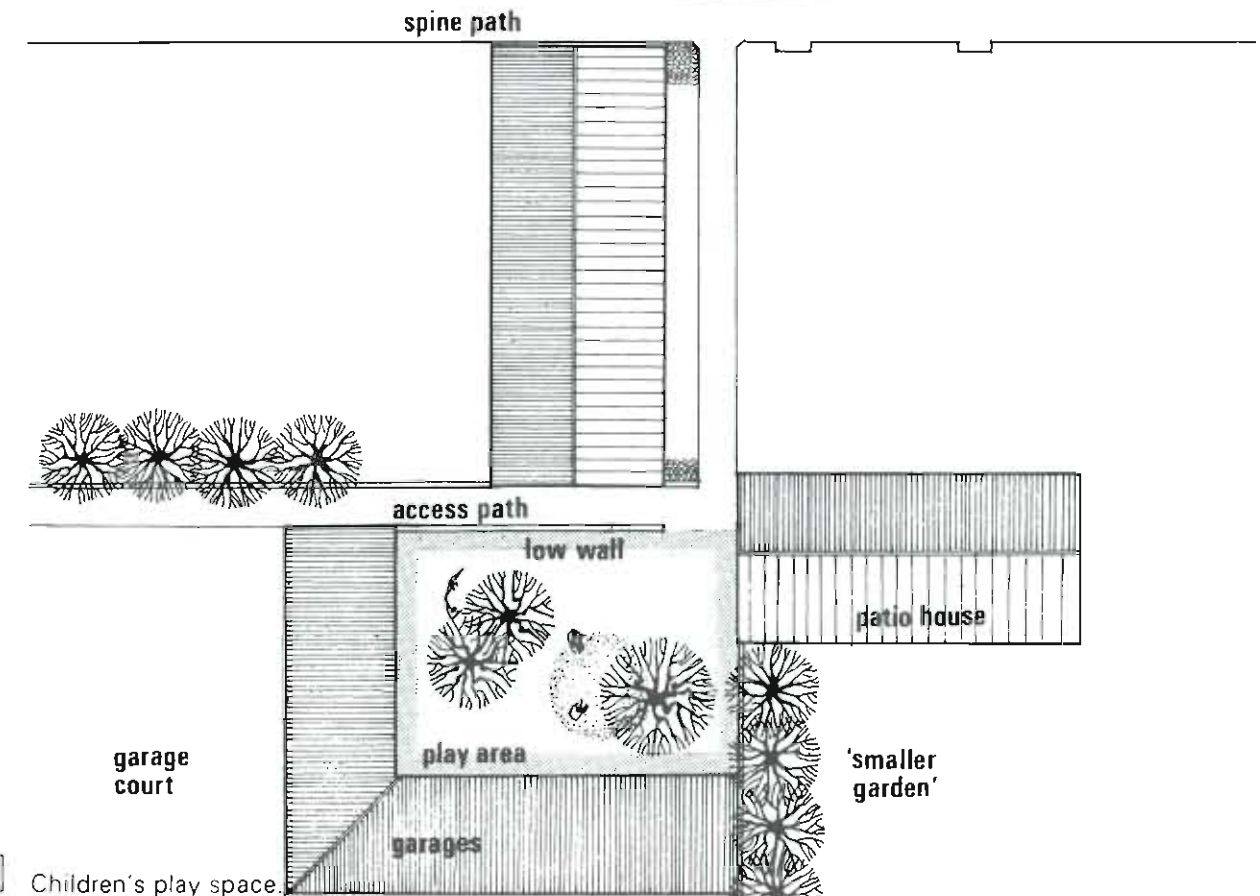

2.33 a Children's play space.

Adoption Standards and Maintenance

The principle of trying to ensure that the public areas of a housing development are designed and constructed so that they can be taken over and maintained by the local authority, is sound. The cost of this maintenance can then be charged through the domestic rate (or rental), along with those of the other public services.

In practice, however, the implications of the adoption requirements often became a source of disagreement - especially when detailed planning applications were made. Here it was claimed by architects and developers that the standards for adoption were applied too rigidly and that alternatives to the 'approved' methods were not allowed. This did not mean that something different would not get planning permission, but that as a result the maintenance would probably have had to be undertaken privately. Such arrangements can work well - if there is a continuity of interest - but often they do not. The result was that almost all developers chose to conform to the approved standards. For this reason all the adoptable 'bits and pieces' in existing housing areas tend to look alike - the same road widths, junctions, curves, alignments and surface finishes; the same type of turning heads; the same pavement and kerb details; the same street lights and ubiquitous concrete columns. Inevitably this imposed a stamp of engineered uniformity on the appearance of housing areas, which undermined any architectural efforts to create a place of individual character and identity.

Highway standards, formulated and approved in isolation, are invariably very space consuming and as a result the design and density of development will be adversely affected. Unimpeded vehicular movement at all levels can eat up the ground and in doing so take precedence over such social considerations as a decent sized private garden.

With these problems in mind, a broader, more flexible approach by highway authorities towards adoption is now proposed.

(i) Firstly, the planning authorities will continue to approve the size of roads within housing areas, bearing in mind the views of the highway authority, while the highway authority will continue to approve their construction and drainage for the purposes of adoption.

In respect of the former, the Department of the Environment's Circular 32/72 says that consideration is being given to dispensing with the control of street widths by means of byelaws made under the Highways Act 1959 and instead dealing with this aspect of development by means of planning control under the Town and County Planning Act 1971. It is possible that this measure will come into effect during 1974.

(ii) Secondly, 'approved' adoption standards will now be supplemented by means of minimum *performance criteria* for layout and construction.

The onus is now placed on the architect or his consultant engineer to prove their case by satisfying the criteria set down. This is the arrangement by which the Building Regulations operate at present. 'Deemed to satisfy' solutions are supplemented by performance standards which enable alternative methods of construction to be used at the discretion of the Building Inspector.

(iii) Thirdly, any normal increase in future maintenance costs after adoption by the local authority, incurred through the use of alternative forms of construction and materials will be met by that authority.

This will allow *alternative* hard landscaping solutions; such as granite kerbs instead of concrete, stone paving or sets instead of tarmacadam; which involve a higher initial cost than other materials, to be adopted. This principle will also be extended to cover soft landscaping; with trees, grass and shrubs in the public or amenity areas being maintained by the local authority. However, because of the amount of specialist

work involved in maintaining some types of planting, local authorities retain the right to insist that the developer should make private arrangements for undertaking this kind of estate management.

(iv) Fourthly, the use of 'covenants' restricting the erection or removal of fences or hedges, specifying the tree types to be planted and controlling other matters which affect the appearance of the 'public zone' side of housing developments, will be encouraged.

If required such covenants can be drawn up in consultation with the local planning authority, though their enforcement would be the responsibility of the nominated residents association, developer or land owner. This type of arrangement will be particularly useful for low density 'arcadian' housing schemes, where the visual effect depends on the collective planting efforts of each property owner.

The policy therefore is as follows:

Adoption Standards and Maintenance

It is the policy of the County Council to encourage Local Authorities to adopt and maintain those public areas essential to the appearance and functioning of housing estates. Where public adoption is not practical, alternative arrangements shall be required to ensure the proper maintenance of such areas.

PHOTOGRAPH

Highway dominated housing estate. Great Baddow. Chelmsford, Essex





Over the past few years, there has been growing concern about the appearance of new housing areas. Also, during this period there has been an increasing public awareness of the character and visual quality found in historic areas.

Therefore, as a starting point for improvement it is essential to understand the underlying visual principles of past and present built environments.

This section sets out the visual criteria by which residential development will be assessed and explains the reasoning behind the policy provisions.

In the following sections words like 'satisfactorily enclosing space' and 'well designed' will frequently be used. It might be thought these words imply an opinion: that one informed person might regard something as well designed and that another would not.

This is not the case; with all aspects of design there are well proven principles to be observed.

These principles governing design appear to have been so long neglected that the whole question of design is wrongly being regarded as a matter of opinion, or taste, with increasing visual chaos.

The principles of design are extremely detailed and complex; within the scope of this document it is only possible to consider the fundamentals as they may be applied to civic design or townscape.

The application of these principles will help to produce good buildings and good townscape but only an architect proficient in Urban Design can provide the subtle degree of refinement which can turn the principles into places which delight the eye.

3.1

The Principles of Spatial Organisation

Traditionally there have been two ways of organising space and buildings.



3.1 a Rural.

Rural System

One system is the low density or rural approach. Here the landscape contains the buildings. Buildings are set in landscaped space. For example, a mansion in its park or a group of farm buildings in their agricultural setting.

The key is: LANDSCAPE CONTAINING BUILDINGS.



3.1 b Urban.

Urban System

The alternative is the higher density urban approach. Here the previous principle is reversed with buildings containing the space. For example, the streets, squares, alleys and courts - which go to make up the character of our historic villages, towns and cities.

The key is: BUILDINGS CONTAINING SPACE.

COLOUR PLATES [above below

* Infill housing scheme, Clavering, Essex. Ingletons, Chartered Surveyors, Brentwood.

* Development at South Woodham Ferrers. Messrs. Rollings Construction Ltd. Ruffle & Dunbar Associates, Architects.

Unsatisfactory Suburbia



3.1 c Suburbia.

Recent housing development has failed to recognise these two basic principles. This has resulted in 'Suburbia'; where there are too many buildings for the landscape to dominate and yet buildings are too loosely grouped or of insufficient height to enclose space. THIS IS THE FIRST AND MOST IMPORTANT REASON FOR THE VISUAL FAILURE OF RECENT HOUSING DEVELOPMENT.

The Spectrum of Settlement Patterns

To expand this a little :-

The apparent increase in density from uninhabited landscape to the urbanity of the city may be viewed as a spectrum. Individual buildings in the landscape forming one extremity and the city centre the other, with all other types of settlement coming in between.

One end of this spectrum USES THE RURAL PRINCIPLE OF SPATIAL ORGANISATION. The other USES THE URBAN PRINCIPLE.

Towards the centre, there are too many buildings to be contained by the landscape and yet buildings are too loosely grouped to satisfactorily contain spaces. This then is SUBURBIA, fragmented architectural compositions set in a beleaguered landscape.

The failure to organise space properly is the most fundamental reason why suburbia fails visually.

This section will now examine more fully the principles of landscaped space and urban design and then look at the question of the detailed design of dwellings within this framework.

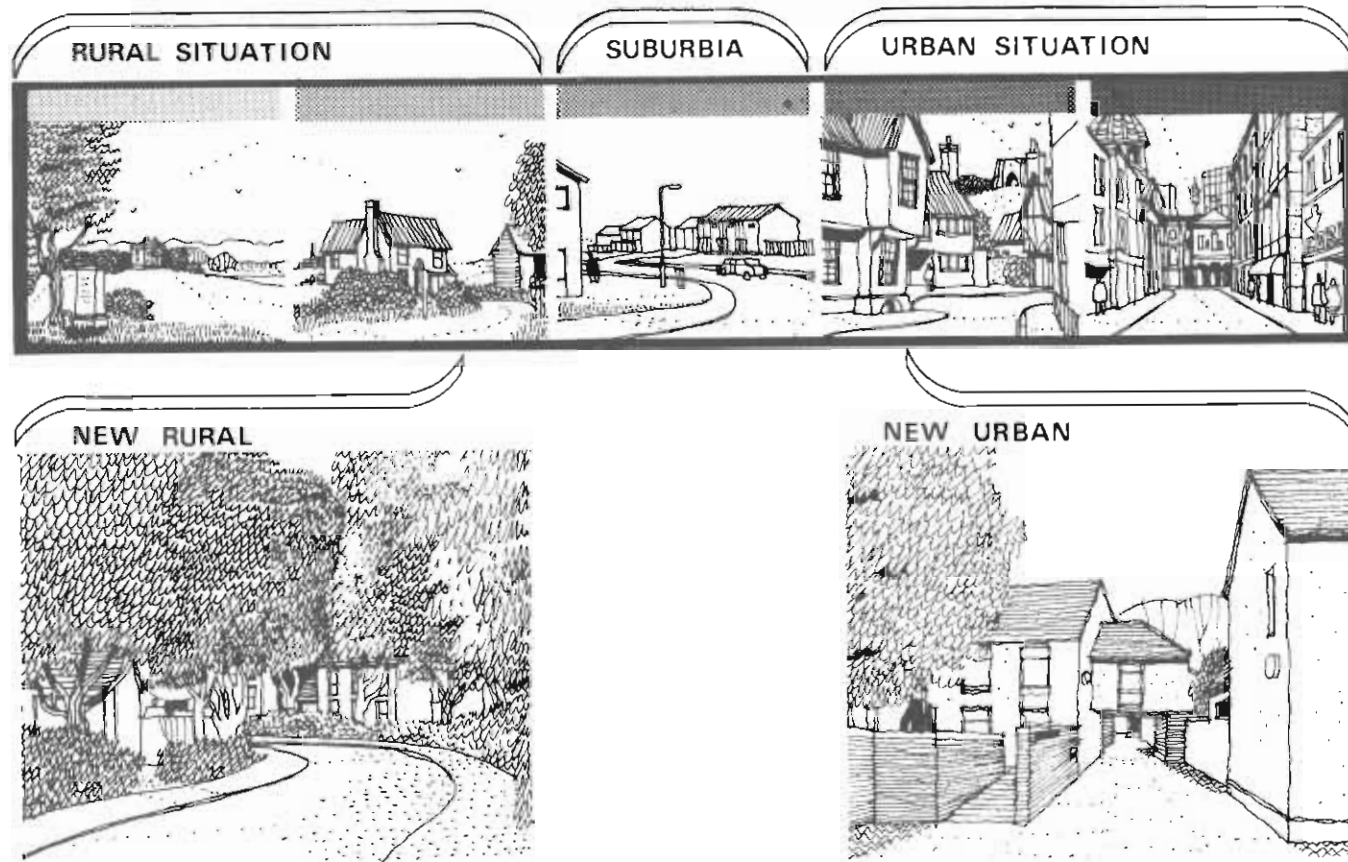

3.1 d The Visual spectrum of Settlement patterns.

3.2

Principle of Landscape Dominated Design

At the beginning of the 'spectrum of settlement patterns' - from rural to urban - is the truly rural situation, where an isolated dwelling or small group is located in the landscape.

This type of development will represent a very small percentage of the total of new building and is therefore generally outside the scope of this document. It is sufficient to say that on the occasions when buildings of this type will be permitted, the utmost care is needed to avoid the pitfalls of suburbia. The siting must be chosen to ensure that the landscape remains the dominant feature and space must be available for new planting to reinforce the existing.

The first type of development to be considered in detail is 'Arcadia' the conscious attempt to create the illusion of a rural environment in a residential area. Here the rural system of spatial organisation is employed as the landscaped space dominates and contains the houses. If this effect is to be achieved, building coverage must be strictly limited, and careful design is essential.

Arcadia takes two forms, the Informal and Formal.

3.2.1

Informal Arcadia

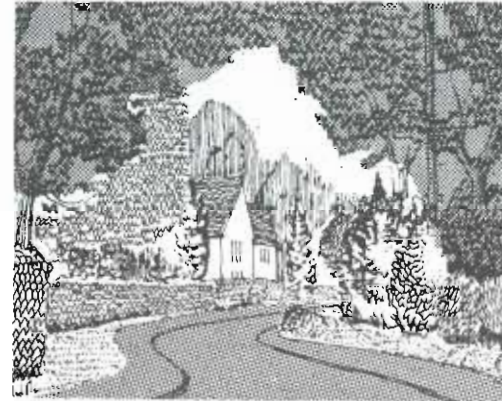

This is based on the picturesque theories of landscape design, as used in some of our country house parks.

These parks incorporated meandering walks which revealed temples, grottos and statues as surprise features set in a magnificent dominant landscape.

Similarly, in informal Arcadian housing, winding roads among the trees are designed to allow the 'villas' to appear at intervals as the surprise features in the landscape. Fig. 3.21a This effect cannot usually be achieved if the density is above 7-10 houses per hectare (3-4 houses per acre).

3.21 a

3.2.2

Formal Arcadia

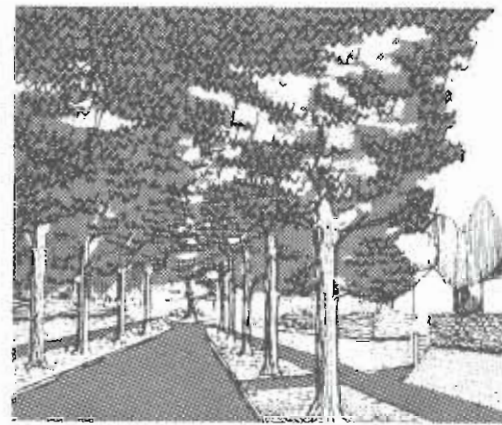

Formal Arcadia employs the rural principle of spatial organisation, as the landscape dominates the buildings. However, it also uses some of the urban principles of design insofar as trees are used to contain spaces in a manner similar to the way buildings are used in the urban situation.

Fig. 3.22a shows the principles. Avenues of trees line the roads and contain the space for the motorists. At intervals, islands of trees appear to terminate vistas - buildings are scarcely noticeable. The pedestrian is contained within an inner space formed by the roadside trees and front garden hedges and trees; houses appear at intervals at drive entrances but no more than one or two are apparent at any viewpoint. Trees always provide the link between one house and the next with more planting to the rear to unify the composition and contain the space between dwellings. A variation of this system is shown in Fig. 3.22b. Here the avenue of trees in the verge is omitted - but front gardens are longer and large trees can grow as part of the front boundary: pedestrians share the 'visual' road space with the motorist.

The length and variety of linear spaces needed to avoid monotony is broadly governed by the principles explained in the Urban Design Section 3.3

Due to the more rigid road layout, density can be higher than for the picturesque system - 10-19 houses per hectare (4-6 houses per acre).

Informal and formal arcadia are acceptable expressions of the rural system of spatial organisation which enable the landscape to be the dominant visual element.

NOTE: A guide to planting for Arcadia is contained in Section 4.191

3.22 a

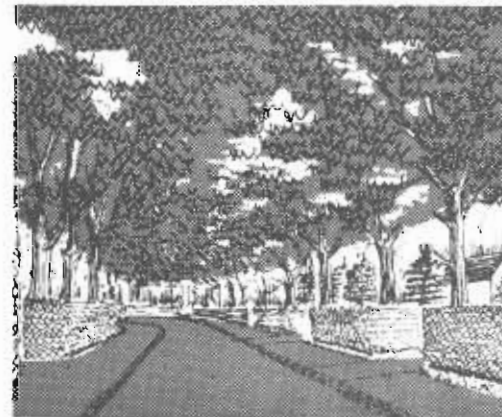

3.22 b

As already explained, the prime underlying principle of all urban places is the *enclosure of space by buildings*. If space is not *satisfactorily* enclosed, an attractive urban place cannot be achieved.

3.31 Principles Regulating the Creation of Urban Space

3.311 Human Scale

Physical expediency apart, the total amount of public space in an urban area must be broken down into a series of visually separate spaces in order to relate to the scale of the human being. To be in scale with the human being, the size of the place will have to be such that it is neither too large, nor too small, relative to the size of man. If too large, there will be a loss of comfortable contact with the surroundings, and a tendency towards a feeling of agoraphobia. If too small, the reverse sensation, a feeling of oppression or claustrophobia.

3.311 a

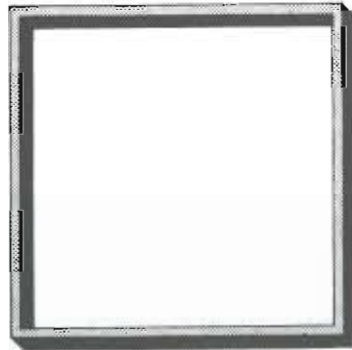

3.311 b

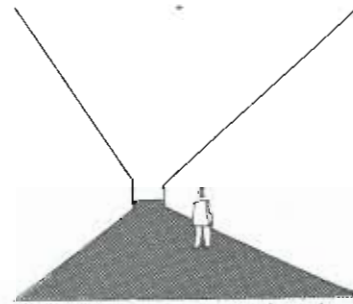
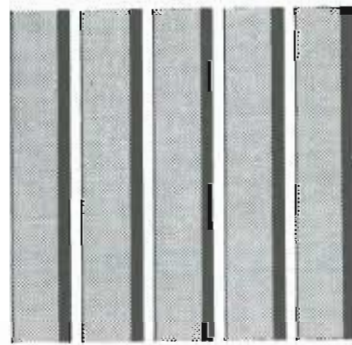

These spaces are unrelated to the human scale and speed of pedestrian movement. The square is too wide. The streets are too straight and long.

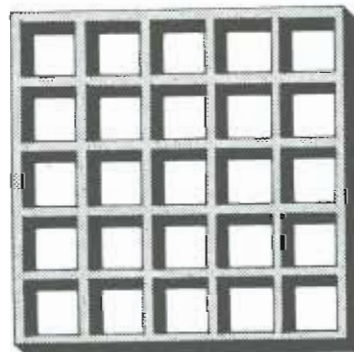

3.311 c

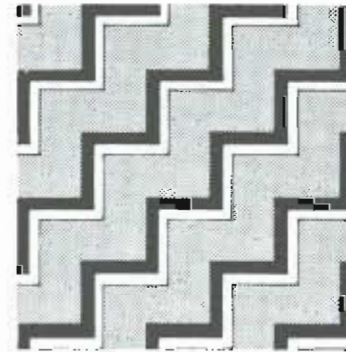

3.311 d

In Figs 3.311c&d the total space is broken into individual spaces each related to the human scale

These spaces related to the human scale will tend towards being :-
(a) static - for example, the square; (fig 3.311c)
(b) dynamic - the street. (fig 3.311d)

Note that in Fig. 3.311d the cranking of the linear spaces relates the length to the human scale and speed of pedestrian movement.

3.313 Contrasting Spaces

Although the spaces in diagrams 3.311c&d would be related individually to the human scale and might well be attractive, collectively these identical spaces would make a very monotonous place to live and move about in. Therefore NEW URBAN RESIDENTIAL AREAS SHOULD CONSIST OF A SERIES OF SATISFACTORILY ENCLOSED, CONTRASTING SPACES, EACH RELATED TO THE HUMAN SCALE.

3.313a

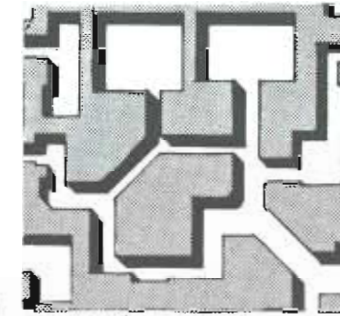

Contrasting spaces.

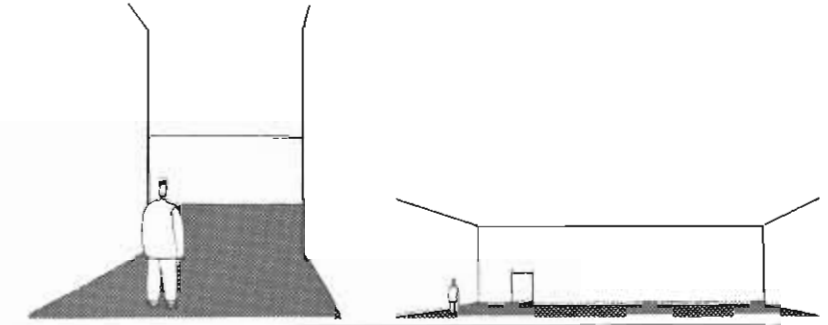

3.314

Height of Buildings and Width of Spaces

Having established the requirement for urban places to consist of a series of contrasting static and linear spaces related to the human scale, it remains to determine the physical dimensions and proportions which will give such a scale.

The relationship between the 'effective height' of the buildings and the width of the space is critical, if a harmonious urban place is to be created. If too high in relation to width, a feeling of oppression may result; if too low, a feeling of exposure and vulnerability.

The actual height-width ratio which will give this harmonious effect will be modified by the type of space, whether static or dynamic. Static spaces, because of their finite length, will be relatively more claustrophobic and will need to be compensated for with less height to width. Dynamic spaces, on the other hand, due to the subconscious ease of escape, seem less claustrophobic and will demand greater height to width if a harmonious balance is to be obtained.

In practice, the harmonious relationship of height to width for static spaces is of the order of 1.4. For dynamic spaces 1.1 will not appear too tight and 1:2.5 is as open as can be tolerated, if good enclosure is to be achieved.

NOTE: See Appendix (A) for the measurement of effective height.

3.315

Length of Spaces

As previously mentioned, all urban places will *tend* towards being static or dynamic spaces. For example, a 'square' which has one axis longer than the other will be a static space tending towards the dynamic.

Similarly a short linear space is tending towards the static.

In practice, if the long axis of a static space exceeds its short axis by much more than 50%, it will be comprised to such an extent that it should be regarded as a linear space with regard to height to width, if the correct degree of enclosure is to be retained.

The visual length of a dynamic space should be limited by complete or partial closure, formed by curves in the street, changes in the building line or changes of level.

The length should be related to the expected speed of movement along the communication route, the minimum length being for pedestrian routes and the maximum for traffic.

Long corridor spaces can be very daunting and monotonous at the pedestrian's speed of progress fig 3.315b

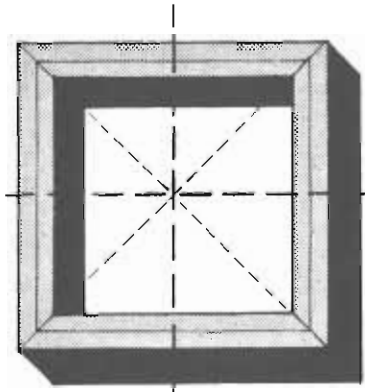

Static space.

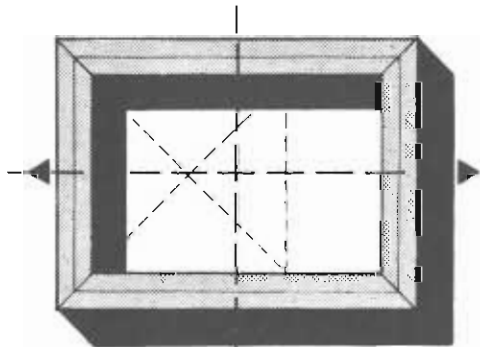

Static tending towards dynamic.

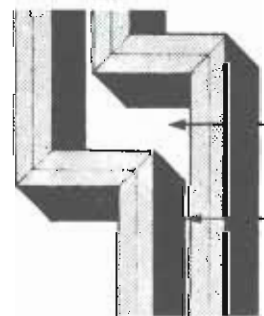

Linear tending towards static

Linear space

3.315a

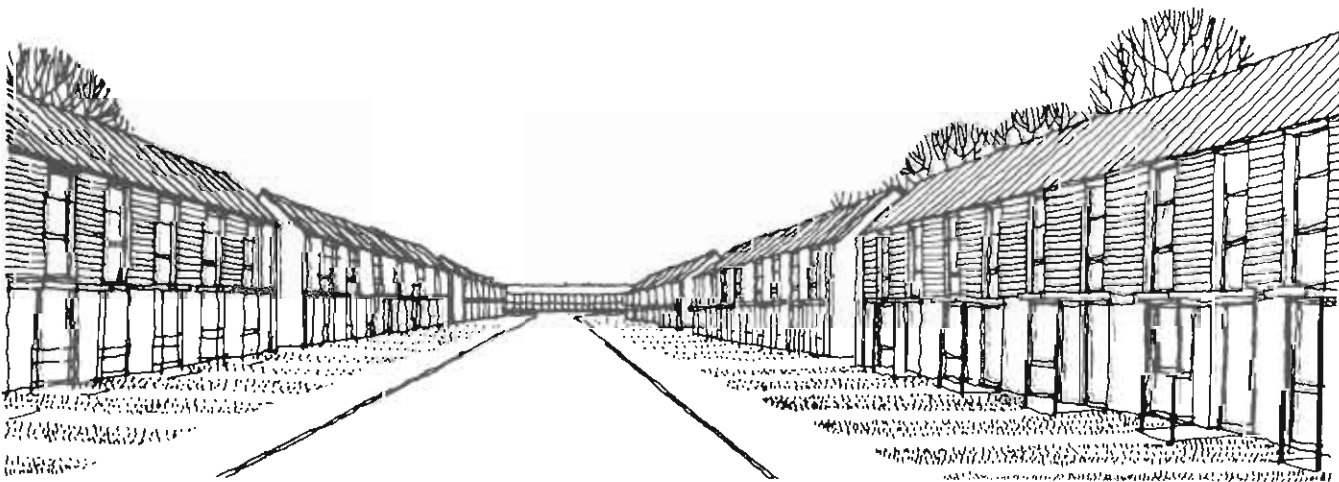

3.315b

Such long vistas can prove psychologically exhausting and make contrast of spaces difficult to appreciate due to the long time taken to get from one space to the next.

3.316

Architectural Use of Trees

The principles of urban design examined so far relate to the basic visual structure of places, that is the planes defining the spaces. fig 3.316a These planes will normally be made up of groups of buildings or walls. The planes can, however, be composed in part by trees, the trees taking the place of buildings - in fact the architectural use of trees.

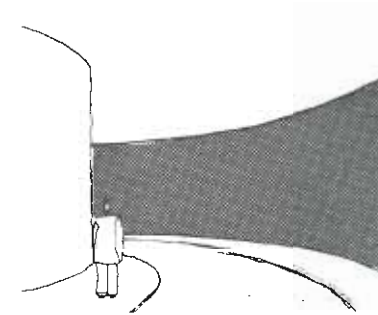

A space defined by planes of the building and planes of the ground.

3.316 a



Buildings defining the space.

3.316 b



The architectural use of trees.

3.316 c

Trees will normally be used architecturally in two ways:
 (1) (as illustrated above 3.316c) to visually complete built frontages, and
 (2) a very important use, to *modify built spaces*.

PHOTOGRAPH The Architectural Use of Trees, Town Street, Thaxted.

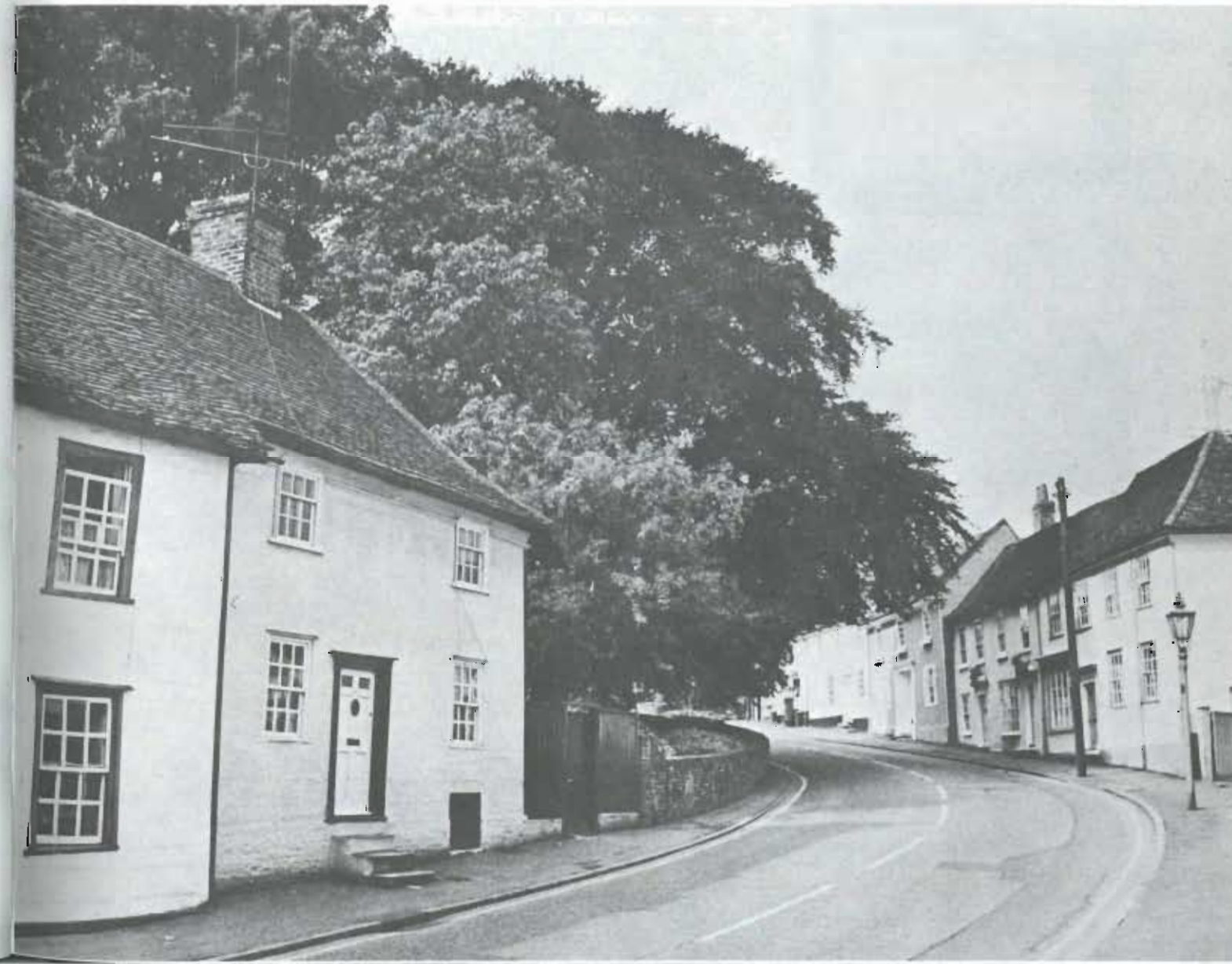

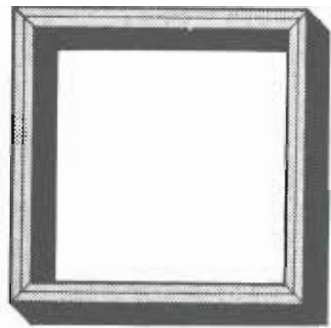

3.316d

For example, Fig. 3.316d is a large square with buildings of insufficient height for the width of the space to give a comfortable degree of enclosure.

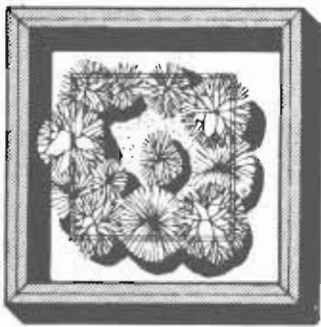

3.316e

In Fig. 3.316e, the same space is modified by trees to form a satisfactory circuit linear space related to the human scale.

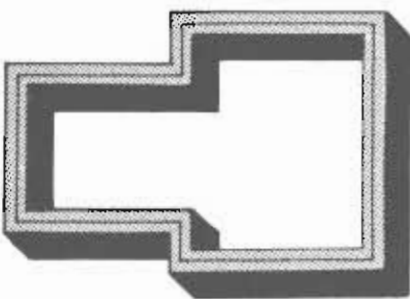
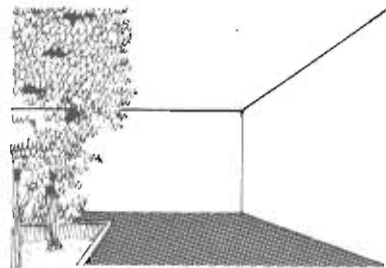

3.316f

Fig. 3.316f shows a 'square' where the static concept is compromised by the space being too long, yet the buildings are too low for a linear space.

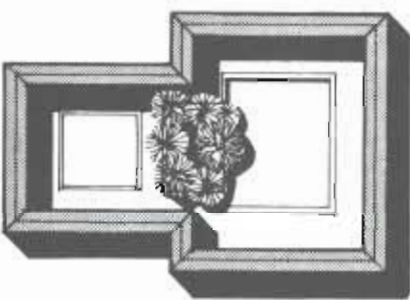
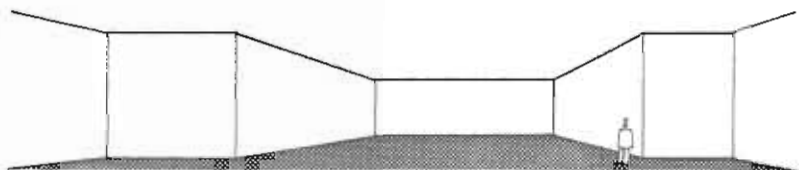

3.316g

In Fig. 3.316g the space is modified by trees to form two visually satisfactory static spaces.

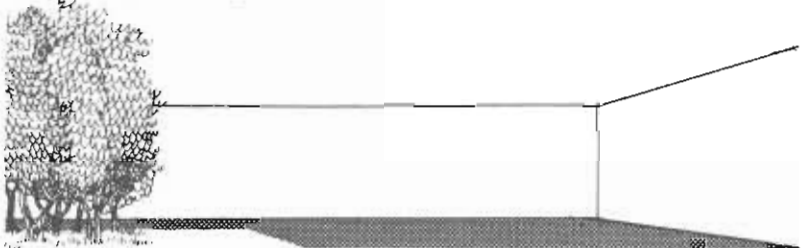

3.32

Architectural Composition Within the Discipline of Urban Spatial Enclosure

As, stated in section 3.313, to form attractive places and to avoid monotony, an area should consist of a series of contrasting spaces, proportioned to give the appropriate degree of spatial enclosure. Where this ideal can be achieved, the enclosing planes can consist of a series of identical dwelling units, grouped to form the larger compositions of these enclosing planes.

In practice there is a limit to the number of basically differing spaces, therefore there is bound to be near repetition and monotony, particularly in residential areas where severe limits on the widths of spaces will be imposed by the lack of height of the enclosing buildings. Therefore there is a limit to the amount of 'spatial identity' possible.

In this example, identical units are grouped to form the larger composition of the sides of a square. The Georgian square uses this principle.

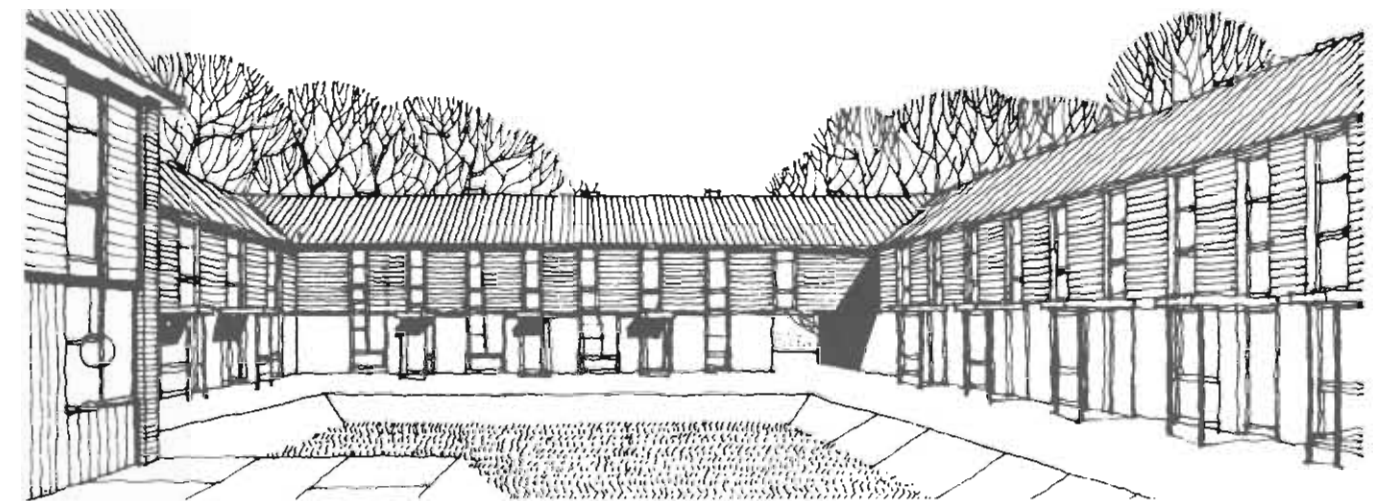

3.32 a

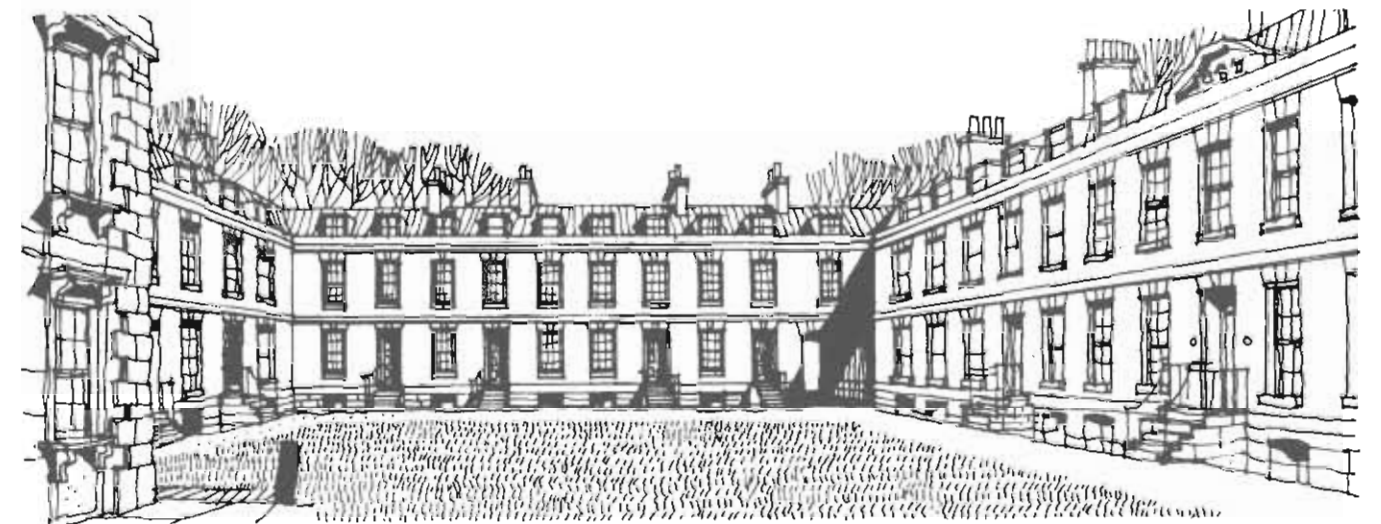

3.32 b

3.321

Architectural Identity

In addition to the basic structure of well proportioned spaces, comes the requirement that IN THE URBAN SITUATION INDIVIDUAL BUILDINGS SHOULD BE DESIGNED TO FORM ARCHITECTURALLY COHESIVE GROUPS TO GIVE ADEQUATE VISUAL INTEREST AND A UNIQUE IDENTITY TO EACH PARTICULAR SPACE.

As a result, the permutations of all the possible spaces and all the possible architectural compositions will give an almost limitless number of places, each having its own special character or identity.

The following example shows two identical spaces in terms of their enclosing planes and how different identity is achieved for each place by using different architectural compositions.

A SPACE WITH A PASSIVE ARCHITECTURAL FRAMEWORK

- A limited range of materials.
- Simple elevations.
- A limited number of house types.
- Wider visual bay widths
- Minimal changes in the building line.
- Little skyline interest.



3.322a

AN ASSERTIVE ARCHITECTURAL FRAMEWORK.

- A greater variety of house types
- Narrower frontages and bay widths.
- Emphatic changes in the building line.
- A raised skyline.
- A greater variety of materials.
- More elaborate facades.



3.322b

Identity by use of landscape

As mentioned in section 3.316, trees may be used as part of the enclosing planes. The proportion of tree enclosure to building enclosure will also affect the identity of a space, giving it a 'hard' or 'soft' character.

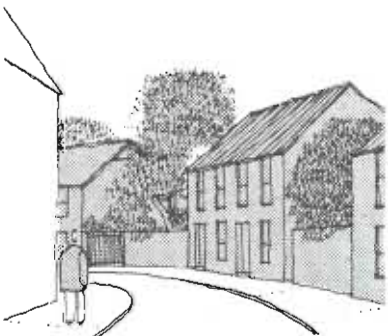

3.322c

Treatment of the 'ground plane'

The character of a space will be affected by the detail design of the 'ground plane'.

THE SURFACE TREATMENT OF THE 'GROUND PLANE' OF A SPACE SHOULD REINFORCE THE CHARACTER SET BY THAT SPACE AND ITS BUILDINGS.

For example, formal geometric treatment for a formal space: an informal approach for an informal space.

Linear shapes will reinforce the character of linear spaces and static shapes static spaces.

The ratio of planted surfaces to paving will affect the 'hard' or 'soft' nature of a place.

Modifying Linear Spaces by means of Architectural Composition

As mentioned in section 3.315, the length of Urban Spaces must be carefully controlled. It is often difficult to *adequately restrict the actual visual lengths* of linear spaces in order to relate them to the human scale and speed of pedestrian movement.

In these circumstances, it is essential
 (a) TO REDUCE THE APPARENT LENGTH as far as possible, and
 (b) TO COMPENSATE FOR ANY MONOTONY BY ADDED VISUAL INTEREST in the architectural compositions.

Reduction of apparent length can be achieved by dividing an overlong linear space into a series of 'sub-spaces' by subtle variations in the width of the street and the alignment of buildings.

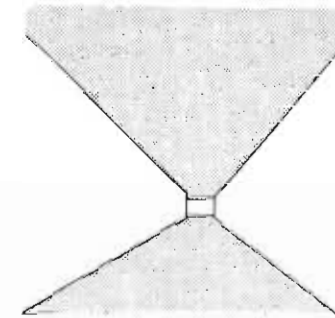

3.322d

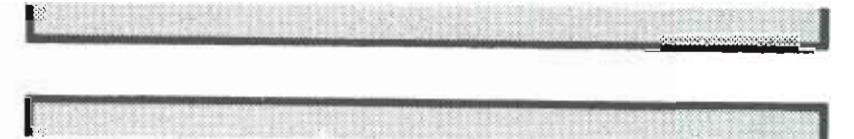

Long and monotonous linear space, unrelated to the human scale and speed of pedestrian movement

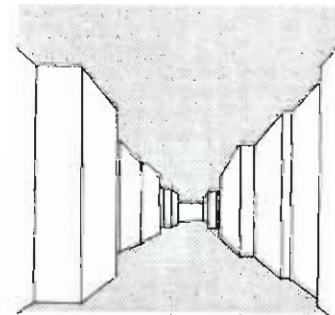

3.322e

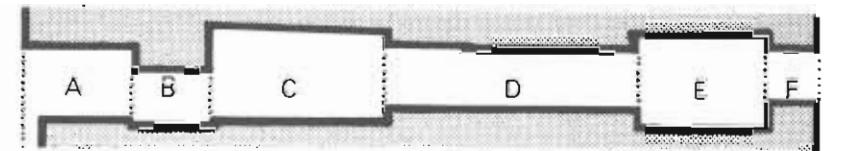

The monotony of linear space fig 3.322d is relieved by the creation of a series of sub-spaces fig 3.322e. Spaces C and D are reasonably dynamic. A, B, E and F are more static. The relative heights of the buildings may modify this. The individuality of the spaces may be further emphasised by change in architectural character.

All these are facets of the urban design framework, essential to creating good townscape.
 The policy therefore is as follows:

The Principles of Spatial Organisation (3.1)

New housing areas shall create a visually satisfactory environment, achieved by employing either the principles of:
 (i) buildings set within a dominant landscape of a character indigenous to Essex; or
 (ii) built forms set to satisfactorily enclose spaces of individual identity.

3.4

Design of Buildings within the Urban Framework

3.41

Regional Character

The principles outlined in the preceding section, governing urban places, may be observed in historic settlements anywhere in this country. However, the particular character of towns change, as one moves from one part of the country to another.

This is not because different urban principles are used, but it is due to the regional differences in the architecture forming the 'planes of the spaces', (although prevalence of certain types of space in particular localities may occur due to social, geographic and climatic influences).

The regional differences arose out of the need to build in the materials available in the locality, using details appropriate to those materials; transport of materials from one area to another being either very difficult or uneconomic.

Whilst a great variety of building styles was possible using the available materials, the result was invariably modern architecture of its time, and the limited palette gave a restful unity to the scheme.

Today regional character is still highly prized but transport does not limit the palette or encourage regional disciplines. If regional character is to be retained and unity given to urban places, *conscious choice*, not transport, will have to be the governing factor.

It is the intention of the Local Planning Authority, in new residential development, to foster local vernacular character where traditional forms of construction are proposed.

This should not prove to be too onerous on designers, as most new housing in the County uses traditional forms of construction: brick or rendered walls - tiled roofs - timber windows. It is really a question of which brick, which tile, which detail. Within the constraints of the Essex discipline, the good architect should be able to produce elegant 20th Century architecture.

The policy, therefore, is as follows:

Regional Character

To perpetuate the unique building character of the county and to re-establish local identity, development shall generally employ external materials which are sympathetic in colour and texture to the vernacular range of Essex materials.

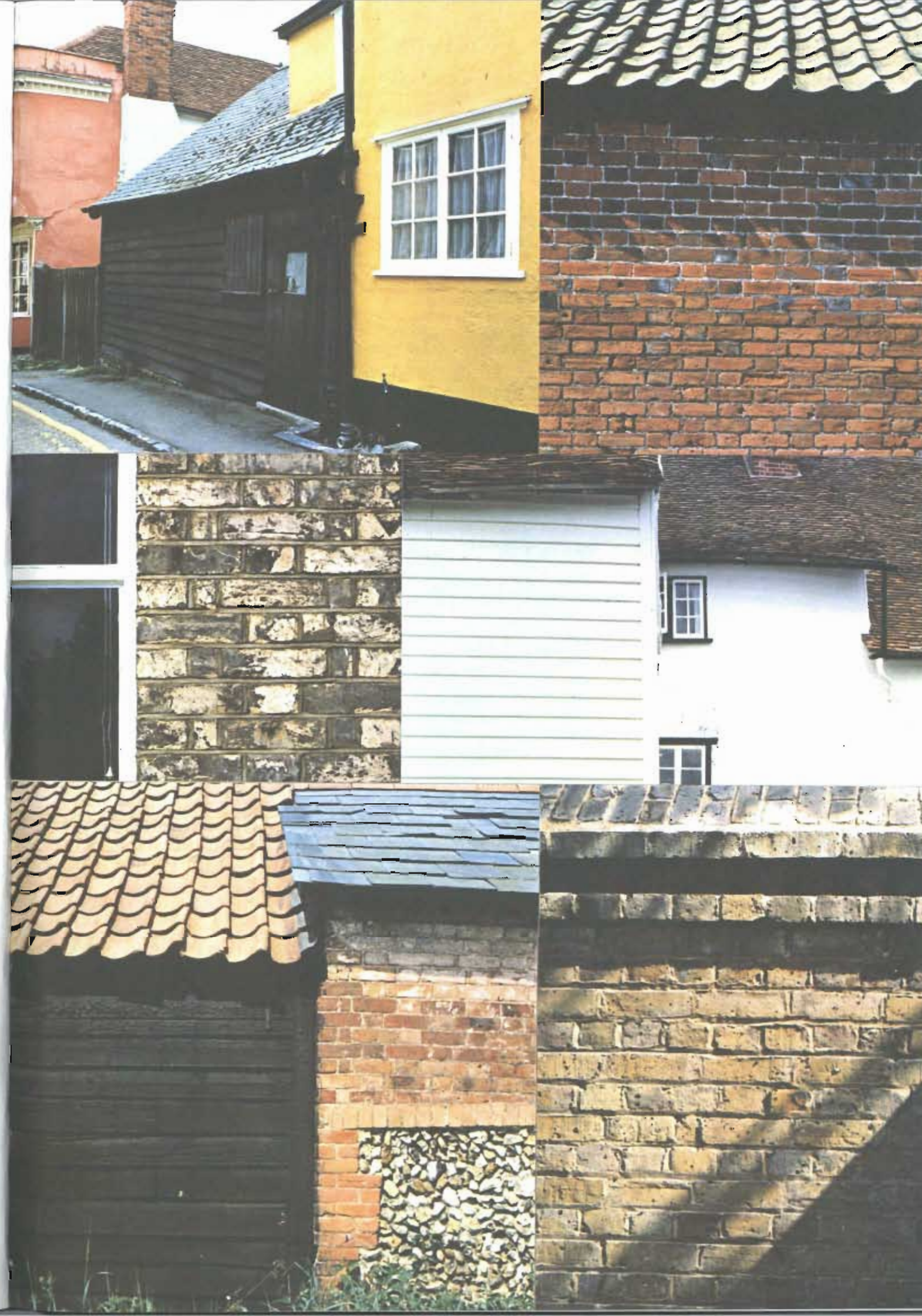

3.42

Local Materials

The traditional range of materials found in Essex is red, London stock and Gault bricks, rendering, white or black painted horizontal boarding and clay plain tiles.

Welsh slates are an accepted addition to the Essex scene, as they were the first natural materials introduced to extend the traditional range. They are acceptable provided they do not dominate the scene. Any further extension to this palette would fragment the scene and water down the local character.

In a particular locality, the choice of materials from this Essex palette should be those which would reinforce the traditional materials predominating in the area.

Where it is not possible to use these traditional materials, new products should be chosen which will be in harmony with traditional materials, examples being the use of blue/black asbestos cement instead of Welsh slates or the use of maintenance-free self-finish renderings in place of traditional painted render.

If development is to take place alongside existing 20th Century building which has not followed the Essex palette, extra care will have to be taken with materials. Neutral materials should be chosen from the range, for example, white rendering for walls, so that the house structures will look well in their own right and at the same time not conflict with what is there already.

To sum up, in those urbanised parts of Essex where the local building tradition has been diluted to such an extent that it hardly exists, the criteria may have to be relaxed insofar as local materials are concerned. Elsewhere the use of sympathetic material chosen to reinforce local identity will be required.

So far buildings have been regarded solely for the part they play in forming the larger urban composition or place. This is their prime 'townscape role', a matter of Urban design.

It is now proposed to consider the detail design of individual buildings. At this scale, one leaves the realm of townscape and enters the field of architecture. As it is the policy of the Local Planning Authority to refuse planning permission for buildings not well designed in themselves, it is only right for applicants to know what criteria will be used to determine if their buildings are or are not well designed.

Further, as only a very small proportion of building in Essex is designed by anyone with formal design training, the following section is an essential part of the design guide.

This section assumes a knowledge of the theory of design and employs words and phrases of common architectural usage; for example, 'unity' and 'visually determinate'. For those not familiar with this theory, some basic principles are set out in Appendix B.

The planning policy requires that:

Individual buildings shall be well designed in themselves and have adequate regard for their setting by:

- (i) the building being designed to form part of the larger composition of the area in which it is situated;
- (ii) the building using suitable external materials for the location in which it is situated;
- (iii) the volumes making up the block form of the building being proportioned and related to form a satisfactory composition;
- (iv) the external materials being used in a visually appropriate manner;
- (v) the fenestration being well proportioned and well related within the elevation and also being sympathetic to adjacent buildings;
- (vi) architectural detailing being used to reinforce the character required by the design and its location.

The preceding policy requirements are all based on the assumption that the aim in the design process must, once more, be to achieve a sense of harmony and repose, as it is the lack of the latter characteristics which is patently the cause of much dissatisfaction with the standard of recent housing.

However, it is recognised that architecture, viewed as an art form, involves the provocation of all emotional response - with much excellent architecture incorporating controlled areas of tension, within a harmonious visual framework, in order to heighten the emotional impact. Equally some apparently uncontrolled tension can give a sense of informality or of the picturesque, suggestive of human fallibility or change.

Therefore, the guidelines which follow are related to harmonious composition and will obviously be recognised as a point of controlled departure for the good designer in creating the architecture of today, whilst the unskilled will obviously find the guidelines useful in achieving simple building design with an acceptable level of repose.

- (i) the building being designed to form part of the larger composition of the area in which it is situated;
This aspect has already been covered in sections 3.31 to 3.322.

- (ii) the building using suitable external materials for the location in which it is situated;

This is a question of using materials which will reinforce local character and has been considered in sections 3.41 and 3.42.

- (iii) the volumes making up the block form of the building being proportioned and related to form a satisfactory composition;

To have a satisfactory form, the total composition of the volumes making up the building should:

- (i) be visually determinate (i.e. not be ambiguous);
- (ii) have unity.

Form

Traditionally the form of buildings has used a visual discipline which may be described as 'additive form'. That is, an irregular plan was covered by a series of separate forms added together.

The eye can immediately understand what is going on, it is 'visually determinate'. (fig 3.453a)

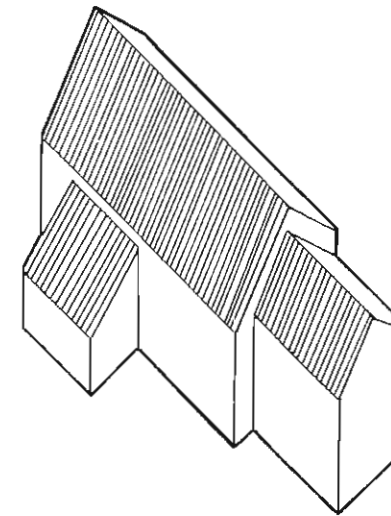

3.453a

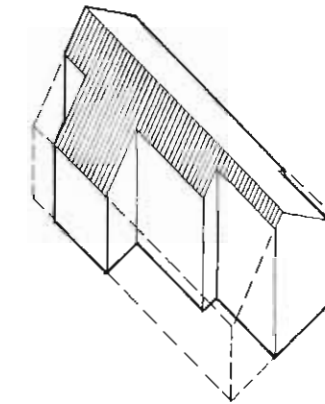

3.453b

Much recent building has unfortunately abandoned this approach and used 'subtractive form'.

Here, an irregular plan is visually covered by a single pitched volume whose span covers the extremities of the plan and from which pieces have been 'subtracted' to leave the desired plan outline. (fig 3.453b)

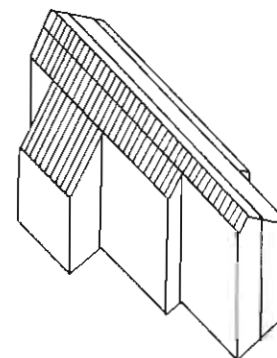

3.453c

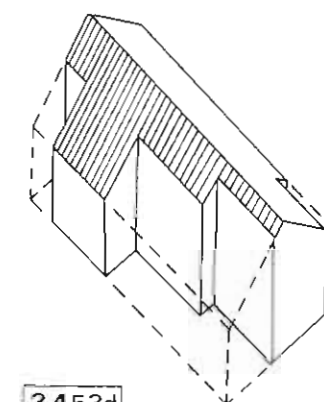

3.453d

This approach is rarely satisfactory; it is restless to the eye; which cannot decide whether the building is a series of smaller volumes added together (fig 3.453c) or one volume with pieces missing: (fig 3.453d) it is 'visually indeterminate'.

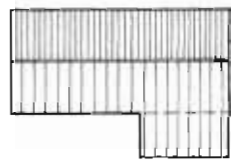
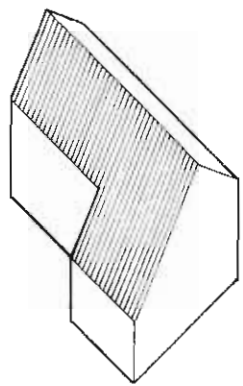

Additive Form but not obvious to the eye
3.453e

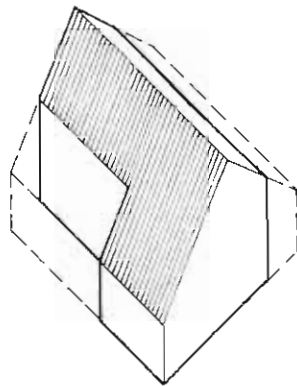

Could it be this?
3.453f

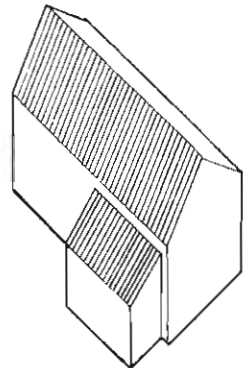

3.453g

Even 'additive form' buildings can be indeterminate if the forms are not articulated, that is if the forms are not related so that they appear to be separate. (Figs. 3.453e & f)
By 'articulating' the two volumes, it becomes obvious. (Fig. 3.453g)

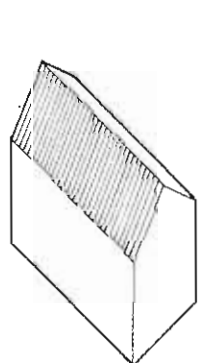

3.453h

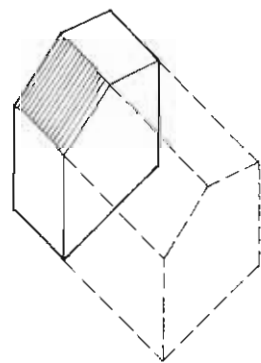

3.453i

With pitched roofed houses it is customary and structurally logical to span the roof across the narrowest plan dimension. (Fig. 3.453h)
Spanning the plan in the 'wrong' direction will introduce an element of ambiguity, in that the eye will try to 'invent' a larger building to re-create the familiar form. (Fig. 3.453i)

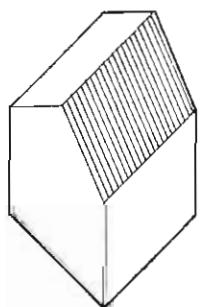

3.453j

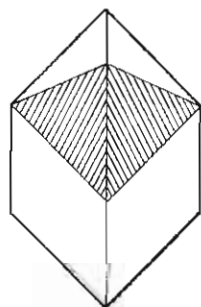
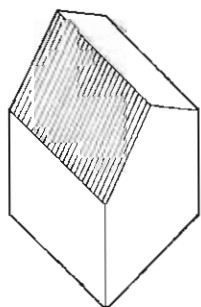

3.453k

The gabled pitch roof over a more or less square plan form will also introduce ambiguity, as the roof could span in either direction with an equal lack of logic. (Fig. 3.453j)

With the more or less square plan, the visually logical solution is the pyramid roof. (Fig. 3.453k)
Such a house plan is difficult to use as a townscape element, because its four elevations are of equal visual importance. It can, however, be used to advantage in low density 'landscape dominated' areas.

Unity

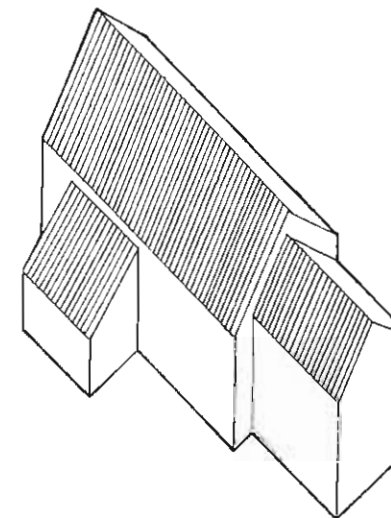

3.453m

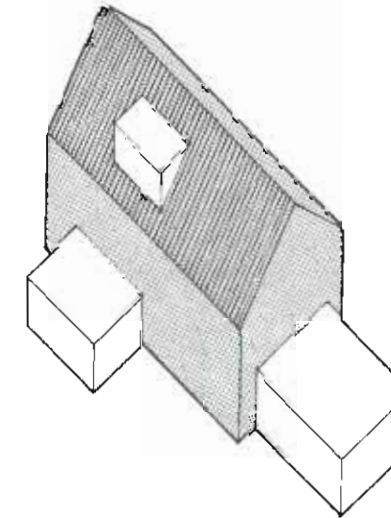

3.453n

The traditional 'additive form' building has visual unity, as the eye links the similar shapes of the pitched roofs. (The roofs all belong to the same family of forms.) fig. 3.453m
'Additive form' buildings mixing pitched and flat-topped shapes will be indeterminate. It is obvious what is going on but will lack unity; the eye will separate out the flat and pitched shapes. (Forms of different 'families') fig. 3.453n

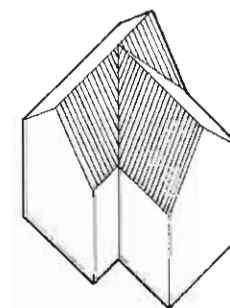

a duality of volumes

3.453p

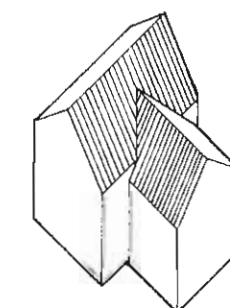

duality resolved

Where two volumes have equal, or nearly equal importance, a conflict arises. Neither volume is important enough to dominate the total composition. There will be a tendency towards a duality of form.

3.454

(iv) the external materials being used in a visually appropriate manner;

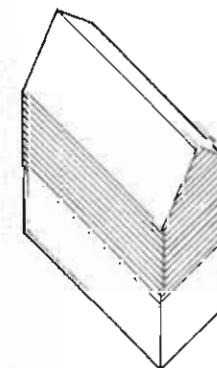

3.454 a

To prevent a restless effect, arbitrary changes of materials should be avoided. It is usually hard enough to organise the essential elements in an elevation without adding unnecessary complications. A logical change of structural system, for example from load bearing brick or block on the ground floor to light frame on the first, is a justification for a change of wall material.

The form of construction changes with the cladding. Although this is practical it appears visually ambiguous, as though the framing could be inserted anywhere.

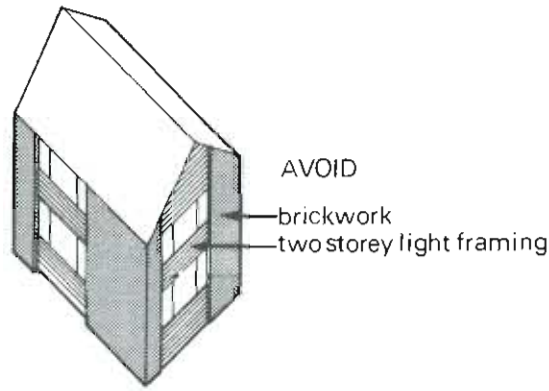

3.454b

The form of construction is entirely load-bearing, but the additional facing material is ambiguous, in that it suggests a change of structure.

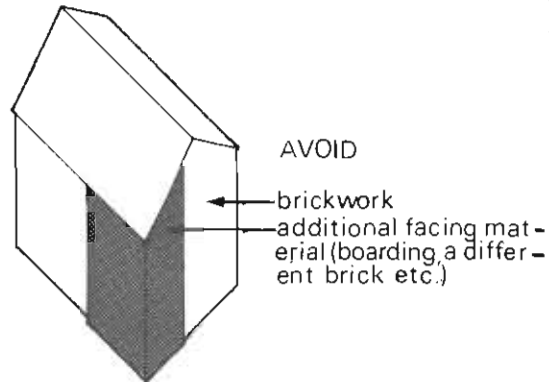

3.454c

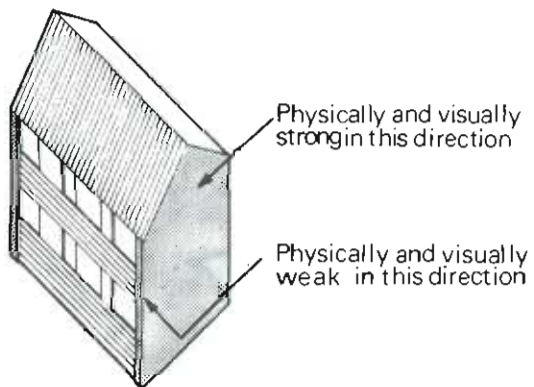

3.454d

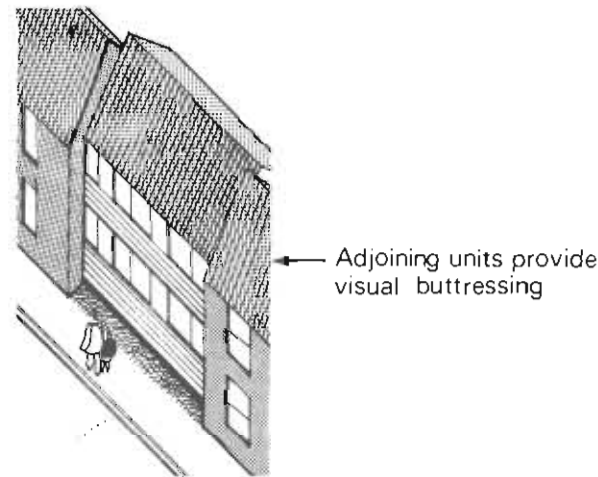

3.454e

Visually the cross-wall house can present problems if built in isolation, due to an apparent lack of stability in the plane parallel to the facade. If the cross wall unit is inserted between conventional units, this visual lack of stability is resolved.

3.455

(v) the fenestration being well proportioned and well related within the elevation and also being sympathetic to adjacent buildings:

Fenestration will have a marked impact on the final appearance of a building. The proportion and disposition of window and door openings will modify the unity, restful appearance, visual strength and balance of the elevations.

Unity of Elevations

The placing of openings can reinforce or destroy an otherwise unified composition. (Fig 3.455a)

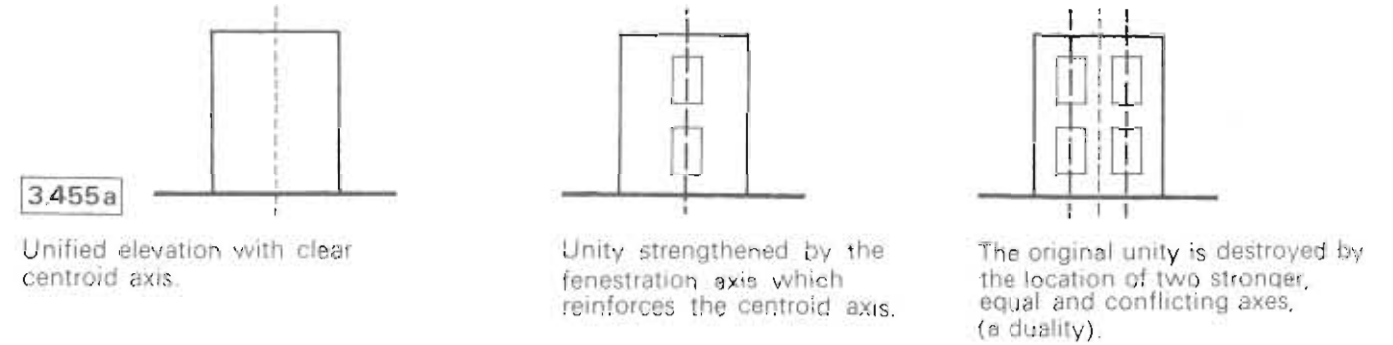

3.455a

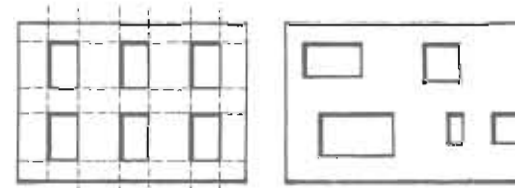

3.455b

To give repose, openings should be related in such a way as to allow the eye to move comfortably from one elevational element to the next without effort. Simple horizontal and vertical 'grid' relationships are the most obvious answer, also limiting the number of window types. (Fig 3.455b)

A restful effect Lack of repose

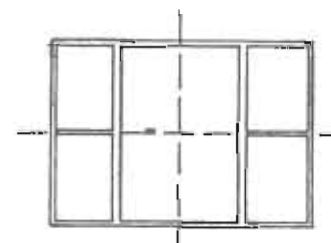

3.455c

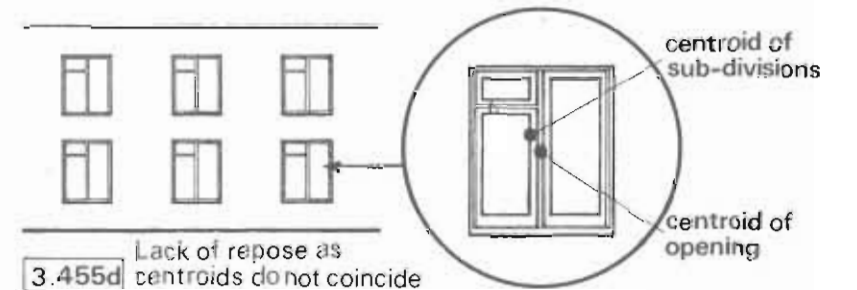

3.455d

Even if the openings themselves are in repose, harmony can be disturbed by the subdivisions of the openings. (Fig 3.455d)
Generally subdivisions will give a restful effect if they are disposed symmetrically about the horizontal and vertical axes of the openings. (Fig 3.455e)

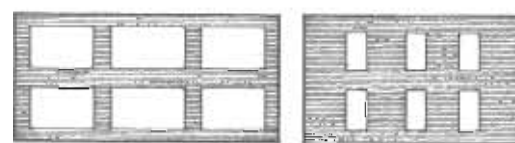

3.455e

Visual Strength

With loadbearing planes, over large or badly proportioned window openings can visually weaken the appearance of the elevation. (Fig 3.455ef)

Overlarge areas of glazing undermine the visual stability of this brick facade A dominant area of brickwork provides a visually stable facade

The form of construction changes with the cladding. Although this is practical it appears visually ambiguous, as though the framing could be inserted anywhere.

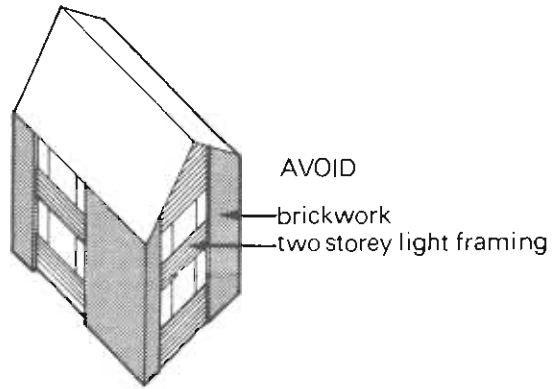

3.454b

The form of construction is entirely load-bearing, but the additional facing material is ambiguous, in that it suggests a change of structure.

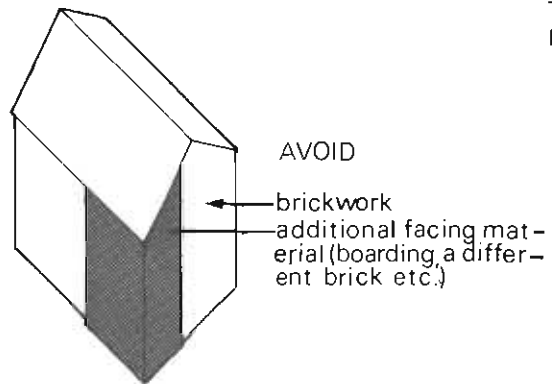

3.454c

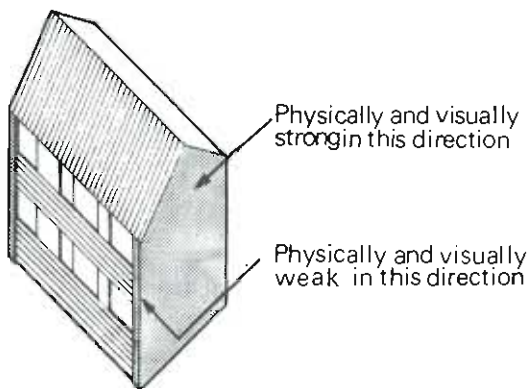

3.454d

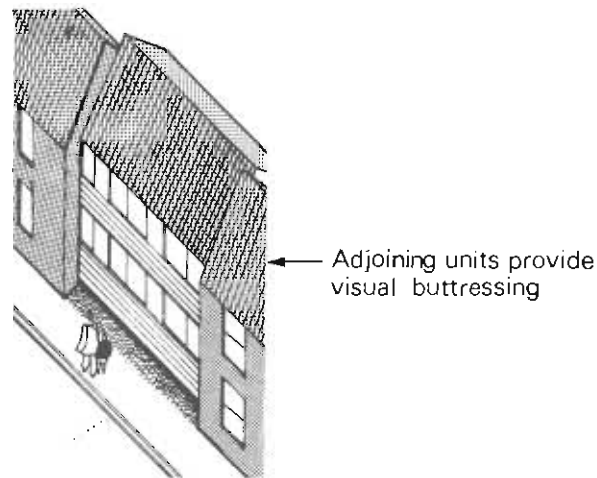

3.454e

Visually the cross-wall house can present problems if built in isolation, due to an apparent lack of stability in the plane parallel to the facade. If the cross wall unit is inserted between conventional units, this visual lack of stability is resolved.

3.455

(v) the fenestration being well proportioned and well related within the elevation and also being sympathetic to adjacent buildings;

Fenestration will have a marked impact on the final appearance of a building. The proportion and disposition of window and door openings will modify the unity, restful appearance, visual strength and balance of the elevations.

Unity of Elevations

The placing of openings can reinforce or destroy an otherwise unified composition. (Fig 3.455a)

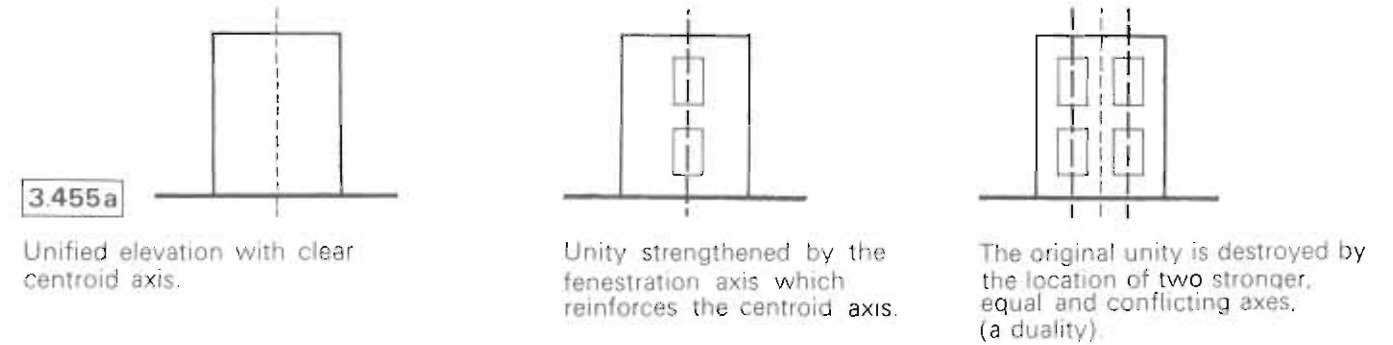

3.455a

Unified elevation with clear centroid axis.

Unity strengthened by the fenestration axis which reinforces the centroid axis.

The original unity is destroyed by the location of two stronger, equal and conflicting axes. (a duality).

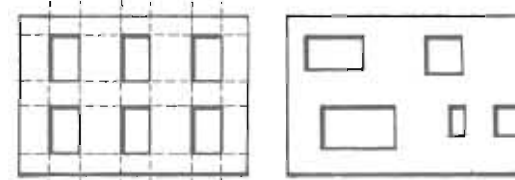

3.455b

A restful effect Lack of repose

To give repose, openings should be related in such a way as to allow the eye to move comfortably from one elevational element to the next without effort. Simple horizontal and vertical 'grid' relationships are the most obvious answer, also limiting the number of window types. (Fig 3.455b)

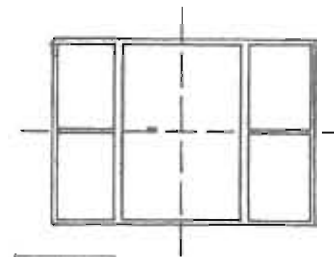

3.455c

A restful window pattern.

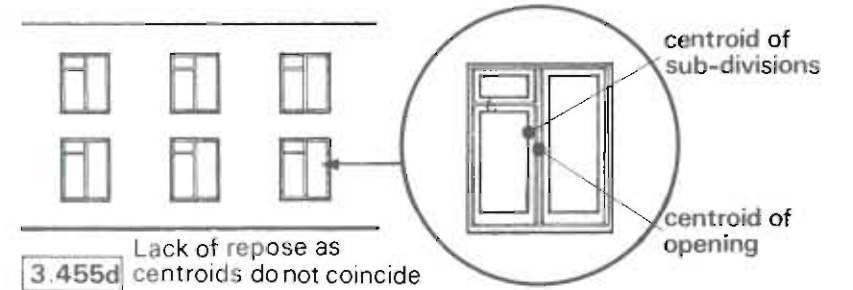

3.455d

Lack of repose as centroids do not coincide

Even if the openings themselves are in repose, harmony can be disturbed by the subdivisions of the openings. (Fig 3.455d)

Generally subdivisions will give a restful effect if they are disposed symmetrically about the horizontal and vertical axes of the openings. (Fig 3.455c)



3.455e

Overlarge areas of glazing undermine the visual stability of this brick facade

A dominant area of brickwork provides a visually stable facade

Visual Strength

With loadbearing planes, over large or badly proportioned window openings can visually weaken the appearance of the elevation. (Fig 3.455ef)

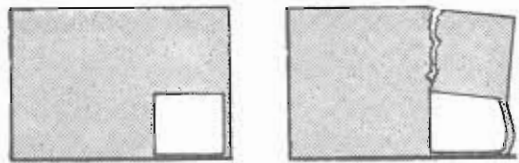

3.455f

Dominant window areas close to the edge of the elevation appear weak.

Balance

To be in repose all the visual forces in an elevation should be 'resolved', that is, the sum of all the forces in one direction should be balanced by the sum of all the forces in the other direction.

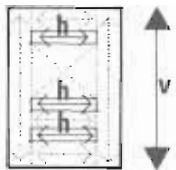

3.455g

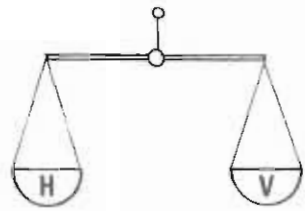

Forces resolved

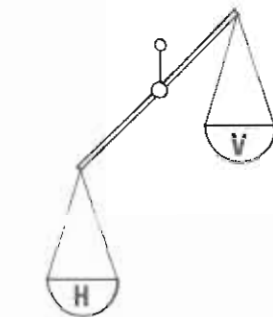
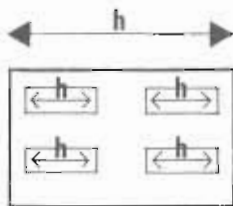

Forces unresolved

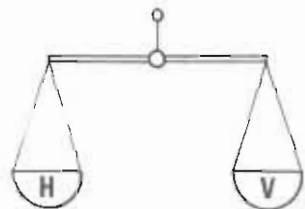
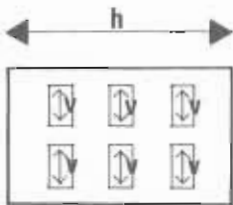

Forces resolved

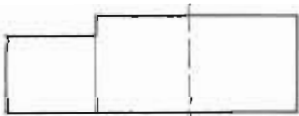

3.455h

Even if the forces within the elevation are resolved, fenestration must not destroy the overall balance of a composition. Plain volumes will balance about the centroid.

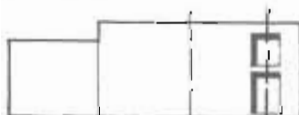

3.455 i

Openings may create a stronger axis which throws the composition out of balance (also tends to destroy unity due to conflict of axes).

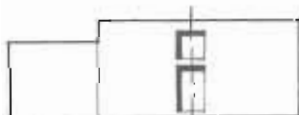

3.455 j

Ideally, fenestration should reinforce the centroid axis to avoid conflict and provide a natural focus to the composition.

(vi) architectural detailing being used to reinforce the character required by the design and its location.

(1) Details should not compromise good design decisions.

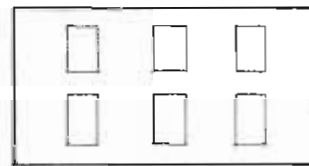

The elevation has a good relationship of window to wall areas, (giving a feeling of architectural strength) and also a good relationship between horizontal and vertical emphasis, (giving balance).

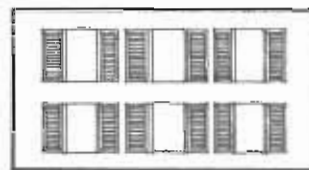

3.456a

Addition of shutters (which read as part of the window openings) destroys the window/wall relationship and the balance of horizontal and vertical emphasis.

(2) Details should not emphasise weak elements in a design.

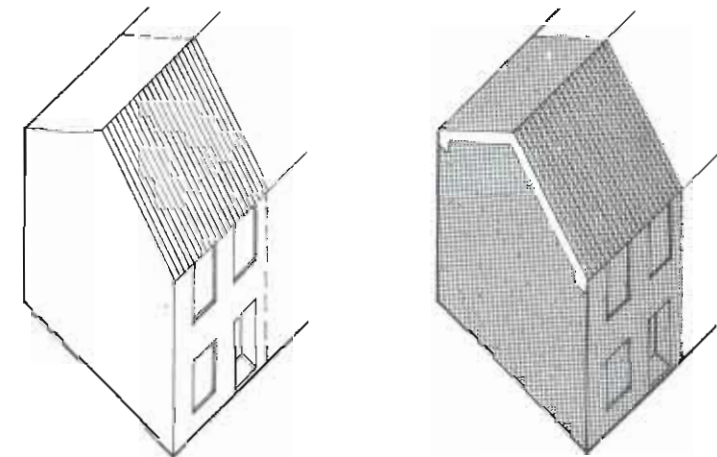

The deep gable end is as visually assertive as the main facade, producing a duality of emphasis.

Addition of bargeboards tends to emphasise this quality and underlines the poor proportions of the gable.

3.456b

(3) Details should be used to emphasise the qualities of a building and to reinforce its townscape role.

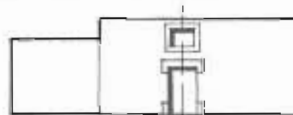

3.456c

Complexity of detailing used to reinforce the focal axis of the elevation.

(4) Detailing should be appropriate to the scale of the particular architectural element.

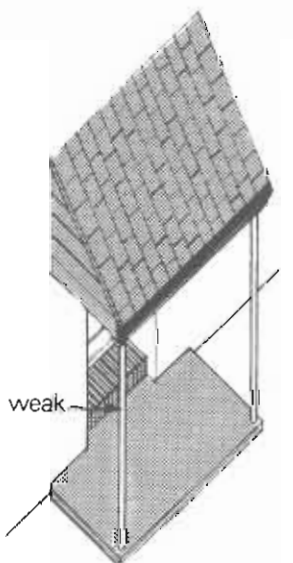

3.456d

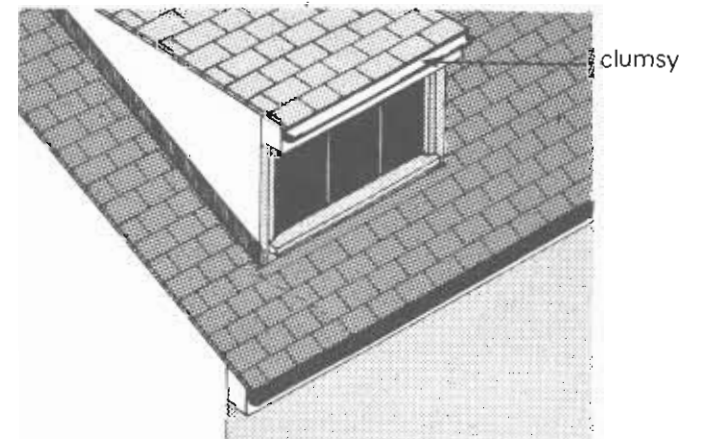



Housing design may be regarded as the production of a scheme which satisfies all the physical and visual requirements set by the designers brief.

This brief is divisible into three sections.

- (i) The clients requirements. Broadly the type of development he wishes to create and will take into account the relevant social, economic and marketing factors.
- (ii) The implied brief set by the characteristics of the particular site for development.
- (iii) The community brief. Any new development forms part of and affects the community. Therefore, it is reasonable for its members to expect certain things from the development. The planning authority as the representative of the community in such matters, provides this brief. In respect of housing, the brief is the new policy and contents of this document.

The design process is the systematic fusion of all the elements of this complex brief. It is not an easy task and certainly not one for an amateur. In fact, to get the best solution, it will be necessary for an architect to be employed from the earliest stage.

It will be the common experience of designers that certain elements of a housing brief will frequently appear to be in conflict, for example, townscape and highway requirements. Therefore, notes have been included in this section, to show some ways in which these recurrent problems can be overcome.

The notes are divided into three sections related to the three subdivisions of the brief mentioned above. They are not exhaustive and are included to stimulate thought and ingenuity, not produce stereotype solutions. If sufficient 'feedback' of information is available then it is intended to issue aspect papers on the current problems being experienced, along with advice on possible solutions.

Public sector housing and the cost yardstick control will undoubtedly be a major point of concern in this respect. The design guide has attempted to show how it is possible to get better value for money in housing area design without significantly affecting *total* costs. This exercise necessarily involves a change in the normal ratio of land, external works and construction costs per unit. Cost yardstick controls should encourage elemental savings to be made through efficient planning and design with the added incentive that this money could then be used to improve the general architectural character of a scheme.

The aspect notes are followed by case studies which illustrate some ways in which the requirements of the new design policy can be achieved.

COLOUR PLATES left :

above. Urban development: The Mews Court.

below. Informal arcadia

The primary requirements of a speculative developer would normally be :-

- (a) **The maximum number of a particular type of unit on the site**

This may conflict with :-

- 'Parker Morris' Space Standards.
- Requirements for space about buildings.
- Privacy.
- Space for highway requirements.
- The visual criteria of the design policy.

Solutions :-

- Reduce ground cover of dwellings, for example, by avoiding single storey houses, and also by building over car parking and/or garage space.
- Avoid wasting land by cutting out all useless space on the public side, for example, grass margins between footways and boundary walls and the useless setting back of buildings on urban schemes.
- Make maximum use of privacy by design.
- Make maximum use of the hierarchy of routes to avoid over-provision of roads.

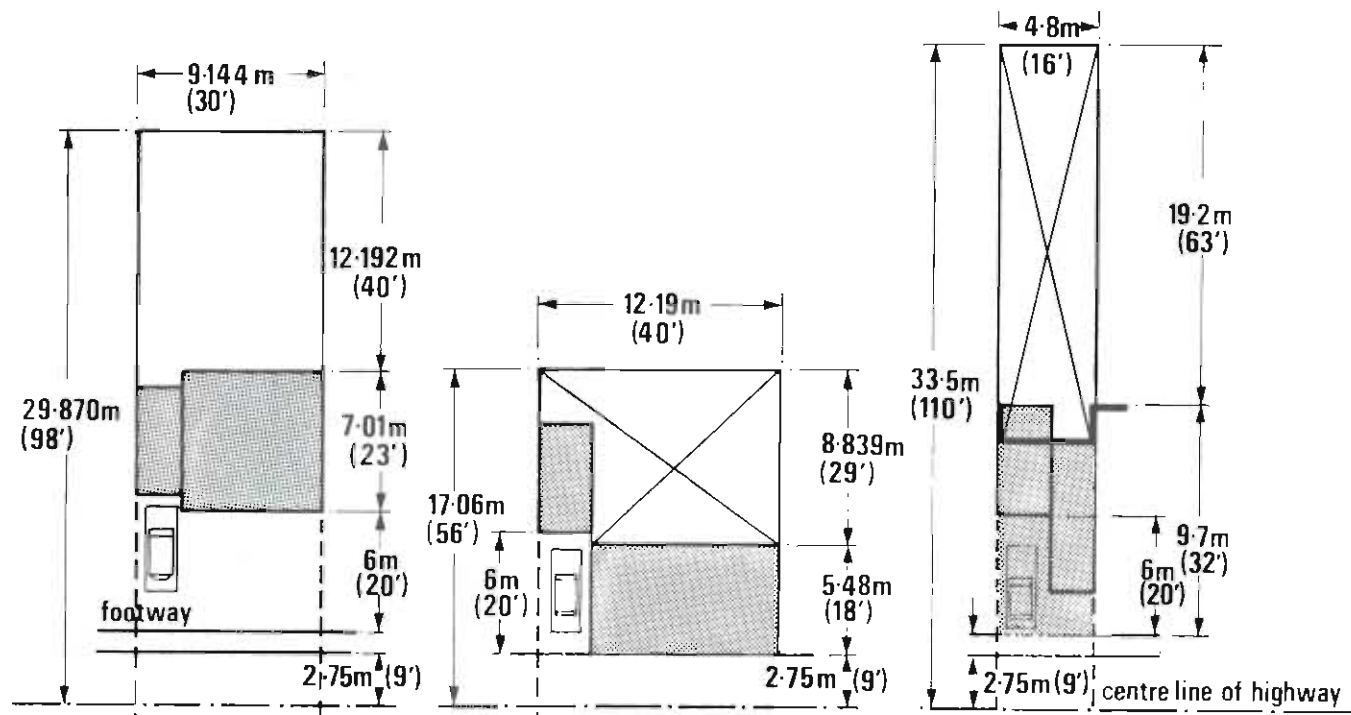

4.11 a Land use and Built form comparison.

4.11 b

4.11 c

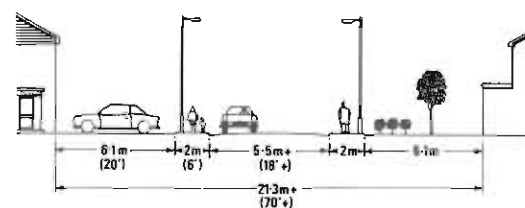

Fig.4.11a shows area of land required under the old standards for a two storey linked semi-detached house - 272sq m (2940sq ft)

Fig.4.11b shows area for a similar unit in mews court meeting the new criteria - 208sq m (2240sq ft)

Fig.4.11c shows area for a three storey in a street, meeting the new criteria - 160sq m (1760sq ft)

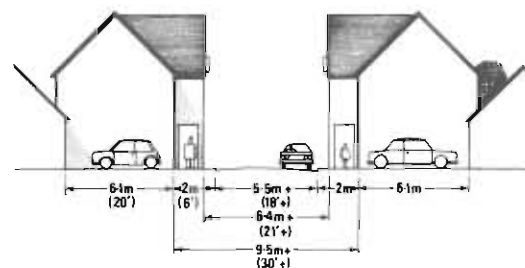

Fig.4.11d illustrates in section, possible land savings in the public zone

4.11 d

(b) **Minimum Constructional Costs**

May conflict with :-

- 'Parker Morris' Space Standards.
- Requirements for attractive public places and buildings.
- A high standard of highway design and construction.
- The clients own requirement for maximum selling price.

Solutions :-

- Reduce service runs and, therefore, cost per dwelling to a minimum by tight grouping in urban schemes.
- Reduce highway area per unit, for example, by use of mews courts and pedestrian only squares serviced from heads of cul-de-sac.

- Reduce the need for boundary walls to a minimum by avoiding public spaces abutting directly onto private gardens.
- Make substantial savings as indicated but avoid making savings which visually cheapen the product and produce second class public spaces.

(c) **Maximum sale price**

May conflict with clients own requirements for high density and low construction cost.

Solution :-

- Apart from providing well planned houses, provide a high quality of urban design in all the public areas, using good materials.
- Units cannot command their best price if they only make second class environments.

Apart from the engineering features, such as soil strengths, existing sewers, etc., all sites will have features which are either assets or disadvantages.

Obviously, the design process should take advantage of the assets and as far as possible overcome the disadvantages. Before the design process is begun a site survey and analysis should be prepared to identify all features and a copy eventually submitted with the Planning Application.

The first thing to establish is the *genius loci* of the surrounding area. If this special local character is attractive, then new development should draw something from it. If it is not, then it should establish its own character within the regional discipline.

The following are some aspects of *genius loci*.

DEGREE OF URBANITY, for example, hamlet, village, town or city character. New development should normally continue the tradition to keep a sense of place. Scale, intensity of development and degree of sophistication are dominant factors here, which will put certain constraints on density and dwelling type.

DOMINANCE OF CERTAIN MATERIALS within the Essex vernacular range gives a special character to some areas. The new should not upset this balance.

DOMINANCE OF LOCAL FORMS AND DETAILS may also give a sense of place. Where possible new development should reflect this tradition.

As well as the *genius loci*, most areas will have specific features which affect the site, for example, footpath links, or a view of a church. Again every effort should be made to exploit these features, to help in achieving a sense of place.

Features within the Site

HEAVILY TREED SITES. These are relatively rare in Essex. These are ideal for low density, landscape dominated 'arcadian' schemes and should not be wasted on medium density urban layouts.

SOME TREES ON THE SITE. In an urban layout the scheme should be worked around these to enhance the townscape. For example, where a square which is too big for the height of the enclosing buildings is essential, it should be sited round an existing big tree, so that the square becomes a satisfactorily enclosed circular linear space.

SLOPING SITES. Again relatively rare in Essex. Obviously, the temptation to design the layout as if the site were flat and then bend it to the contours, must be resisted.

Some advantages of changes in level :-

(a) Even with repetitious house types, it is possible to create apparent variety in groups of dwellings.

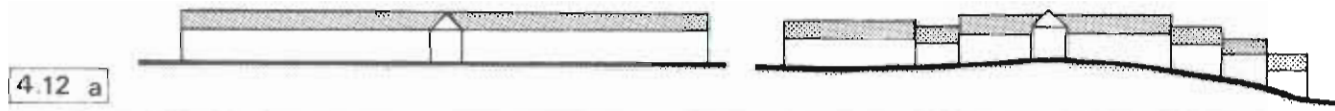

4.12 a

(b) Levels can be used to aid enclosure, an advantage where a proportion of single storey dwellings are required.

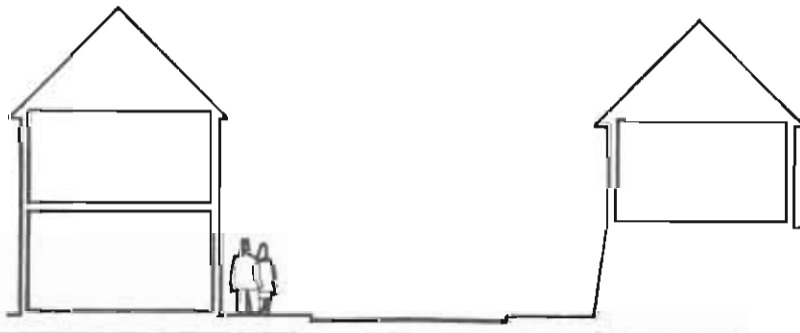

4.12 b

(c) Changes in level are useful in gaining privacy from the street.

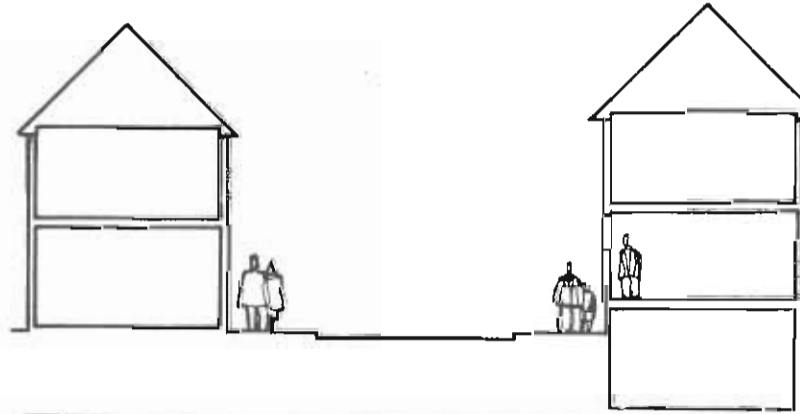

4.12 c

(d) or to incorporate the car

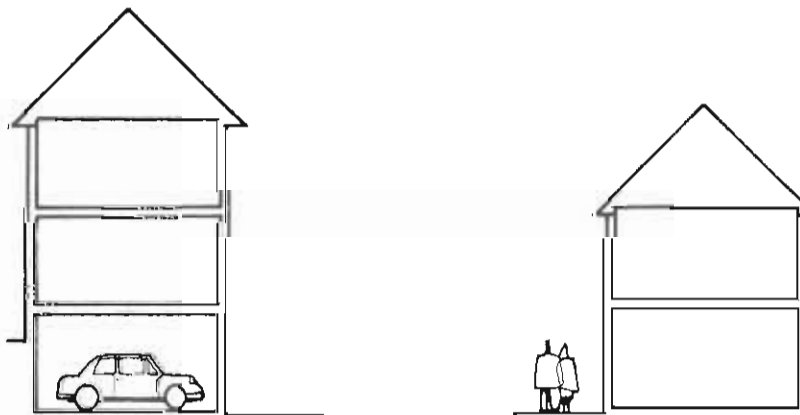

4.12 d

(e) or to emphasise vehicular pedestrian separation.

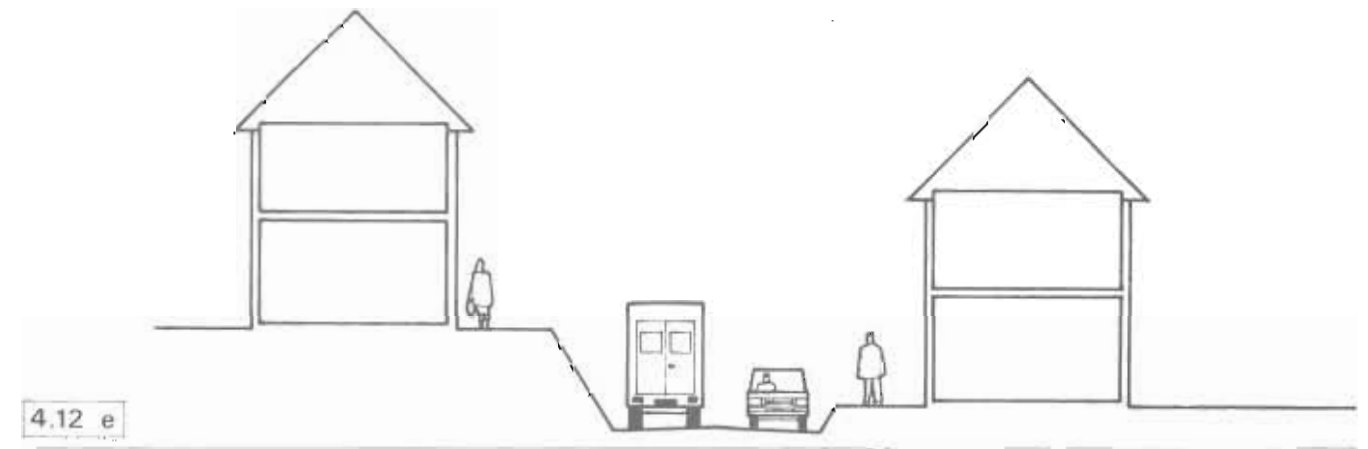

4.12 e

Edge Conditions

All site boundaries should be given special consideration. The boundaries will be of 2 types :-

- (1) Adjoining existing or future public spaces; for example, streets, parks or open landscape.
- (2) Adjoining existing or future private areas; e.g., gardens or storage yards.

There is little control by the community or developer over existing or new private areas, which may well be, or may become unsightly. Therefore, new public areas should not abut existing or future private areas and new private areas should not abut existing public areas.

Where this ideal cannot be achieved, above eye-level walls should be provided by the developer to screen private areas from public spaces.

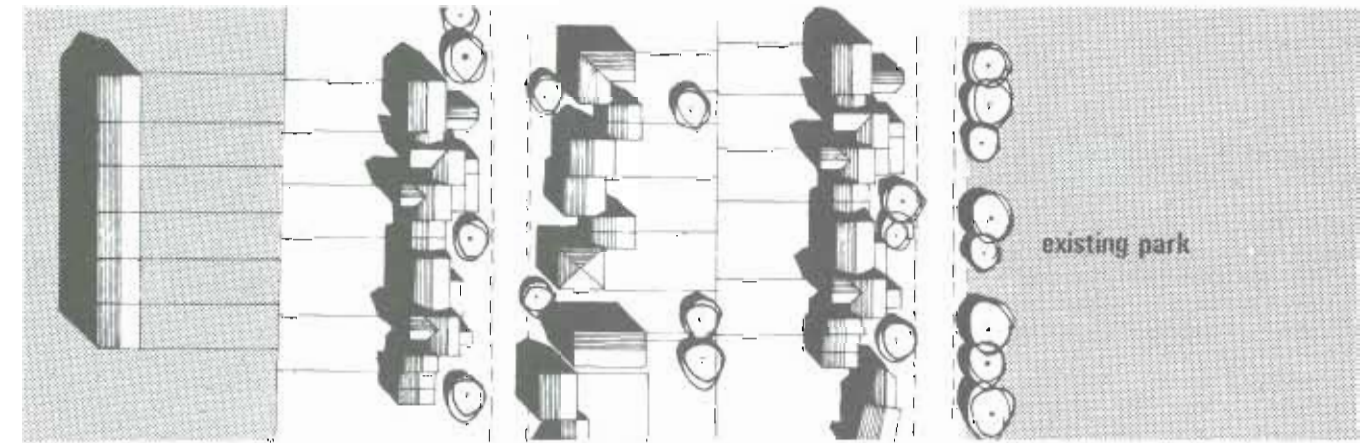

4.12 f This

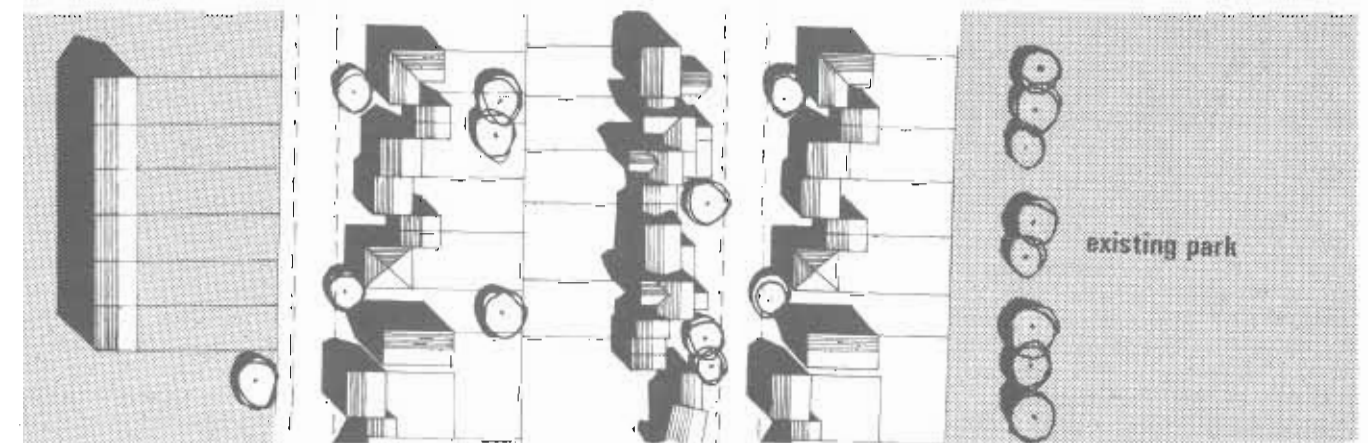

4.12 g Not this

It is sensible to exploit good views out of a site but these should not be provided at the expense of unsightly views in.

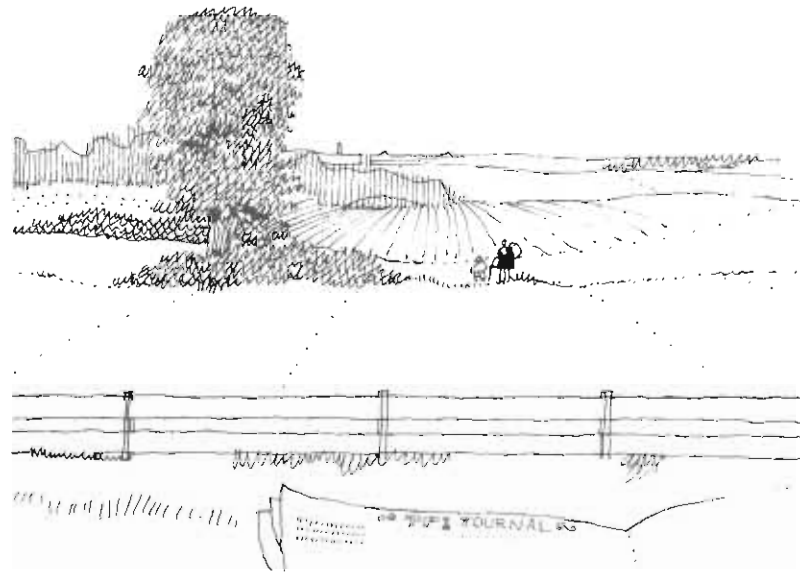

The householder can enjoy this view, but :-

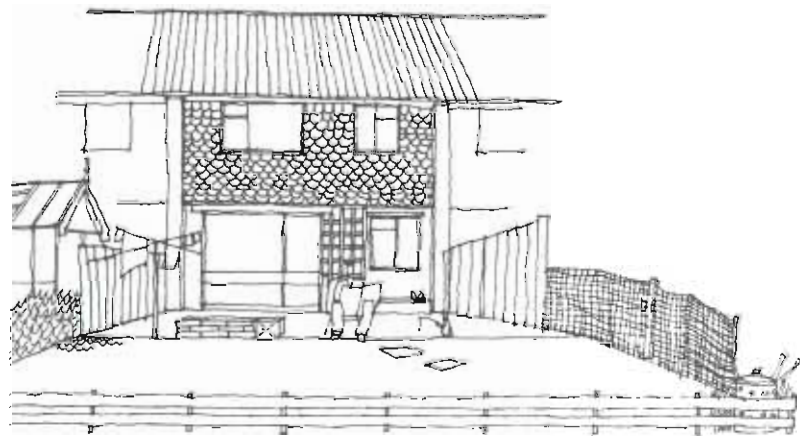

at the expense of the community having to endure this prospect.

4.13

Planning and design policy constraints

The third factor which relates to housing area design is planning standards and building controls.

These requirements can often appear to conflict with themselves or with the clients brief. Instance, road standards with townscape, high density low rise housing with preserved trees.

Some of these conflicts are capable of being resolved, others are not. It will be the job of the planner and the architect to attempt to ensure that land is developed at a density which satisfies both its visual and economic potential.

The most important aspect of the new design policy which needs to be understood is the principles of the rural and urban systems of spatial organisation. Here the designer will have to decide at the outset what *type of space* it is possible to create with each part of the scheme. For example, it is no use attempting to make an arcadian housing scheme if the ground cover by buildings is such as to prevent the landscape being the dominant element. Alternatively, certain roads will be so wide, that given normal domestic building heights, they will be impossible to enclose satisfactorily, and thus make townscape. Tree planting will obviously be needed to modify such spaces. Equally, it is important that sufficient building bulk, or density of development is permitted so as it is possible to satisfactorily enclose urban spaces and thus avoid the main pitfall of suburbia.

In this latter respect, the motor vehicle will be the most disruptive

single element in the creation of attractive places. The vehicle tends to impose a scale, due to its size and speed, which is not related to the human being. For example, the height of buildings will be related to man but the widths, lengths and changes in direction of linear spaces will tend to be related to the car, which is a larger and faster object.

It would appear that from the safety and visual aspects the solution lies in the provision of pedestrian spaces related to man and separate vehicle spaces related to the car. The drawback to this principle is loss of density. Schemes which have attempted this solution have either tried to retain 'dual purpose space' densities by, offering poor vehicle accessibility to individual dwellings, or encroaching on the areas of private open space.

Another disruptive feature of cars in housing is their dominance when parked. The dominance is still very noticeable even at the level of individual garages, where the garage door, due to its size, will dominate over the more important main entrance to the dwelling...

To overcome these problems as far as possible, the case studies employ the following ideas :-

(a) By employing a hierarchy of routes, the use of 'dual purpose' spaces will be acceptable for most housing. Fast moving local traffic will be kept out of residential streets and use landscaped roads related to speeds and flow. Thus in the residential streets themselves, there will be small flows and low speeds, enabling a better relationship to the pedestrian scale due to narrower carriageways and tighter curves.

(b) Where segregated spaces are suggested, they avoid waste of land by being:

- (i) Short linear spaces just wide enough for the pedestrian, which are, therefore, enclosed by low single storey building.
- (ii) Static spaces which provide usefully shaped pieces of public space and by their centralised nature allow a considerable number of dwellings to be grouped near vehicle access points. Also cars are parked and garaged in otherwise unusable pockets of land, bounded by back gardens, in the internal angles of the squares.

(c) The impact of parked cars is reduced whenever possible by siting them between or under buildings, or in areas of enclosed land away from main routes.

4.14

Some techniques of Landscape Dominated Design

Land economics may well dictate that low density housing will be the exception rather than the rule in new residential areas. In order to ensure that the landscape dominates the housing, and that pressure for removal of trees is reduced, the Planning Authority may well require that areas of low density development are located on sites where tree cover is extensive.

Layouts on this type of site should be designed on the 'informal' or 'picturesque' principle. Where developers wish to provide areas of low density housing on relatively tree-less sites, the problem of establishing immediately a landscape dominated development is difficult to overcome.

4.141

Informal Arcadia

The following practice notes describe some ways in which the principles set out in section 3.22 can be effectively carried out. The case study 4.23 shows a typical example.

Roads

To achieve informal arcadia or the picturesque and to maintain the landscape as the dominating feature with buildings only seen as surprise features set within that landscape, it is essential that the roads should be designed to be as unobtrusive as possible. They should follow the contours of the site, curve to avoid monotony, and penetrate only as far as is necessary leaving areas to be served by narrower private drives. The levels of the road surface should be adjusted to allow sufficient surplus material for forming earth banks; (see fig. 414a) whether the road formation is in reinforced concrete, or in flexible construction the surface finish should be with bituminous materi-

al, as the dark colour will reduce the visual impact of the road. In time, when re-surfacing is necessary a gravel tarsprayed finish will help to produce a more informal appearance. The use of granite kerbs will also help to achieve the same effect, as they are darker than concrete, and above all irregular in shape.

Footpaths

Footpaths are an extension of the visual width of the road, they should be surfaced in cold asphalt and can with advantage be edged in black concrete edging, stock brickwork or setts, when available. By designing a layout incorporating private drives (type 6 roads) serving small groups of houses, considerable lengths of footpath can be omitted.

On certain sites lengths of footpath may be routed away from the carriageway to avoid trees; however, mature trees 'retained' in this way, sandwiched between the edge of the carriageway and the footpath frequently die due to root damage, (they may also become unsafe). 3.00m should be considered as a minimum distance from the edge of the carriageway to the base of a mature tree to give the tree a reasonable chance of survival.

The houses

Houses should be carefully located amongst the trees in order that glimpses of buildings appear along the road but never at the expense of the landscape. The actual density of development will be set, not only by the number of trees worthy of preservation, but also by their disposition, the site shape, access points etc. It is however unlikely that the visual effect of informal arcadia can be achieved at a density above 3 to 4 houses per acre. On Essex clay soils, a development of this type set amongst many trees will need specialist foundation design to avoid possible differential settlement, and an excuse for the destruction of the trees. It is essential that the houses are designed and fenestrated to make the best use of the open spaces and also that there are adequate gutters and rain water pipes easily cleaned of leaves and pine needles in the autumn.

Privacy

Seclusion is vital to arcadia, and designing for privacy will also reduce to a minimum the 'public zone' which will virtually become the area of the roads and footpaths; even the access space can become part of the 'private zone' by the use of hedges and gated entrances.

Hedges cannot be established overnight, and therefore the formation of earth banks at the back of the footpath approximately 1m (3ft. 3in.) in height will enable the hedges to be planted with greater initial effect and establish the principle behind the scheme with greater permanence. Drive entrances are cut through the banking with gates recessed a minimum of 2.100m. (6ft. 11in.) from the back of the footpath. Visibility at the entrance should comply with Fig. 2.323c. Garden boundaries should also be basically in hedges and shrubs, although 2m (6ft. 7in.) high close boarded fencing may be needed initially for privacy.

Plant material

The existing large trees should provide a considerable canopy on which the development will rely for its initial effect. With the front hedges established, individual owner's flowering trees should not upset the overall landscape appearance.

For details of hedge planting see "Arcadia planting guide" section 4.143.

Services

Services can have a considerable effect on existing trees, a minimum distance of 3m (10ft.) should be allowed between drainage and service trenches and trees that are to be retained. These trenches should be grouped if necessary and routed to one side of the tree only. Detailed planning applications on tree dominated sites should in-

clude a schematic drainage and services layout in order that the full implications of the development can be assessed.

4.142

Formal Arcadia

Many of the notes relating to Informal Arcadia - e.g. the detailing of footpaths, roads and banks also apply to the formal situation. Other points are examined below based on an analysis of the plan and section showing a typical layout. (Fig. 4.142a)

The Public Zone

- (i) Verge. A 3.200m (10ft. 6in.) (minimum) verge is shown but may vary depending on the tree species to be planted and the services to be accommodated. The ground surface should be grassed or if desired suitable shrubs may be used for ground cover - these should basically have dark green foliage, exotic flowering shrubs should generally be avoided. (See section 4.143 for details of suitable types).
- (ii) 'The avenue' is shown planted with large deciduous trees at approximately 6m (20ft.) centres. (For species see 4.413) exact regularity of centres is not necessary and can be altered to suit drive entrances. Staggering the centres on each side of the road allows better development of the crowns of the trees. The local authority will normally maintain these trees and sympathetic treatment is essential, inevitably thinning out will be necessary later and lower branches will need removal to maintain the 5.100m (16ft. 6in.) clearance above the carriageway, (see Note 3).
In order to establish the principle of the avenue initially and to reduce the risk of vandalism, trees should be in the region of 3m (10ft.) high when planted and properly staked and tied.
- (iii) On minor footpaths in arcadian layouts the footpath width may be reduced to 1.500m (4ft. 9in.) where a grass verge is provided.

Front and side gardens

This area between the footpath and the house, although in private ownership, should nevertheless be treated in 'landscape' rather than 'gardening' terms, as it affects the overall appearance of the public space.

- (i) The banking principle is shown in the section and hedges are established on these banks and between front gardens. A guide to the suitable species is included in section 4.143. The use of dark evergreen hedges (particularly the holly and yew) is particularly successful beneath the more colourful tree planting in the front garden.
- (ii) THE FRONT GARDENS: a large area is of necessity covered by driveways and turning areas. It is therefore essential to choose surfacing materials as sympathetic to arcadia as possible, ideally gravel rolled into a hoggin base set between timber or stock brick edges is visually the best material. However at the point where the drive becomes an 'adopted' crossover, construction and surfacing must comply with adoption standards. The planting is now within the personal control of house owners and the choice of trees and shrubs is not so critical provided the hedges are established as above. While the *occasional* flowering tree can be successfully introduced, it is essential that the greens should remain dominant, from the black olive greens of the holly to the pale silver and yellow greens of the willows and birches. Flowering trees and shrubs should provide seasonal interest, not destroy the unity of the whole. Red or copper leaved trees and shrubs should be used very sparingly. Their value as occasional contrast is lost if too many are used.

Formal Arcadia

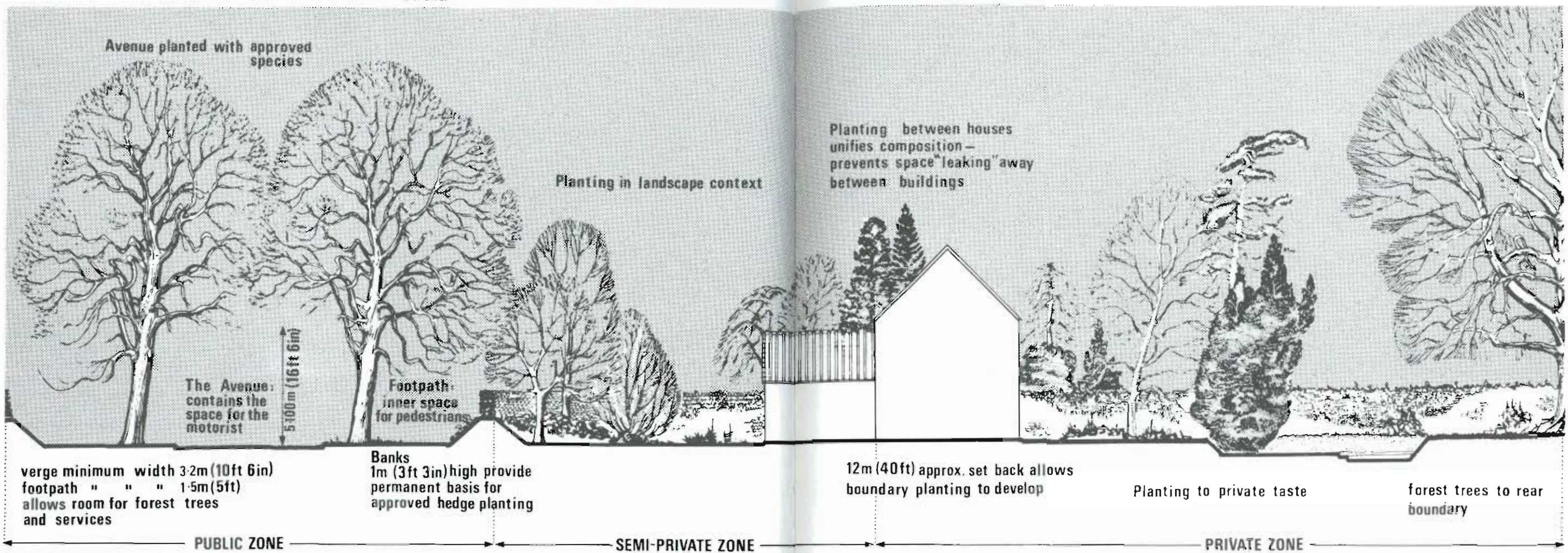

4.142 a Section

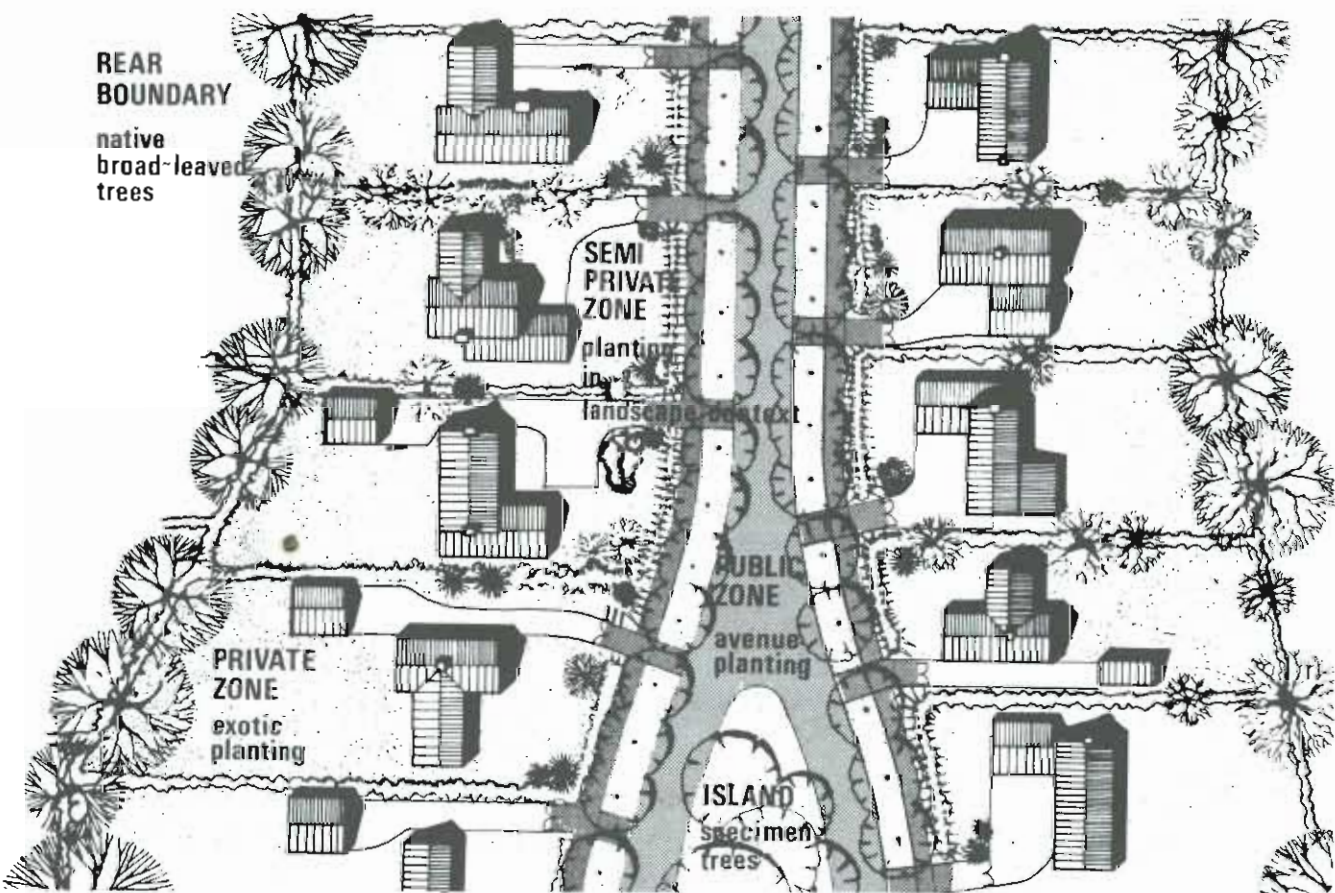

4.142 b Plan

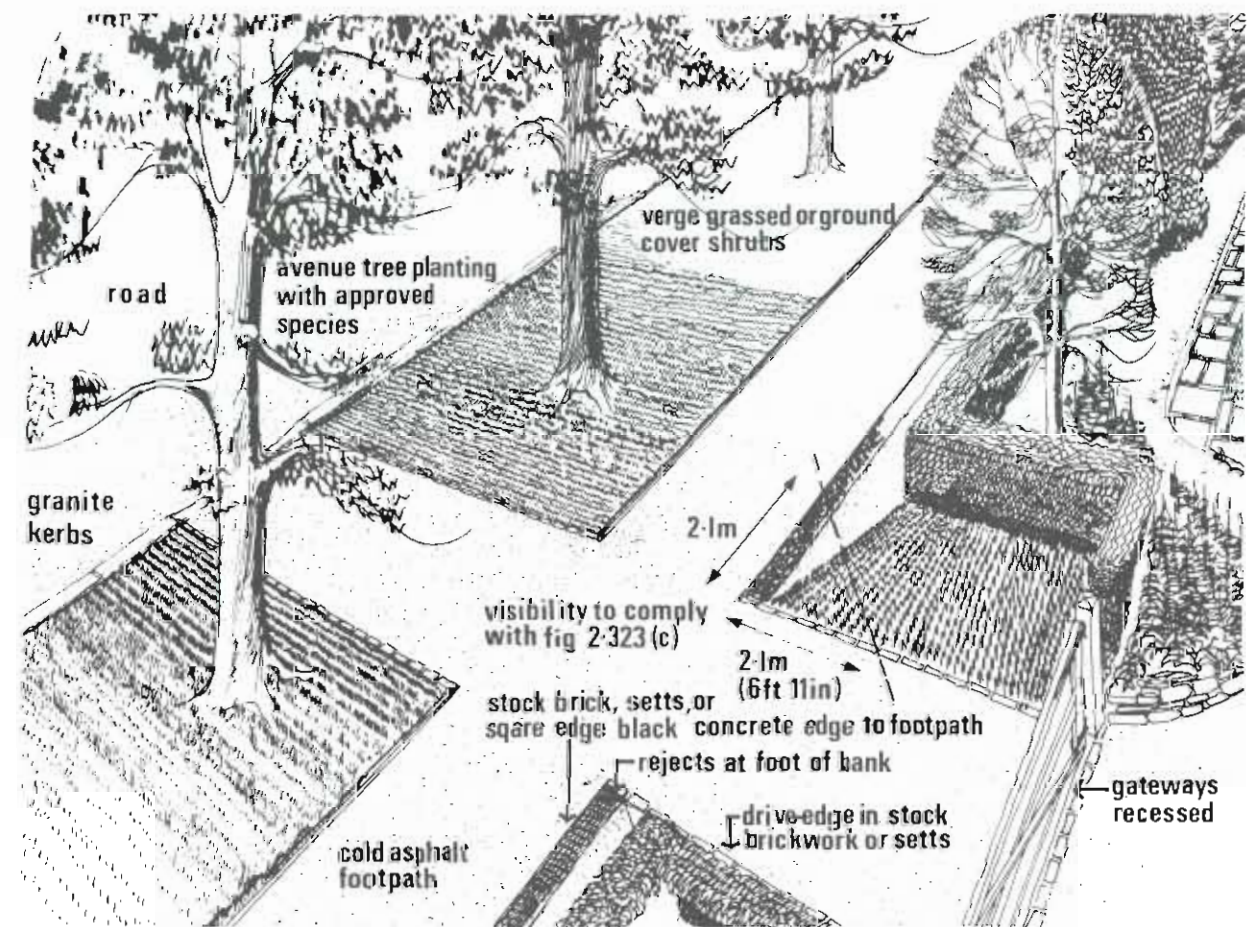

4.142 c Perspective

The private zone

Here the house owner can display all his virtuosity for exotic tree, shrub and flower planting without landscape problems, provided that the rear boundary is kept for planting forest trees which will form the unifying backcloth to the development. With rear gardens of 20m (65ft.) to 30m (100ft.) in depth, there is room for large trees to develop (see section 4.143).

Plant material

As has been indicated, the selection of the right tree and shrub species, appropriate in scale and colour to their place, can be as important to the success of Arcadia as the detailing of buildings and the floorscape between them. Trees and shrubs suitable for 'private space' often appear mean and inappropriate when planted in public places.

4.143

A Guide to Planting for Arcadia

Planting in verge (ground cover)

Euonymus fortunei radicans
Pachysandra terminalis
Hedera colchica and *Hedera canariensis* (species of ivy useful also for banks)
Cotoneaster microphyllus and *dammeri*
Arctostaphylos nevandensis
Oxalis oregana
Hypericum calycinum (St. John's Wort).

Avenue Planting

Tilia petiolaris (Silver Lime)
Tilia platyphyllos—rubra (Red Twigged Lime)
Castanea sativa (Spanish Chestnut)
Platanus acerifolia (London Plane)
Quercus cerris (Turkey Oak)
Robinia pseudoacacia (False Acacia)
Acer saccharinum (Silver Maple)
Fagus sylvatica (Beech)
Catalpa bignonioides (Indian Bean)
Aesculus hippocastanum (Horse Chestnut)

Hedges to front boundary

Ilex (Holly)
Taxus baccata (Yew)
Prunus lusitanica (Laurel)
Ligustrum ovalifolium (Oval-leaved Privet)
Fagus sylvatica (Beech)
Carpinus betulus (Hornbeam)
Crataegus monogyna (Quickthorn) (mixed with Beach, Hornbeam and Rose or Privet)
Corylus (Hazel)

Rear boundary

Quercus robur (English Oak)
Quercus ilex (Holm Oak)
Quercus cerris (Turkey Oak)
Alnus glutinosa (Alder)
Fraxinus excelsior (Ash)
Carpinus betulus (Hornbeam)
Fagus sylvatica (Beech)
Aesculus hippocastanum (Horse Chestnut)
Tilia platyphyllos—rubra (Red twigged lime)
Acer pseudoplatanus (Sycamore)
Pinus sylvestris (Scots Pine)

4.15

Some techniques of Urban Design

Two major problems will be encountered when designing new urban residential areas. One, the problems of monotony created by the present market for a limited range of dwelling types. Two, the rigid constraints on layout, imposed by requirements for vehicle accessibility. The practice notes offer some suggestions to help overcome these problems and other obstacles which hinder the creation of good townscape.

A limited range of building types creates monotony for two reasons. First, as the range is normally single, two or three storey, there is a severe limit to the width of spaces which can be satisfactorily enclosed. Secondly, the uniformity of plan size and type results in a lack of architectural variety in the buildings themselves.

To overcome lack of height, the designer has to discipline himself to limiting the maximum size of public spaces and achieve as much variety as possible within this upper limit.

In order to provide the maximum architectural variety, a series of house types which have components, for example, garages and porches, which 'clip on' in a number of different ways, will have advantages; as the permutations of all possible groupings will then be quite extensive. (the elevations in section 4.54 illustrate this approach)

4.151

Roads and street architecture

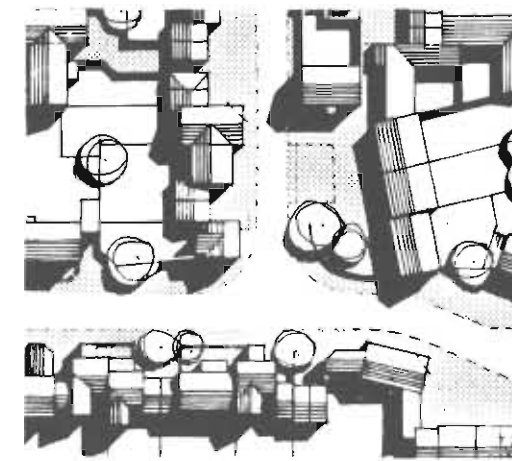

4.151 a

With two storey housing, linear spaces should not be wider than about 12m (40 ft.) and static spaces 22m (75 ft.), if a reasonable degree of enclosure is to be achieved. In a linear street the normal highway will take up about 10m (33 ft.) of this space. Therefore, buildings will have to be close to the back of the footpath, with car parking spaces between or under dwellings; not in front.

At road junctions, the highway width, kerb radii and sight splays, will tend to open up the townscape. The opening up can be incorporated into a static space.

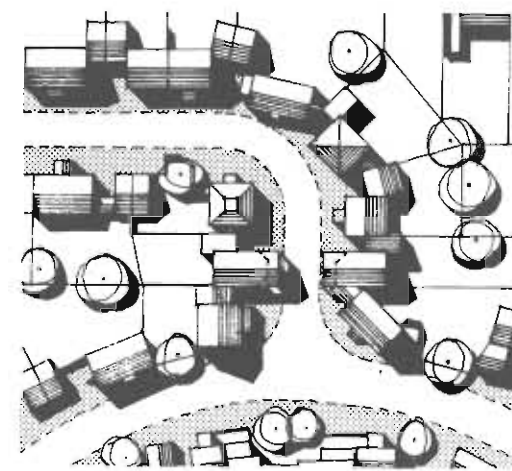







4.151 b

Or the aim can be to minimise the impact by :-

- (i) siting junctions on the outside of bends to reduce the space needed for sight splays but ensuring that traffic turning right from the main road has adequate visibility of approaching traffic.
- (ii) building over the footways at first floor level to visually narrow the highway.
- (iii) closing the vista by a quick bend in the road.

A change of direction by straights, connected by the sharpest permissible bend (for the type of road), reduces land needed for the forward visibility curve; compared with a long easy bend. This is due to the short visibility distances needed on tight curves. (See graphs: section 2.322 note 9)

Even with this approach it will be difficult to get contrast by providing some really strongly enclosed spaces, if only the type 2, 3, 4A and 4B roads are used. However, the type 5 Mews Court offers scope for contrast. The highway need only be 5.500m. (18 ft.), no radii are required at junctions, and sight splays are usually incorporated within the highway. In these situations the buildings will be seen at close range. Therefore, the quality of materials and detailing must be high. The concept of the mews court is to make possible the creation of high quality, intimate scale, urban places, NOT SUBURBIA WITH THE FOOTWAYS LEFT OUT.

- KEY**
-  Viewpoint of Fig.4.151d
 - P** Parking
 - G** Garage
 - ▲** Front door
 -  Main prospect
 -  2m. wall
 -  Minimum highway area required in court
 -  Private zone
 -  Public zone
 -  Adopted highway in public zone

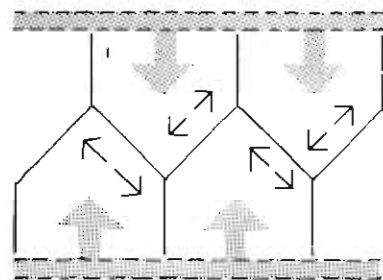
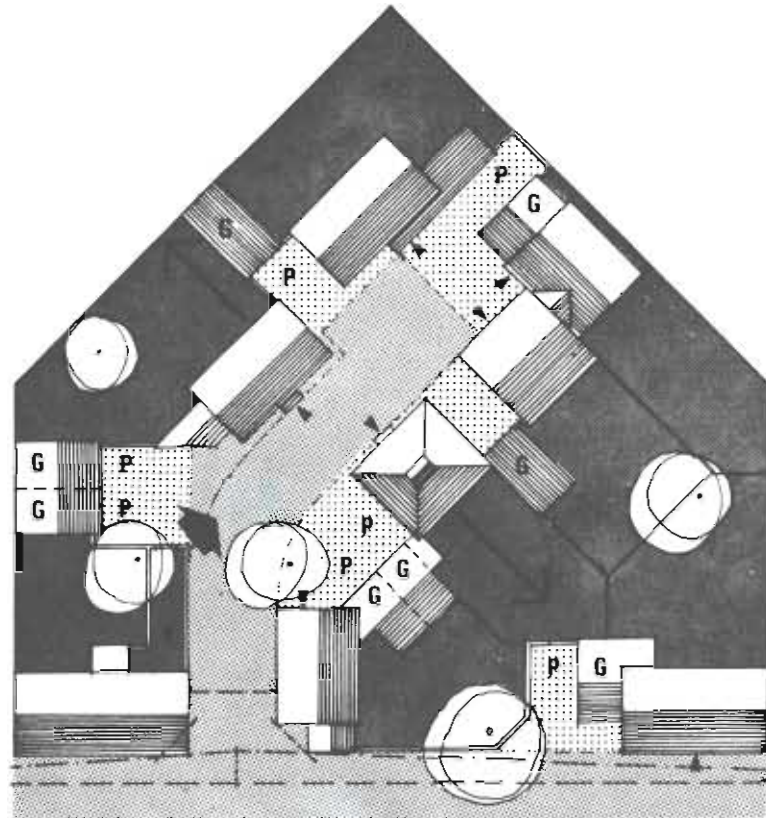







Considerable spatial variety is possible within this chevron shaped site, which, grouped as shown provides a compact layout avoiding back to back overlooking. N.B. The rigid grid is only diagrammatic, on actual sites the principle can be maintained but using a more informal layout.

4.151 c Mews court (chevron)



4.151 d Sketch of mews court (see Fig.4.151c)

- KEY**
- P** Parking
 - G** Garage
 - ▲** Front door
 -  Main prospect
 -  2m. wall
 -  Minimum highway area required in court
 -  Private zone
 -  Public zone
 -  Adopted highway in public zone

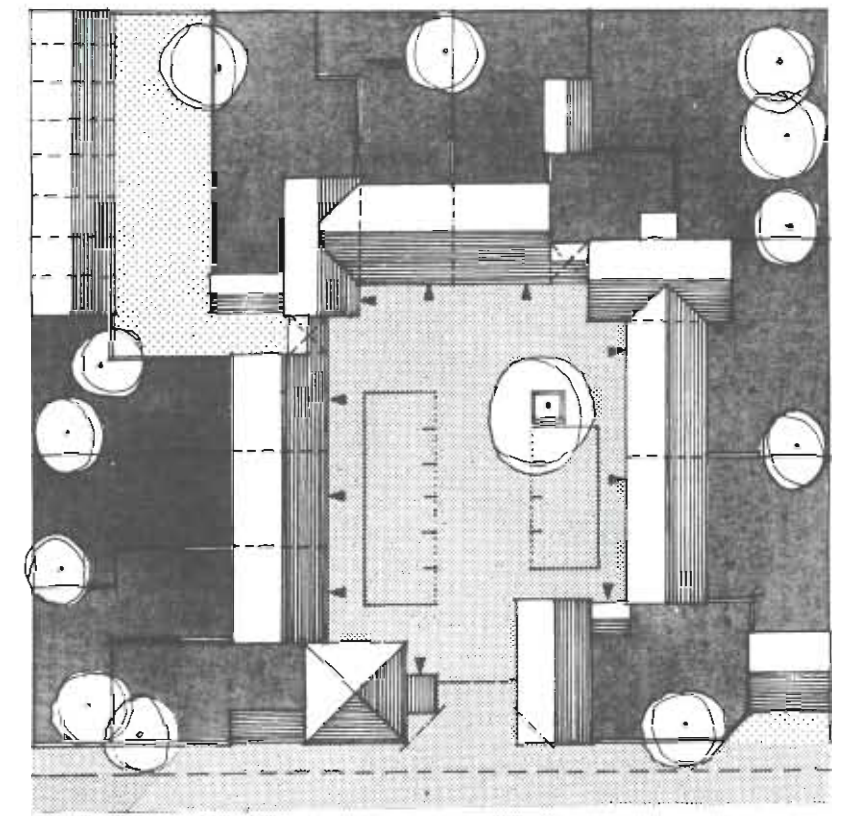

4.151 e Mews court (square)

Casual Parking

As mentioned, to achieve good enclosure, parking should not normally be in front of dwellings. To make attractive places, care should be taken to reduce the impact of parked cars. Suggested methods are:-

Siting between, under or behind buildings; screening by changes in level, walls and planting.

Garaging

Another dominant and disruptive element in modern housing. It should, therefore, be segregated and screened from public spaces, or integrated, so that it forms part of the fabric of the place, using the same 'family of forms' and materials as the dwellings. Care should be taken to ensure doors are not unduly obtrusive. The sketches illustrate the problems and an approach to a solution.

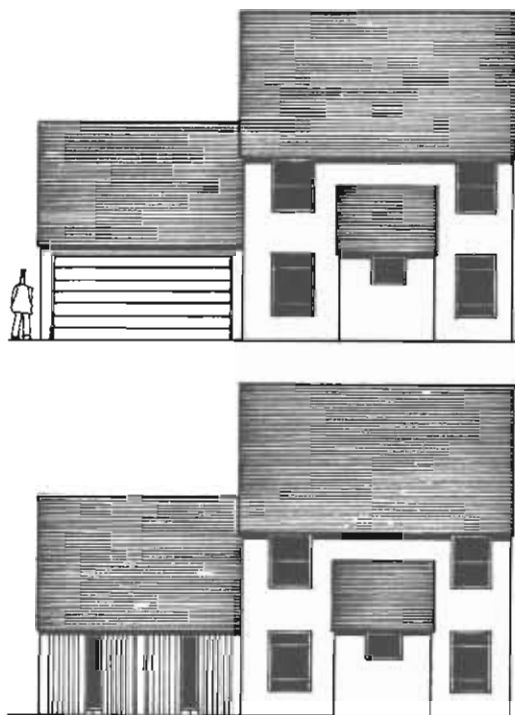

4.151 f Subdivided doors give better scale

4.152

Space between buildings

The Wall Plane

All the foregoing practice notes imply the concept of attractive areas, whenever the public have access and private spaces where visual quality is an option of the resident. The division between the two normally being the dwelling or garage. If this is not the case a permanent above eye-level wall should be provided with solid gates. Changes in level of walling needs careful consideration, as vertical steps give untidy and restless results.

Traditionally, this was avoided by laying to the slope, or leading the eye down gently, with a transitional slope.

Projecting tops to piers also have a visually restless quality and should generally be avoided.

Again traditional solutions are worthy of study.

Walling, if of the same brick as adjacent structures, provides a unified visual extension to the built forms and can add apparent variety to a limited range of house types by responding to particular siting

The Ground Plane

For notes on the surface treatment of roads, pavements, etc., see sections 4.141 and 4.142.

4.2

Low Density Case Study

4.21

Site features

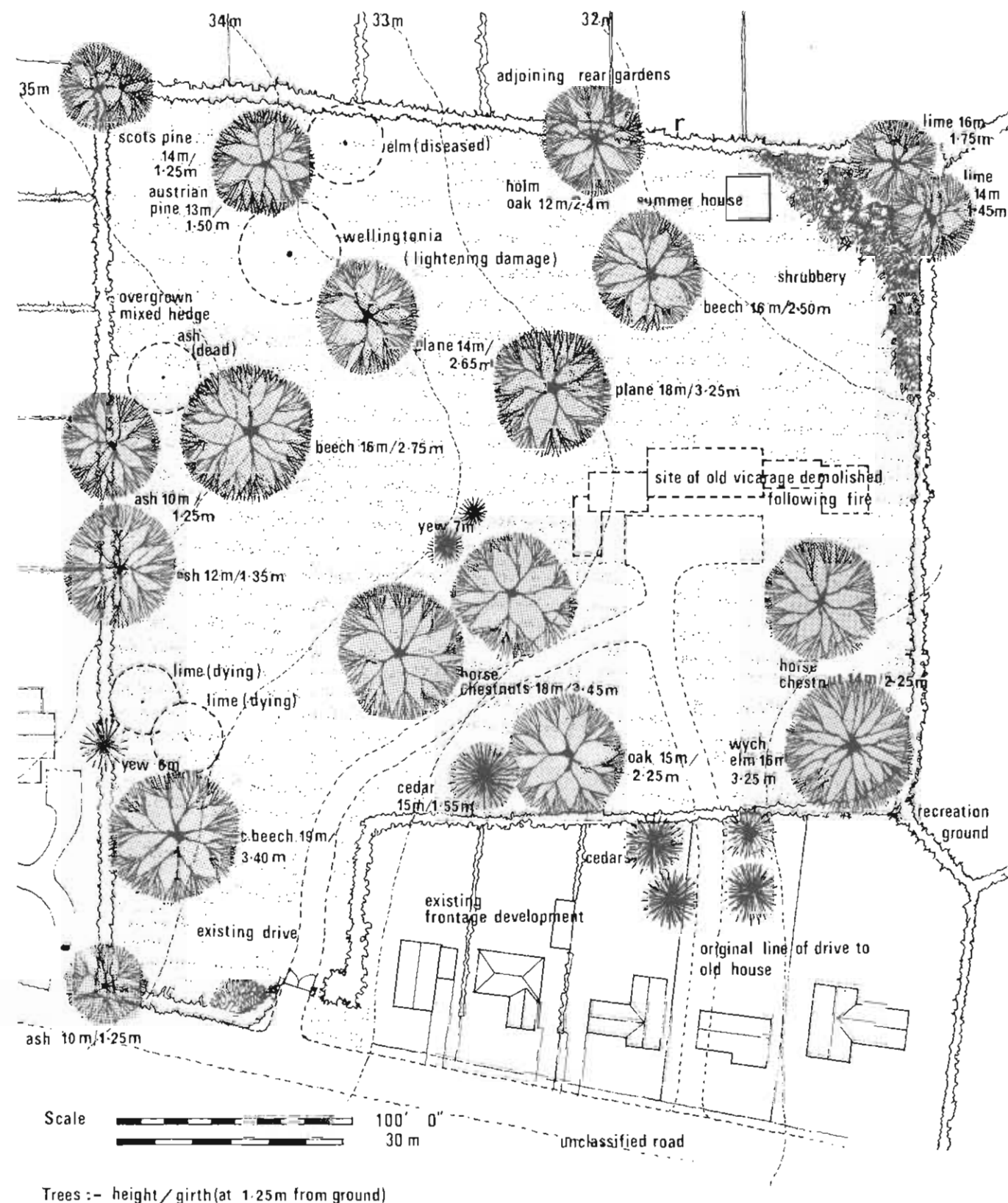

Trees :- height/girth(at 1.25m from ground)

This drawing shows:-

1. Survey of existing trees, indicating height and spread and girth, with those to be removed shown dotted. The remainder are worthy of a Tree Preservation Order.
2. Surrounding boundaries, adjoining development, existing access, and levels.
3. Site of demolished buildings and large 'summer house' suitable for conversion to a garage.

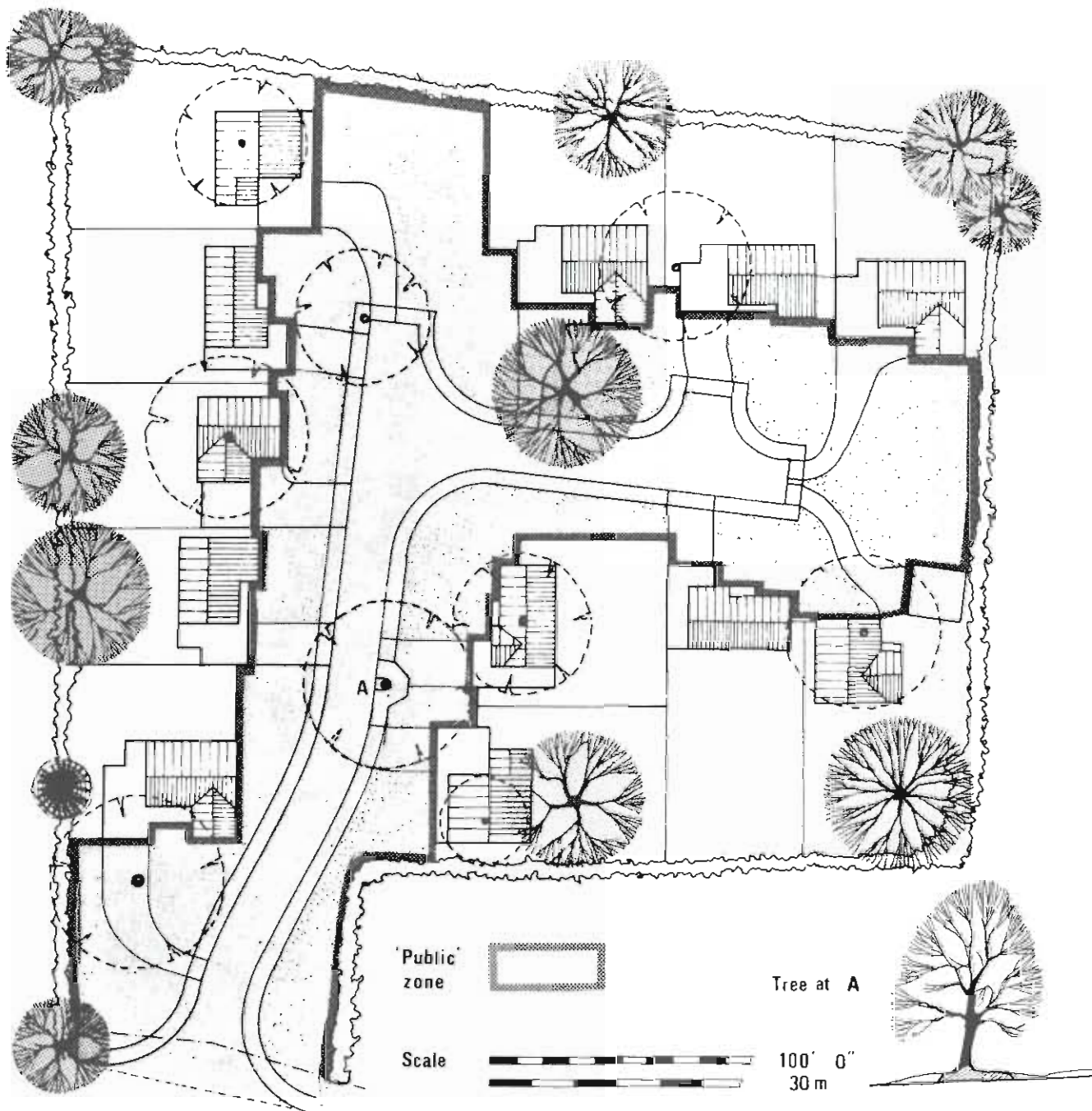

11 dwellings per hectare (4.5 dwellings per acre) fails to meet the following physical and visual criteria.

1. PHYSICAL

- (a) Fails to utilise space efficiently 46% of site used for public zone (unscreened access drives are part of the public zone).
 (b) Insufficient privacy by remoteness or design (See sections 2.13 and 2.21)

2. VISUAL

- (a) Fails to opt for either urban or rural systems of spatial organisation landscape does not dominate—buildings do not contain space.
 (b) Fails to take account of physical characteristics—8 trees felled; tree at 'A' will die; too close to road, roots damaged.
 (c) Roads, driveways and parked cars too dominant.
 (d) There are no walls to permanently screen private gardens from public places.
 (e) House types fail to meet visual criteria set down in section 3.44.

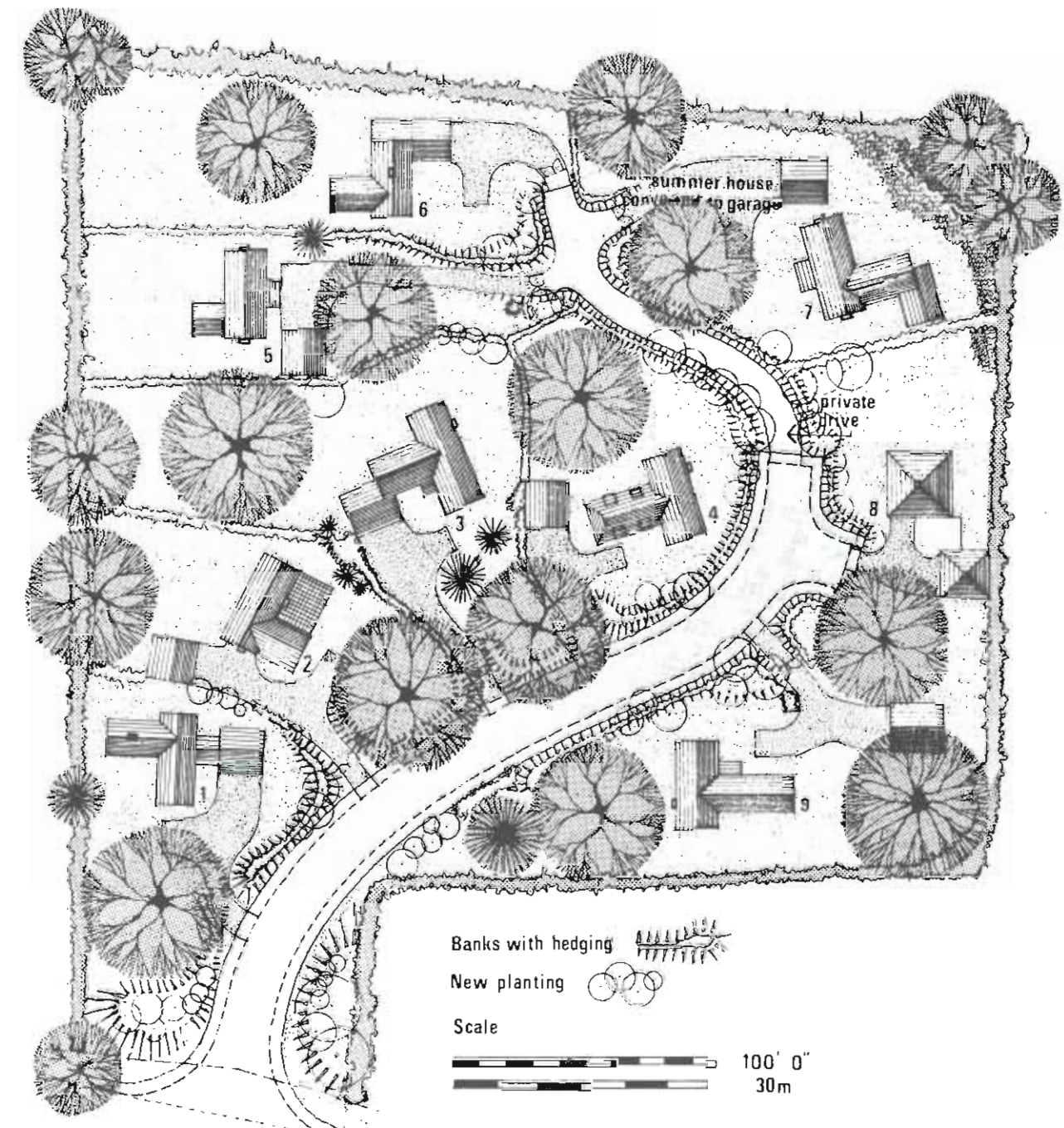

NOTE: It would of course be possible to develop this site at a higher density than shown in 4.23, and still retain the trees. This would, however, involve the use of both urban and rural principles of spatial organisation. If, for example, houses 1, 2, 3 and 4 are linked together by further buildings, urbanism is immediately the dominant principle, the trees will modify the urban space. (see 3.316 the architectural use of trees).

(as illustrated above in Fig. 3.316c)

8.5 dwellings per hectare (3.5 dwellings per acre). Designed to satisfy the physical and visual criteria not met by the unacceptable scheme 4.22.

1. PHYSICAL

- (a) Utilises site efficiently—only 20% used for public zone, (access drives, screened and gated, are part of private zone).
 (b) Privacy requirements met by design—in public zone buildings set back to allow screening by hedges, banks and trees. In private zone landscape or remoteness effectively prevent overlooking.

2. VISUAL

- (a) Uses rural system of spatial organisation, landscape contains and dominates buildings.
 (b) Existing trees are retained; their random grouping suggests informal arcadian solution.
 (c) Winding road with dark surface combined with parking and garaging concealed in landscape reduces visual intrusion of the vehicle.
 (d) New hedges, banks, and tree planting visually contain the public space.
 (e) House types are designed in accordance with the criteria in section 3.44.

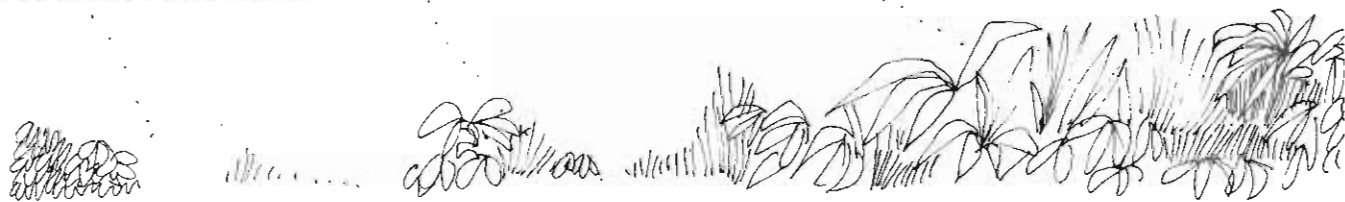

4.23 a Informal Arcadia

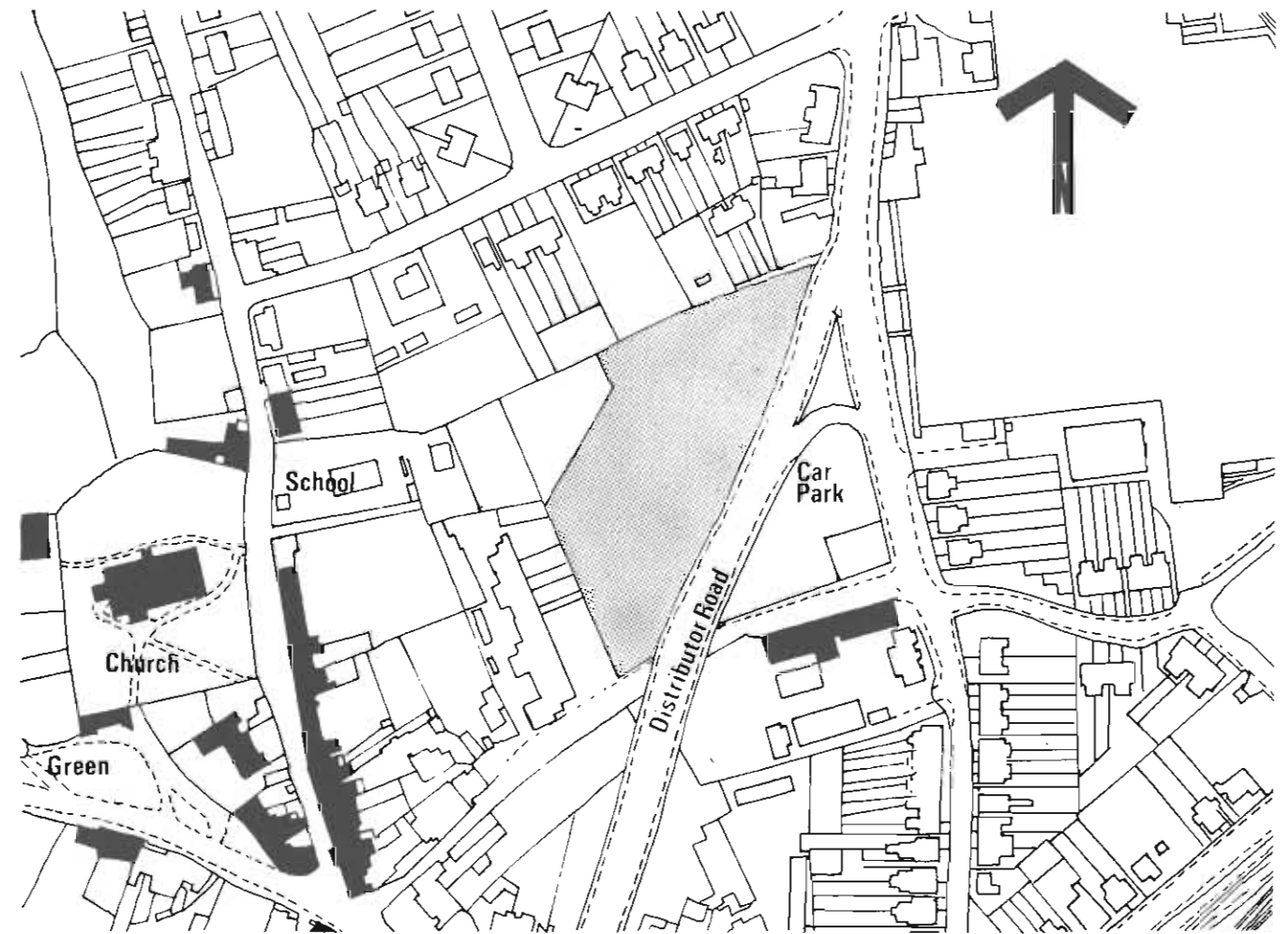

The awkwardly shaped site of this study area was created by the construction of a new relief road to a market town centre. The site of .66 hectare (1.6 acres) is virtually flat, treeless and is embedded in an area of mixed residential and light industrial development of the 19th and 20th Century. The buildings in the vicinity of the site are undistinguished with the exception of two early 19th Century, listed, warehouses to the south. However, the only access to the site, along a lane severed by the construction of the new road, connects directly to a Designated Conservation Area with a considerable number of buildings of architectural or historic interest (shown black on the plan). The new road is a major factor in the development of the site, as it is fairly heavily trafficked and a source of noise. Most of the boundaries to the north and west are on to existing private spaces, making the areas of the site adjacent to them unsuitable as new public spaces. To the west is an existing school and a new footpath link through the site to this would be a worthwhile objective.

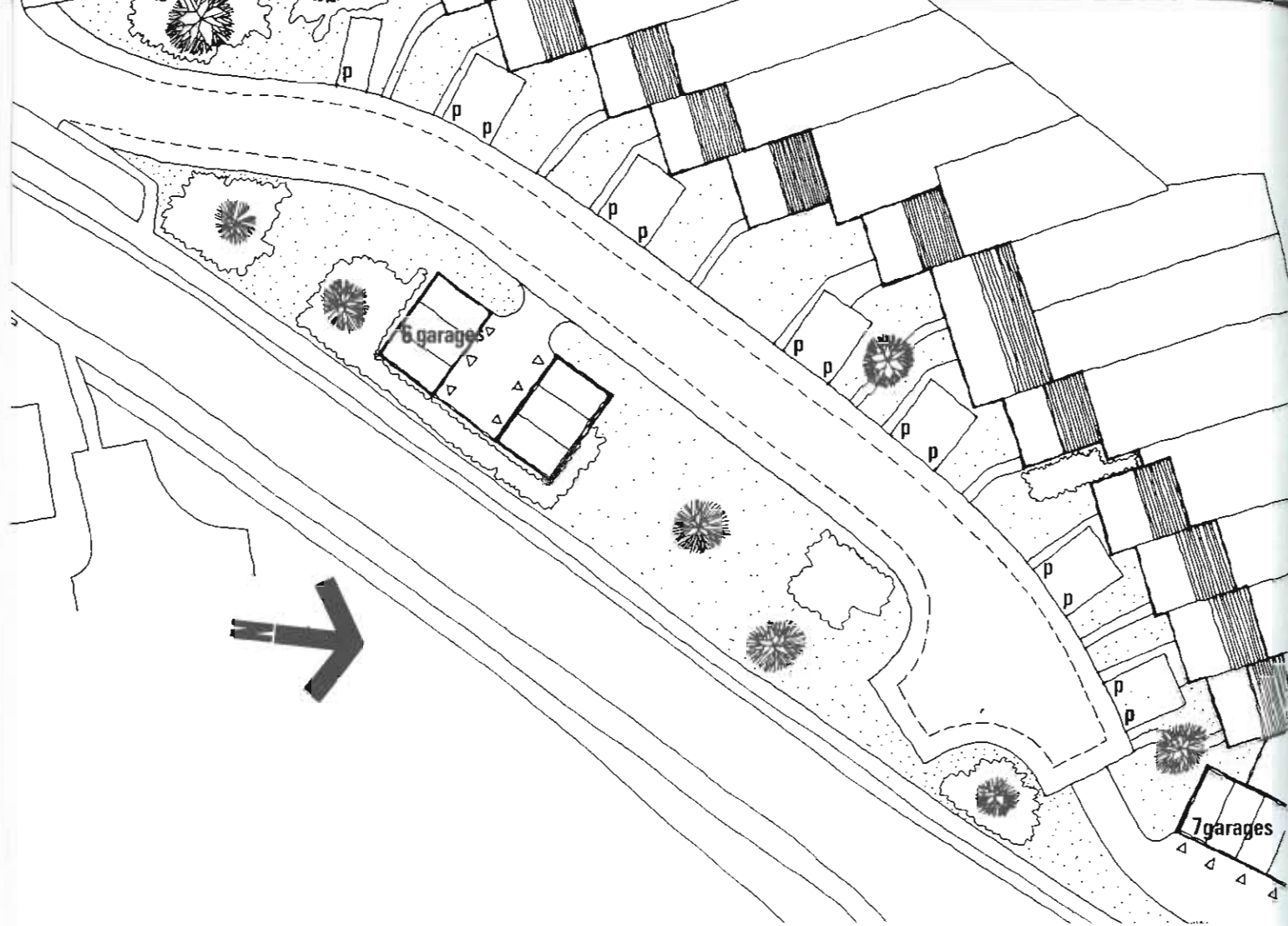

4.32

Unacceptable scheme

Uses neither the rural nor the urban system of spatial organisation. The site is too narrow to accept this suburban type of development on both sides of a road, therefore only one side is developed. To try and avoid this being uneconomic, the maximum number of dwellings (13 terrace units) are crammed along the single frontage. This developable length is so precious that garages have had to be divorced from the houses and sited in blocks on left over land. The dwellings face a public space which has no sense of enclosure and is dominated by parked cars, garages, the estate road and the relief road with its fast moving heavy traffic.

This unattractive, low density scheme of terrace houses is unlikely to be very profitable, therefore the tendency will be to use cheap materials and details to cut costs, thus further reducing the quality of the external environment.



4.33

Suggested alternative layout

KEY

- ▲ house access
- △ garage access
- ▬ new building
- ▬ above eye level wall
- ☼ new planting
- p parking space

Fenestration limitations

- ↔ normal windows to ground & 1st floor
- ↔ normal windows to ground floor only
- ⟨·⟩ normal windows to 1st floor only
- ⟨· high level windows at 1st floor only

The Visual Criteria in Practice

The scheme uses the urban system of spatial organisation, consisting of a short curving street, with an effective height width ratio of 1:2.5, terminated by a small static square.

Leading from the square is a strongly enclosed linear space (based on a Type 5 road) and narrow pedestrian ways leading to the school and town. All these places are secluded from the noise of the relief road, which is treated as a separate linear space, bounded by walls buildings and trees, to give it an attractive edge and isolate the adjoining gardens.

All the houses and garages use the Essex vernacular range of materials and visually articulated additive forms of the same family.

Integration of Physical and Visual Requirements

By making use of the space saving type 5 road; privacy by design and the elimination of all useless space on the public side, it has been possible to develop both sides of the streets, thus more than doubling the useable frontage.

This distance is now sufficient to accommodate 22 linked detached and semi-detached houses, all with garages next to the unit.

The scheme is not only attractive but makes efficient use of an awkwardly shaped site.

Steep pitched roofs to garages aid visual enclosure of the street. Where buildings do not separate the public and private zones, the division is provided by above eye-level walls.

The visual dominance of parked cars is reduced by siting between buildings.

Adequate interest and identity is given to the street scene by using a limited range of house types but varying the grouping and roof sections and by the use of garages, porches and walls as linking elements to add further variety to the architectural compositions

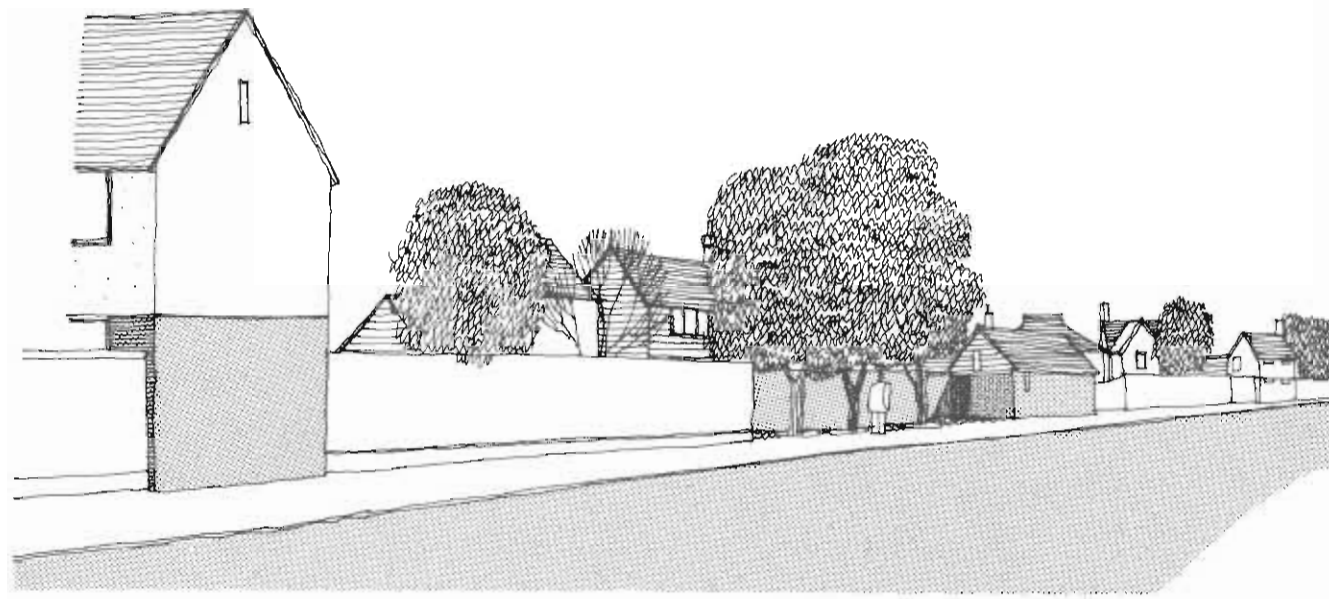

4.33 a

The new urban edge to the relief road



4.33 b

The square showing entrance to mews court

This site of approximately one acre, is made up of gardens to the rear of properties fronting a medieval market place and adjoining street (Listed Buildings are shown in black).

As the plan shows, it is an important area of 'backland' very close to the centre of this attractive market town; new development must obviously reflect the 'grain' and structure of this existing settlement. The Listed Building connected to this site, on the market place frontage, is a good Georgian Town House and has been converted to prestige offices. The site itself falls steeply from east to west affording good views over the roofs of existing properties to the west and north/west. There is an abrupt change of level at one point where a retaining wall was constructed to form a tennis court. One very large Horse Chestnut tree stands within the site and this is marked with a circle on the plan. All the boundaries are formed by high red brick walls of 18th Century construction and there is an attractive, thatched summer house on the corner of the boundary walls close to the Chestnut.

Vehicular access can only be gained over the frontage of the narrow street to the east, but additional pedestrian ways can connect to the market place beside the Georgian House and to the north/west via the existing lane.

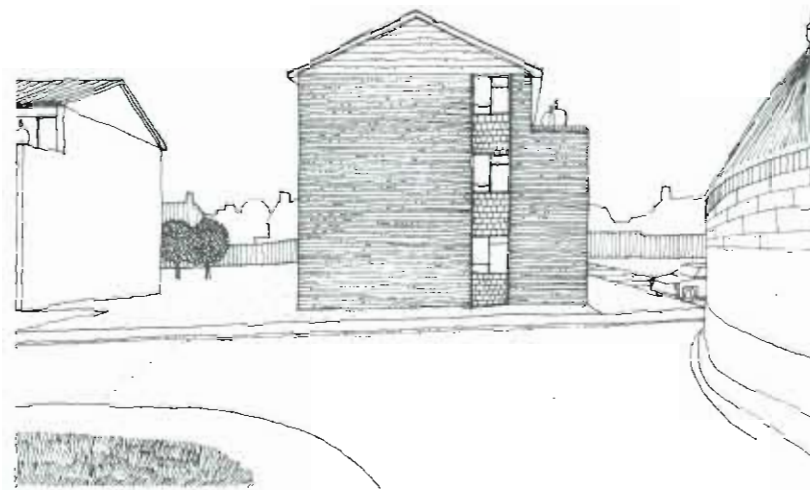

Sketch from viewpoint A.

(1)

An unsatisfactory suburban concept uses neither the Rural nor Urban system of spatial organisation. Buildings are not set in a dominant landscape (even the existing tree must be felled) neither do they enclose space.

(2)

There is no clear concept of attractive public and private zones, with the result that all units face onto, or are approached by an amorphous space, dominated by asphalt, parked cars and garage doors. The remaining open space is unattractive in shape and being in no way private, is unlikely to be used by residents as a sitting out area.

(3)

The buildings are not well designed. The deep plan and balcony access arrangement producing blocks with a crude and dominant gable elevation consisting of two badly articulated forms of different families. Tile hanging which is not an Essex tradition is used in an arbitrary manner, visually weakening an apparently loadbearing wall. The unbalanced subdivisions in the window openings add a further restless element to the visually ambiguous design. The use of flat roofed garages is particularly unfortunate with flats development, as many living rooms will have views out on to unsightly felt, or asbestos cement roofs, further emphasising the drab nature of the garages and parking areas.

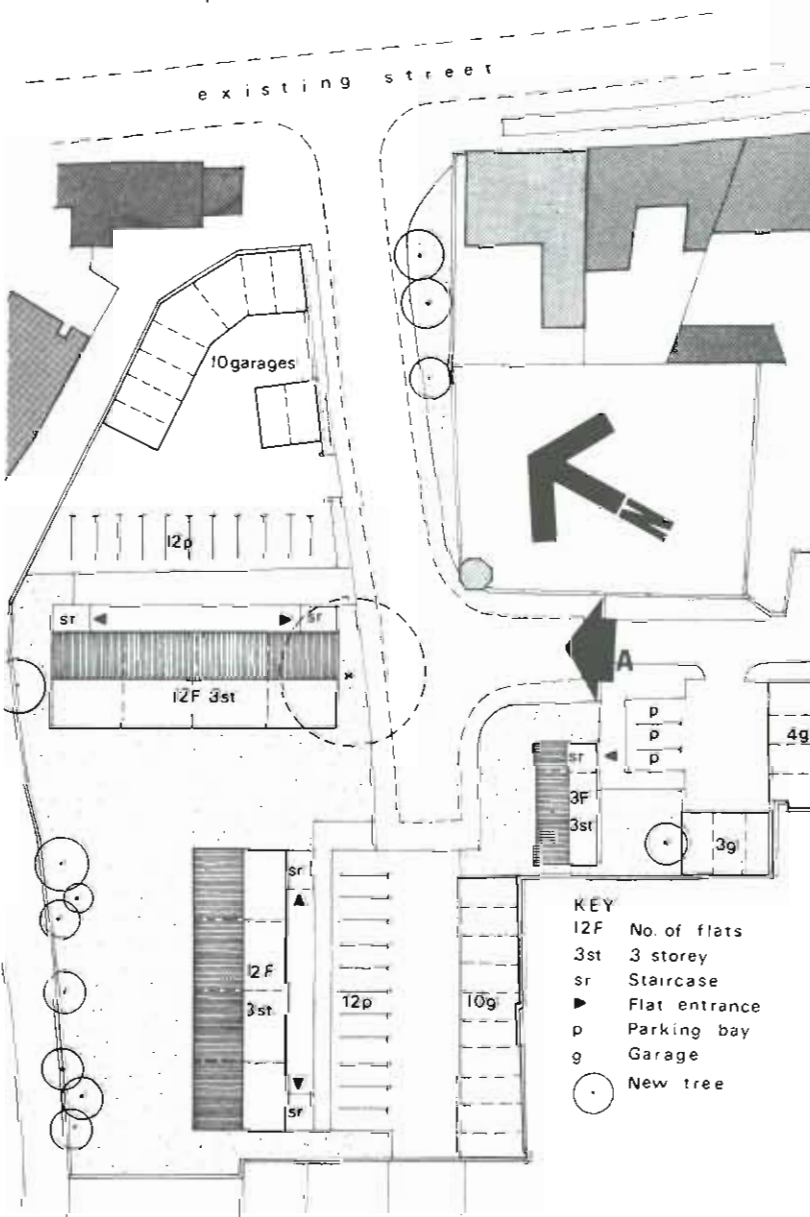

Sketch from viewpoint A.

The Visual Criteria in practice

The study area uses the urban system of spatial organisation - the flats are planned to make a satisfactorily enclosed relatively static space, the fine existing tree being retained as a central feature.

Due to the restricted site it was not possible to make a formal square and retain the tree; therefore the informal character of the space has been emphasised by the use of informal architectural compositions of 2, 3 & 4 storey buildings. All the flats and garages use visually articulated 'additive' forms of the same family.

Integration of Physical and Visual Requirements

To make the development attractive to residents and visitors, open space has been organised to form public and private zones. All units face on to a public space, but to enable residents to relax out of doors, the remaining open space is designed to allow each occupier to have access to either a communal private garden, or a private balcony or sitting out area.

100% casual parking is sited near to each flat block entrance to avoid parking on the highway. This provision is designed to avoid parked cars dominating the urban scene, by placing them under buildings, or in courts reached by archways through their facades.

Garages are incorporated away from the main public spaces to avoid visual dominance of the motorcar in the urban scene.

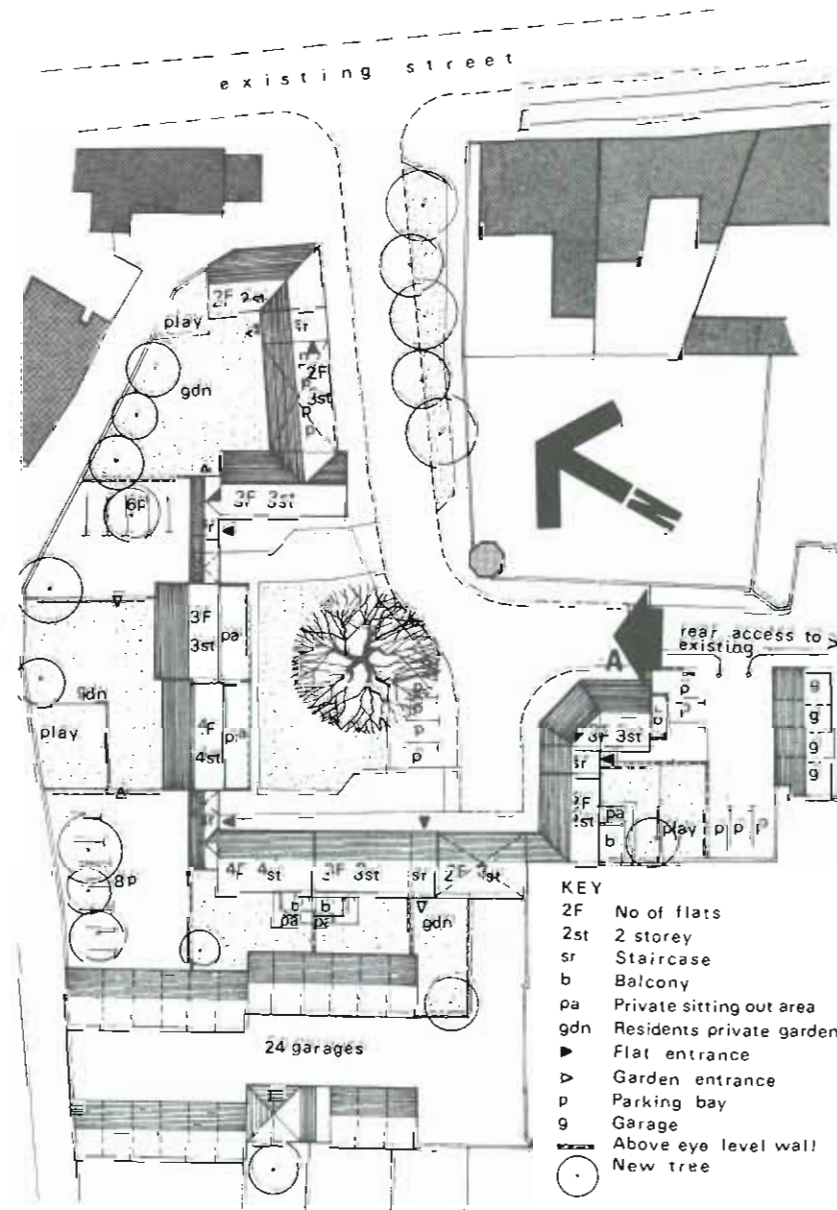

A typical scheme, acceptable under former control, which would fail to meet the new policy.

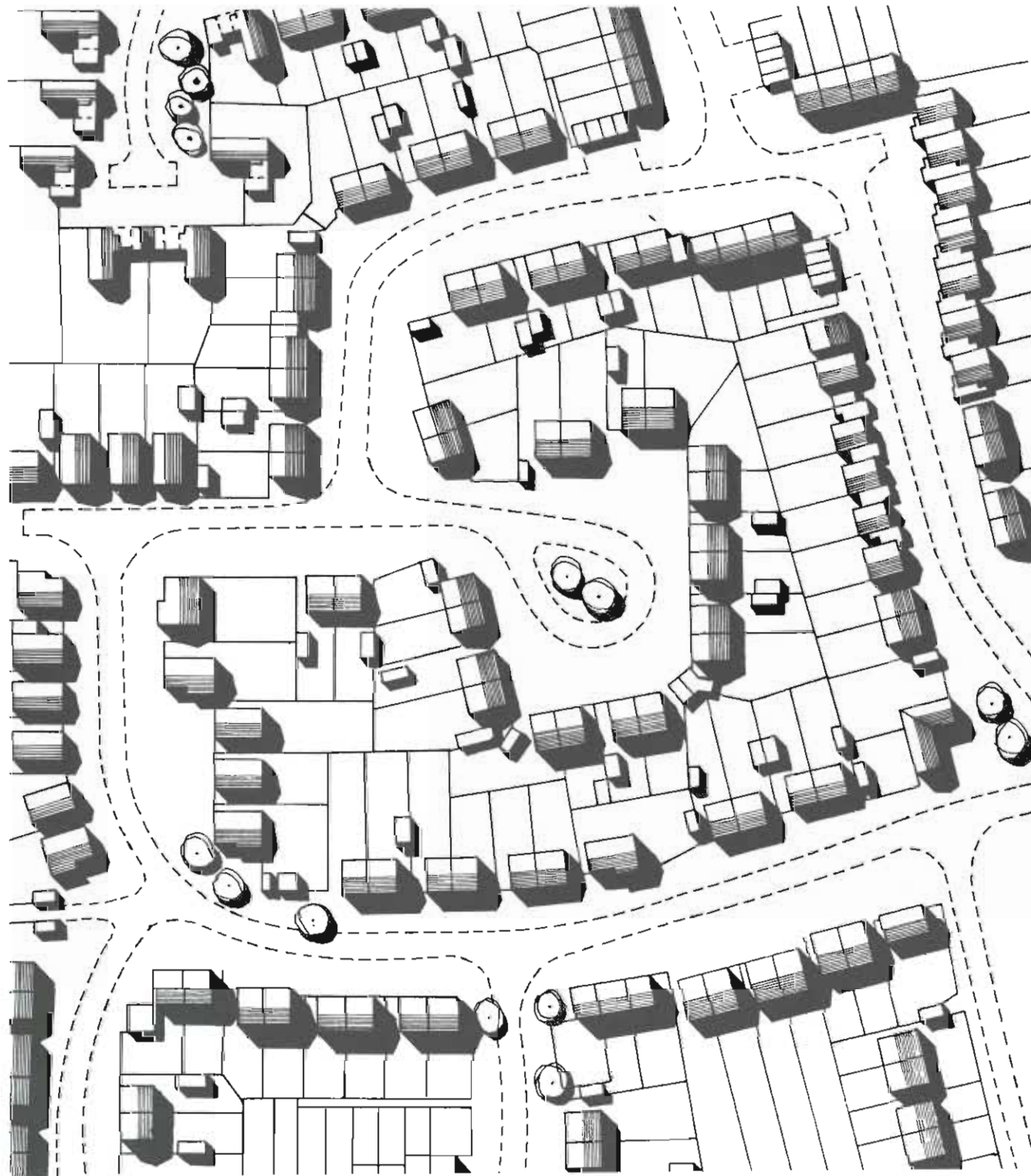

Physical Faults

- Density. At an average density of only 25 units per hectare (10.5 units per acre), the scheme fails to reach the Written Statement requirement of 13 to 15 dwellings per acre for an urban scheme.
- Inadequate privacy for dwellings and gardens.
- Some gardens too small, with no compensating landscaped open space.
- No hierarchy of routes for vehicles or pedestrians.
- Highway layout fails to meet the new standards.





Visual Faults

- A suburban scheme, which uses neither the rural nor the urban system of spatial organisation. The public side is too cramped to accept adequate landscape to form an arcadian scheme and is not organised to make satisfactorily enclosed urban spaces: all the spaces having an inadequate mean effective height for their width and the monotonous architectural compositions further emphasise the formless nature of the places.
- Impermanent and unsightly fences are frequently used to separate the public and private zones.
- Parked cars will be very dominant, as most hardstandings are in front of the dwellings.
- The buildings are not well designed. The Plan indicates the inherent problems of subtractive form, mixed pitched and flat forms, dominant gable ends and houses which are sited to require all the windows in the gable ends.

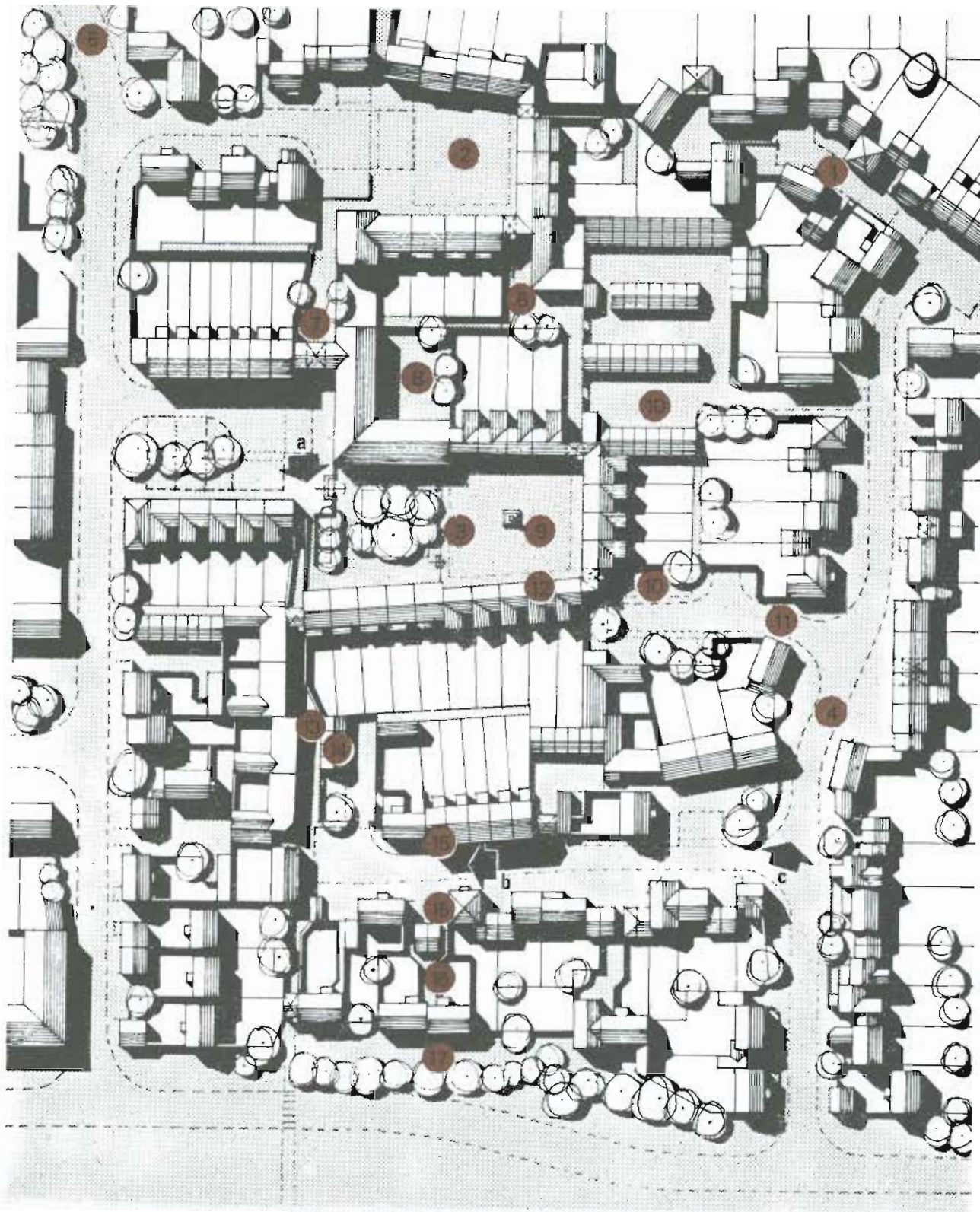
PHOTOGRAPH - Typical Suburban Scheme





- Key:
-  Essential tree planting to enclose space
 -  Essential wall above eye level to enclose public space
 -  Fencing to back gardens
 -  Viewpoint of sketch - Figs 4.52 a,b&c
 -  Key to Criteria Notes

The Visual Criteria in practice

This study area uses the urban system of spatial organisation, consisting of a series of satisfactory enclosed contrasting spaces. For example:

- (1) Assertive tight linear street (height width ratio 1.1).
- (2) Static square (height width 1.4) with a passive character.
- (3) Over long static space modified by trees to form a satisfactory static and circuit linear space.
- (4) Long linear space visually divided into a series of sub spaces, to reduce the apparent length. Monotony further avoided by grouping buildings to form interesting architectural compositions with variety of roofline gained where possible by the use of 2 and 3 storey units of varying span and roof pitch. All houses and garages use visually articulated additive forms of the same family.

Integration of Physical and Visual Requirements

- (5) Start of adjacent landscape dominated area. Low density is easy to reconcile with highway requirement of access in forward gear only, onto type 2 road.
- (6) Care taken to ensure that all public zones are attractive spaces screened from the 'private zone' by buildings or above eye-level walls.
- (7) Pedestrian spine route runs along the 'watershed' between cul-de-sac networks to avoid crossing roads and is designed as an attractive series of contrasting public spaces enclosed by buildings and above eye-level walls.
- (8) Attractive communal private garden to flats.
- (9) Pedestrian only squares sited on 'watershed' between culs-de-sac, reduce road length per unit, thus saving money and freeing land for other uses.
- (10) Visitor parking separated from potentially unattractive large garage court.
- (11) Use of 'courtesy section' in footway enables visual gap in frontage to be kept to a minimum.
- (12) Terrace units organised around well proportioned contrasting spaces to avoid monotony inherent in this type of dwelling.
- (13) Single storey units which have inadequate height to enclose wide spaces, sited along narrow pedestrian route.
- (14) Pitched roofs to garages give extra enclosure and interest to this side of pedestrian way.
- (15) Visual dominance of parked cars reduced by siting under or between buildings.
- (16) House with public and private zones on the same side uses only 5m road frontage but this type of layout is only acceptable if opposing dwellings have high level windows at first floor and above eye level boundary walls to avoid overlooking and loss of privacy.
- (17) Care taken to ensure that an interesting and tidy public side is presented to the edge of the 'urban' area, where it adjoins open landscape, or a landscaped area or road.

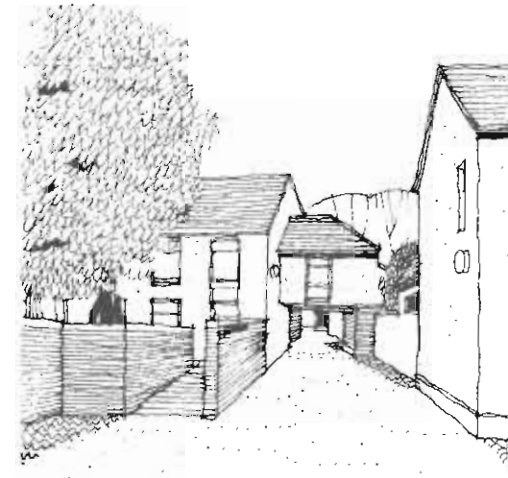

4.52 a











4.52 b







4.52 c

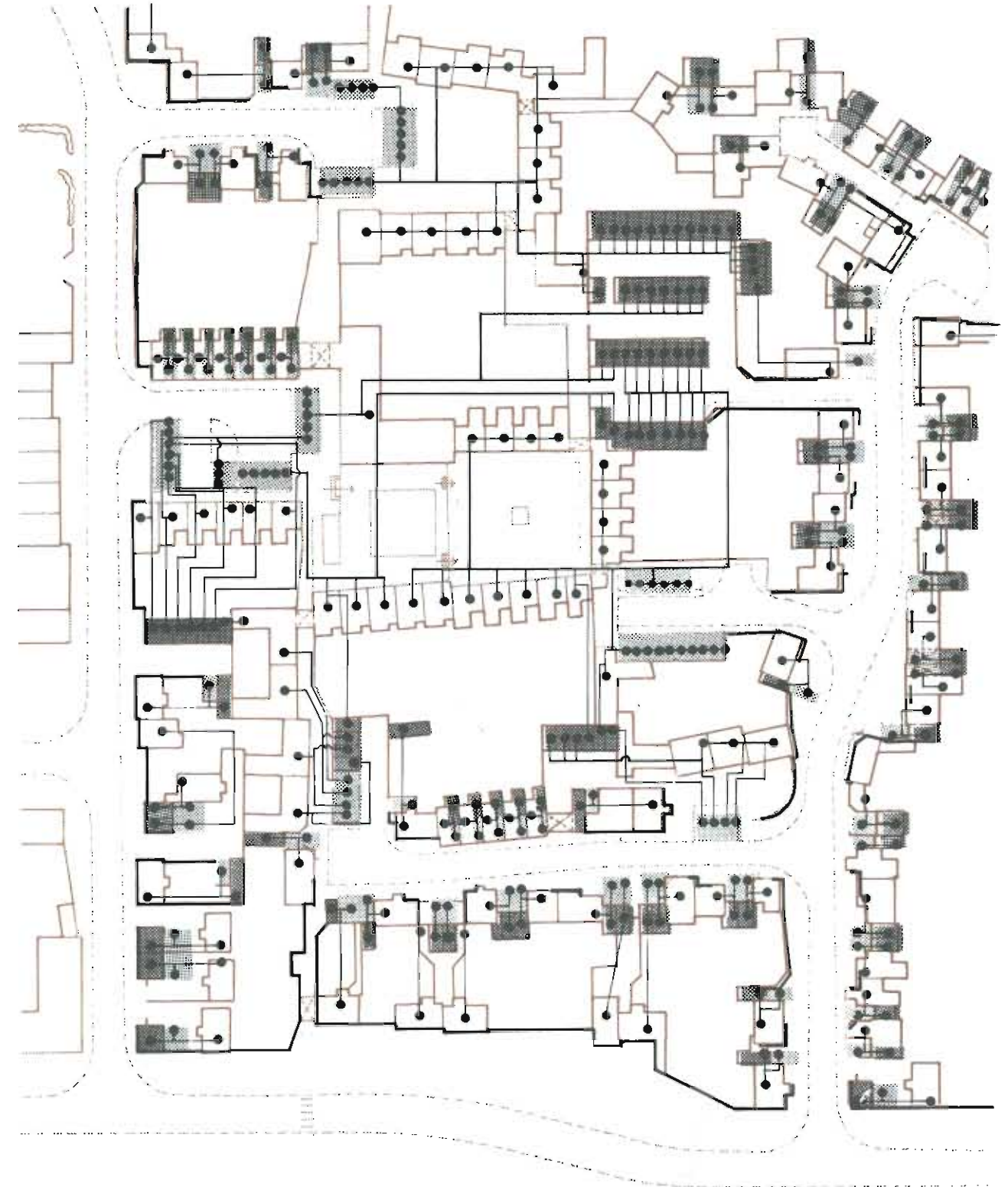

-  type 1
-  type 2
-  type 3
-  type 4a
-  type 4b
-  type 5
-  type 6 (serving a maximum of three units)
-  pedestrian spine route

*These standards are superseded. See separate document, Highway Standards 1980.



-  Garage
-  Parking Space
-  Dwelling
-  Walls without doors or gates to discourage parking on the highway

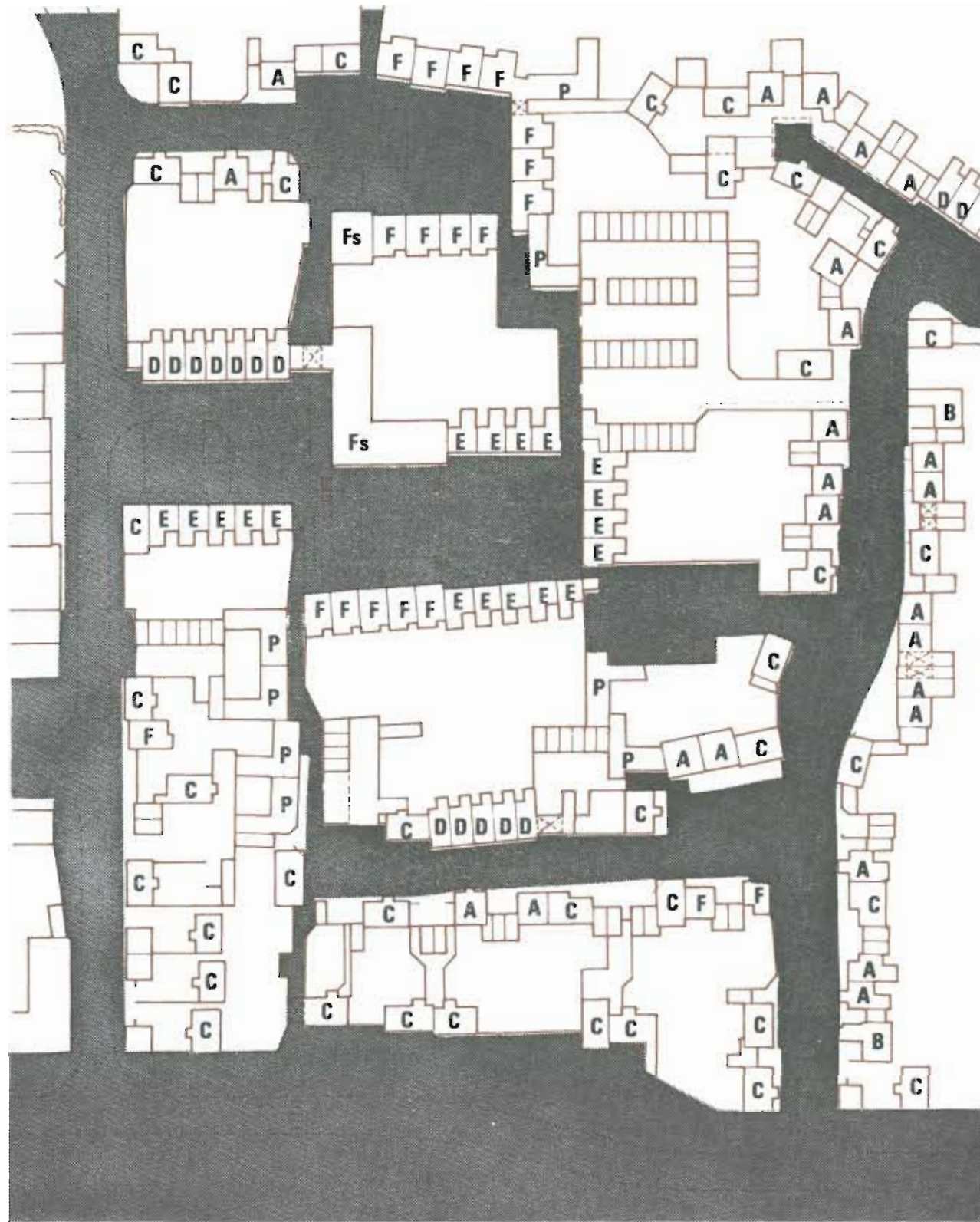

- adoptable area suitable for maintenance by the local authority
- A letter indicates plan type (section 4.53) on which the dwelling is based. note: flats (Fs) and single storey patio units (P) are not illustrated in detail

Criteria Notes type A

- (i) High level windows on first floor rear elevation makes privacy by design possible on private side, for dwellings opposite and adjacent.
- (ii) Visitor parking is largely concealed between units.
- (iii) 'Through garage' enables second car to be incorporated.
- (iv) The position of the staircase is convenient for extension into roof space.

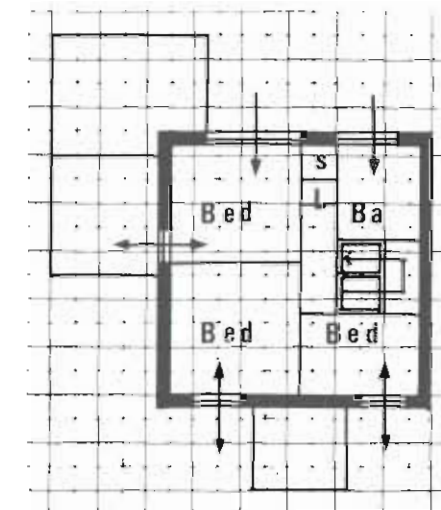
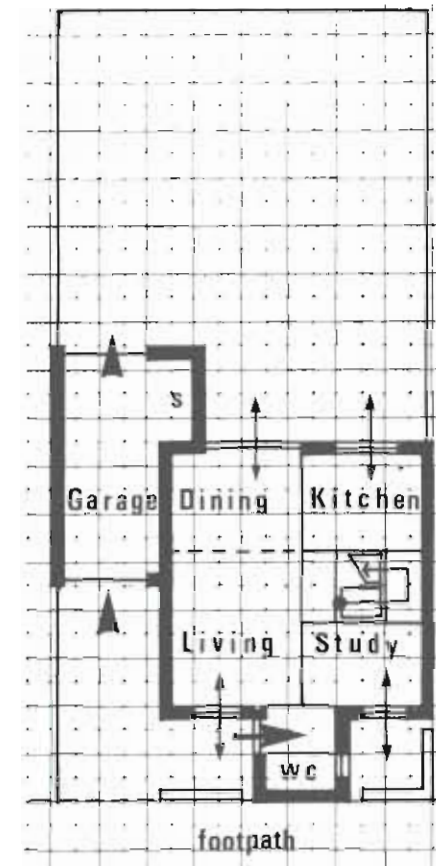

Criteria Notes type B

- (i) High level windows to first floor rear elevation makes privacy by design possible as Type A.
- (ii) Parking concealed between units.
- (iii) 'Through garage'.
- (iv) Slim plan of main block useful for masking over dominant gable elevations of possible adjacent deep plan units.

Key to basic plans

- window with low sill - light in, view out
- window with sill above eye level
- main entrance
- garage door

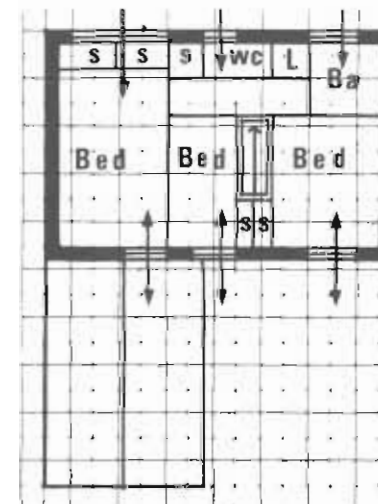
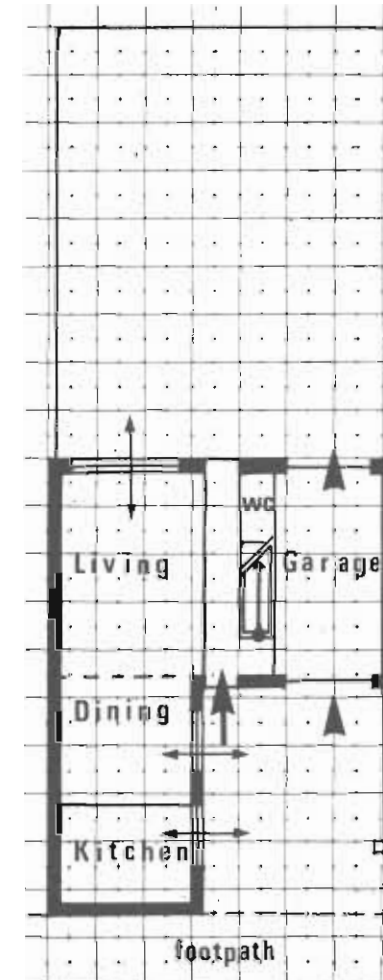

Dimensions based on N.B.A. Generic Plans

Criteria Notes type C

- (i) High level windows to first floor rear elevation make privacy by design possible as Type A.
- (ii) Parking and garage doors concealed from public space.
- (iii) Detached unit with double garage on a frontage of only 10.750m (36 ft.).
- (iv) Slim plan advantage as Type B.

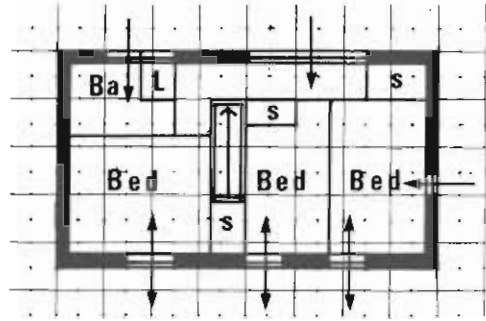
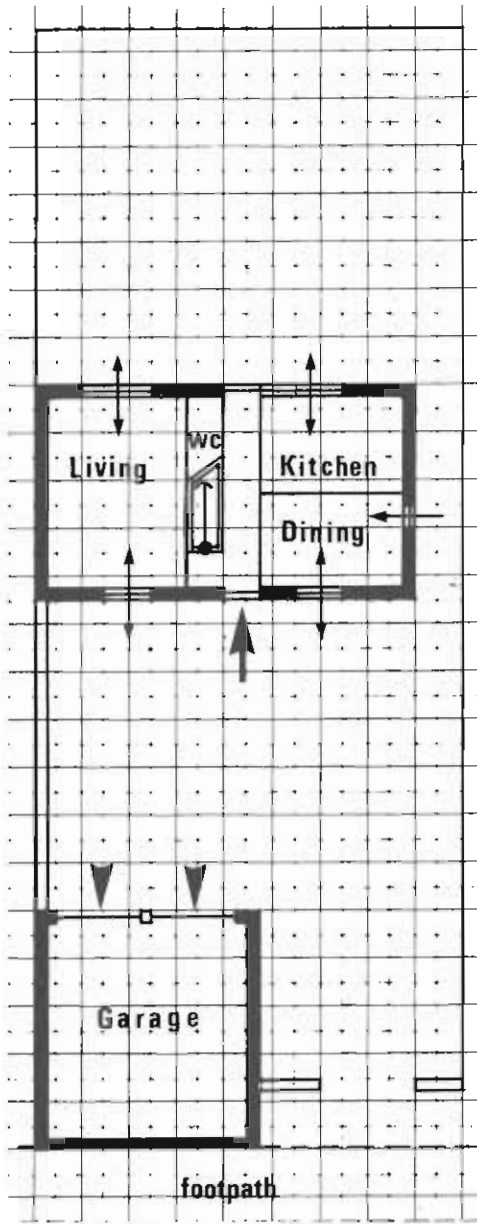

Key to basic plans

- ↔ window with low sill - light in view out
- ← window with sill above eye level
- main entrance
- ↖ garage door

Criteria Notes Type D

- (i) Three storey unit set on back of footpath gives good spatial enclosure.
- (ii) Garage and parking incorporated and concealed.
- (iii) Through garage.
- (iv) Economical on ground cover and road length per unit.

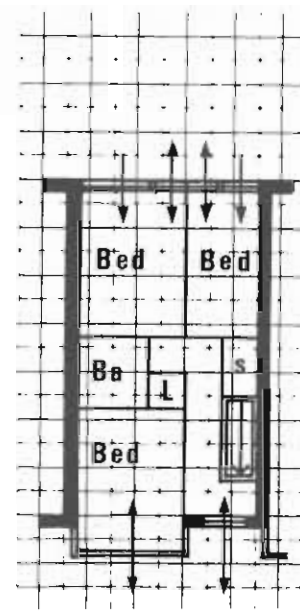
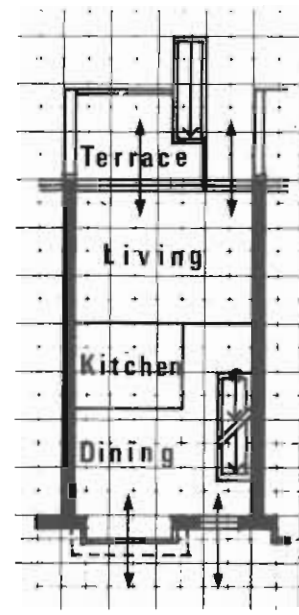
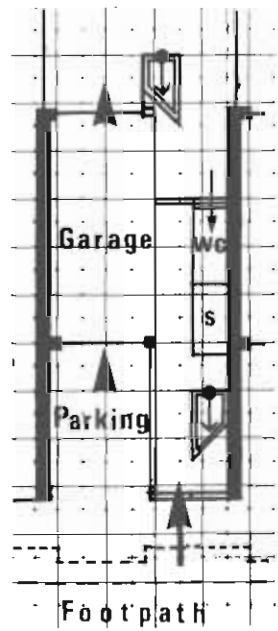

First Floor

Second Floor

Criteria Notes Type E

- (i) Narrow fronted terrace unit useful for enclosing formal spaces.
- (ii) Privacy by design possible on private side.
- (iii) Plan form makes good gable end proportions possible at end of terrace.
- (iv) Stairs positioned to make use of roof space possible.

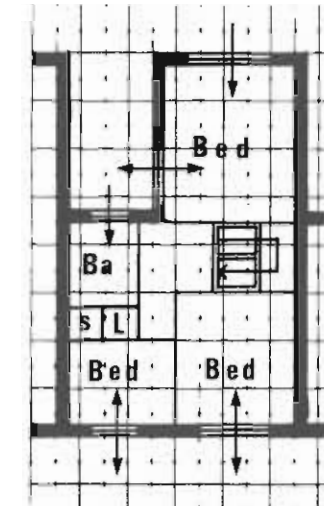
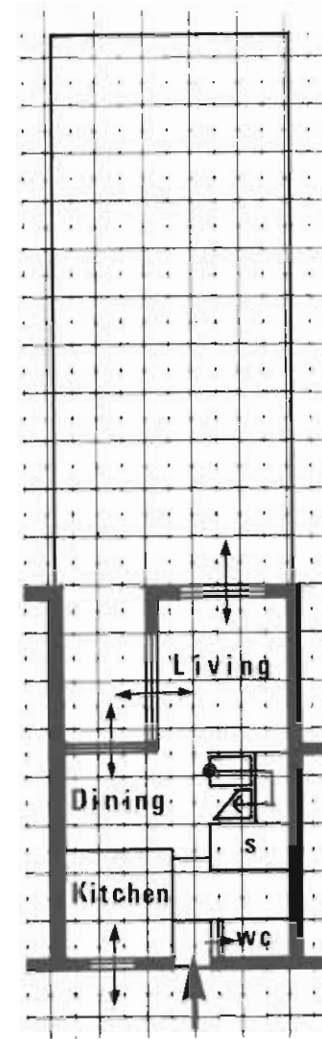

Criteria Notes Type F

- (i), (ii) and (iii) as Type E but living room and kitchen prospect reversed.

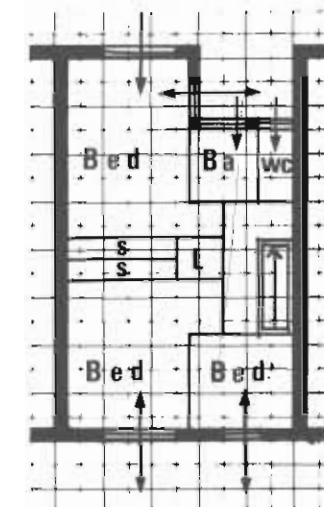
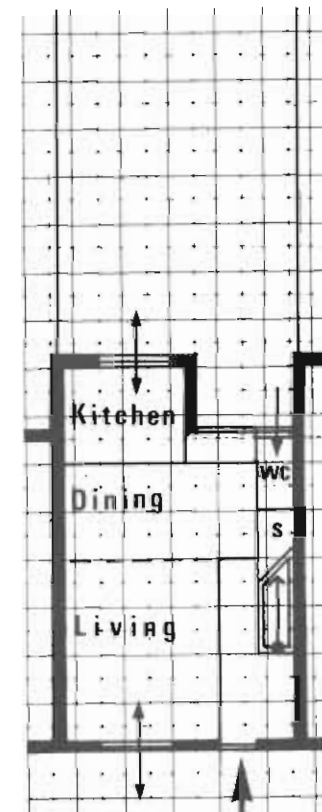

Dimensions based on N.B.A. Generic Plans

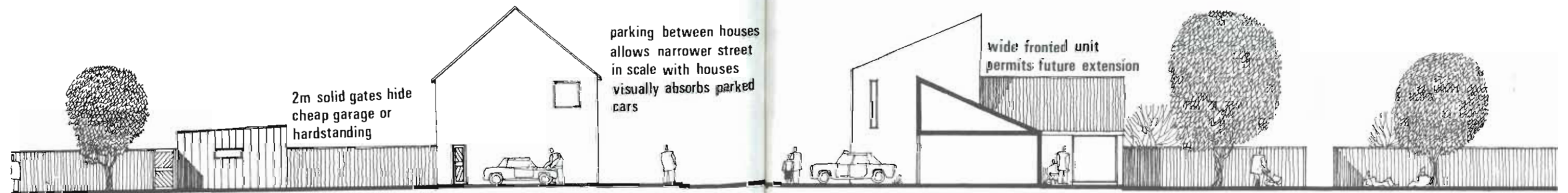
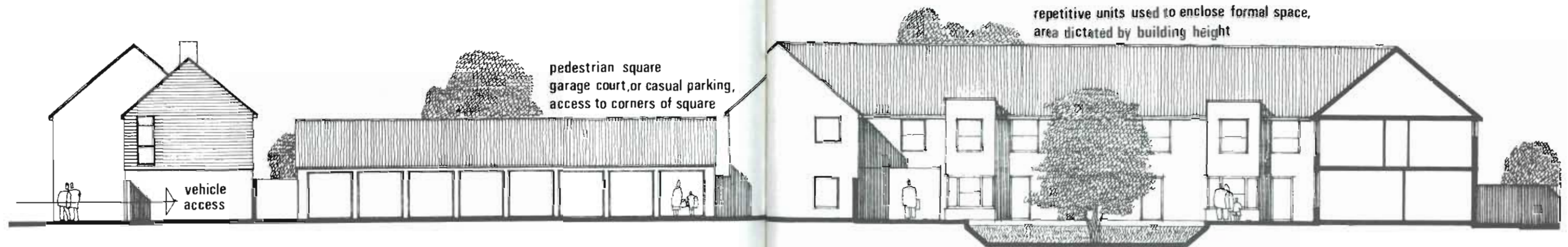
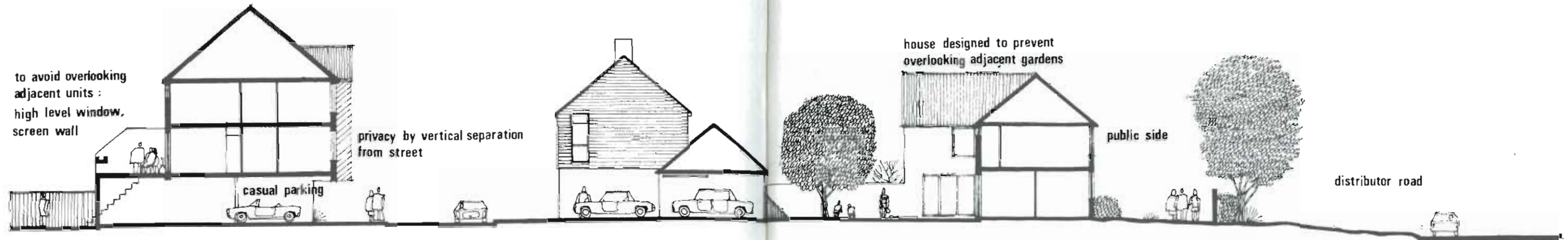

Sections showing further details of design principles used in suggested layout

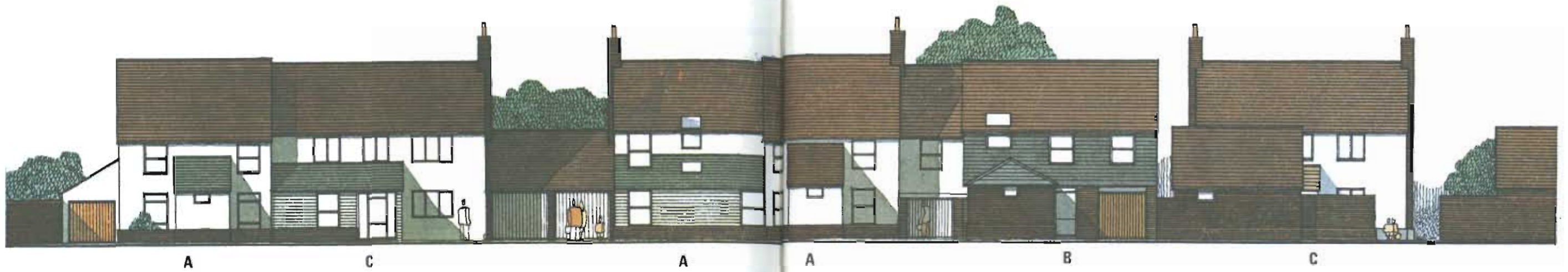

Street Elevations showing some of the varied architectural compositions possible using plans from section 4.63

Colour Plate over-page illustrates the variety of street architecture that is possible using only one house plan, with minor variations (type C)





5.0

CHECK LIST

Does the design satisfy the following criteria?

(2.0)

Physical Criteria

Public zone

- 2.31 General services
- 2.321 Pedestrian access
- 2.322 Vehicular access
- 2.323 Car parking
- 2.324 Servicing
- 2.33 Facilities
- 2.4 Adoption standards

The dwelling

- 2.11 Internal space standards
- 2.12 Extendability
- 2.13 Internal privacy
- 2.14 Sound insulation
- 2.15 Daylight and sunlight

The house curtilage

- 2.21 Private zone
- 2.22 Minimum garden area

(3.0)

Visual Criteria

Public zone

- 3.2 Landscape dominated design principles.
- or
- 3.3 Urban design principles
- 3.42 Local materials

House envelope

- 3.43 House design
- 3.44 Building design principles

Private zone

Private taste.
No criteria unless visible from a public space in which case public zone criteria will apply.

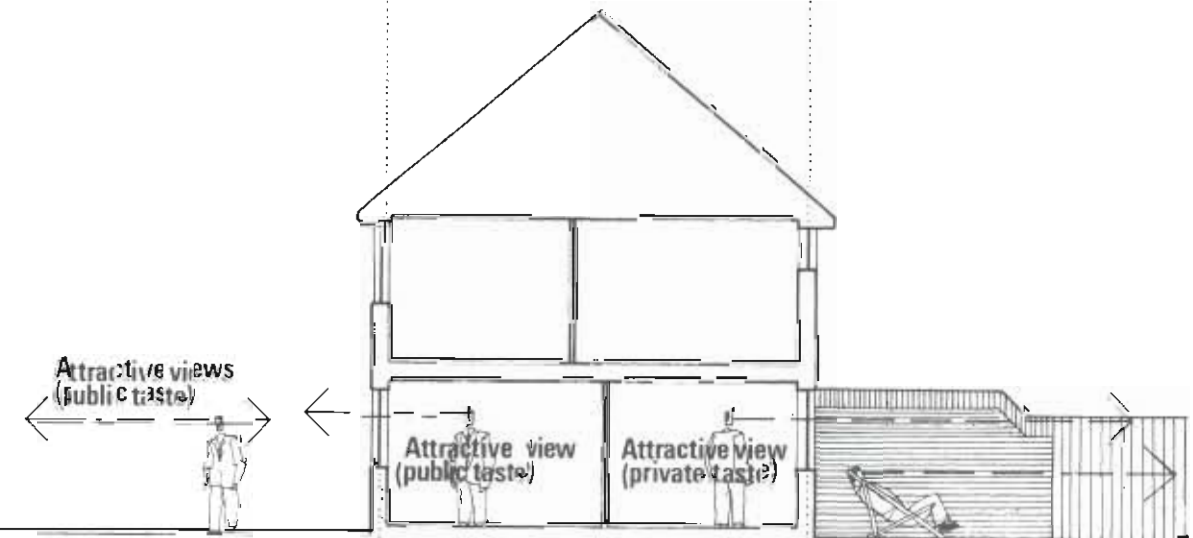

COLOUR PLATE left,
Housing, 'the private zone'.

APPENDIX A

MEASUREMENT OF EFFECTIVE HEIGHT

As has been previously stated, outdoor spaces are defined by the ground plane and the buildings, walls and trees surrounding them. Each space should be regarded as an open topped 'box'; the relationship of height to width of this box has already been discussed (static spaces 1:4 max, linear spaces 1:2.5 max).

In order to determine the maximum desirable width of a space, the 'effective height' of enclosing planes must be discovered.

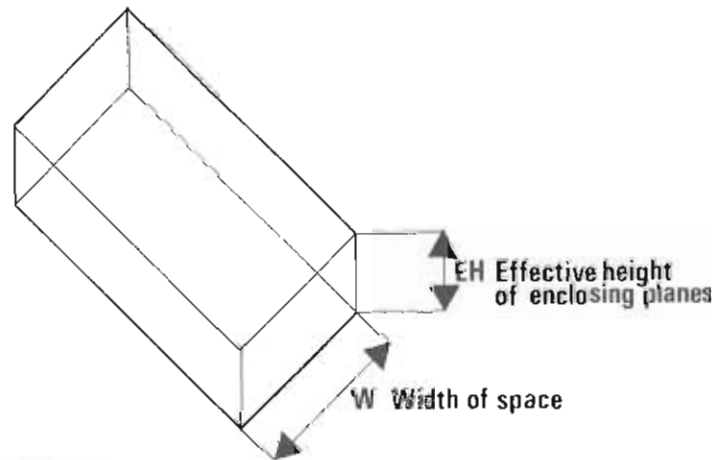

Where continuous flat roof buildings define a space, the 'true height' of the building frontage will be the 'effective height' of the enclosing plane. The sloping roof plane of a pitched roof house will help to define space, but its effectiveness will be dependent on the pitch of the roof, its true height and the position of the observer.

The stated relationships of width to height of space have been arrived at by making the following assumptions. The observer is assumed to be standing 1m (3 ft. 3in.) away from one side of a space, with an eye-level of 1.675m. (5 ft. 6 in.). The 'effective height' of the building will include the true height of the building to eaves level, plus the foreshortened roof area, as seen from this viewpoint.

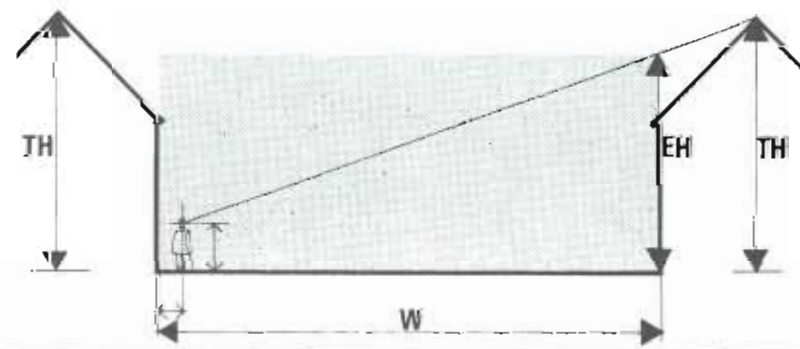

It will be seen that the deeper the plan depth of the unit, the lower the 'effective height' of the building (assuming a constant ridge height).

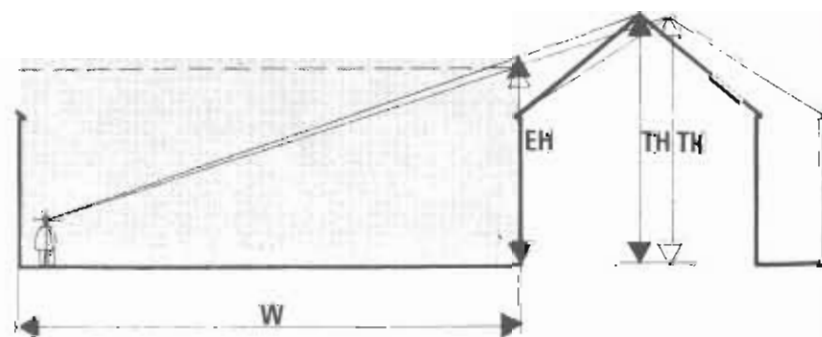

Where the space is continuously developed on its frontages (terrace housing), the effective height of an individual unit will be the 'effective height' of the enclosing plane. However, if the sides of the space are composed of a variety of building heights and/or roof pitches, a 'mean effective height' for the complete group must be determined before arriving at an 'average width' for the enclosed space.

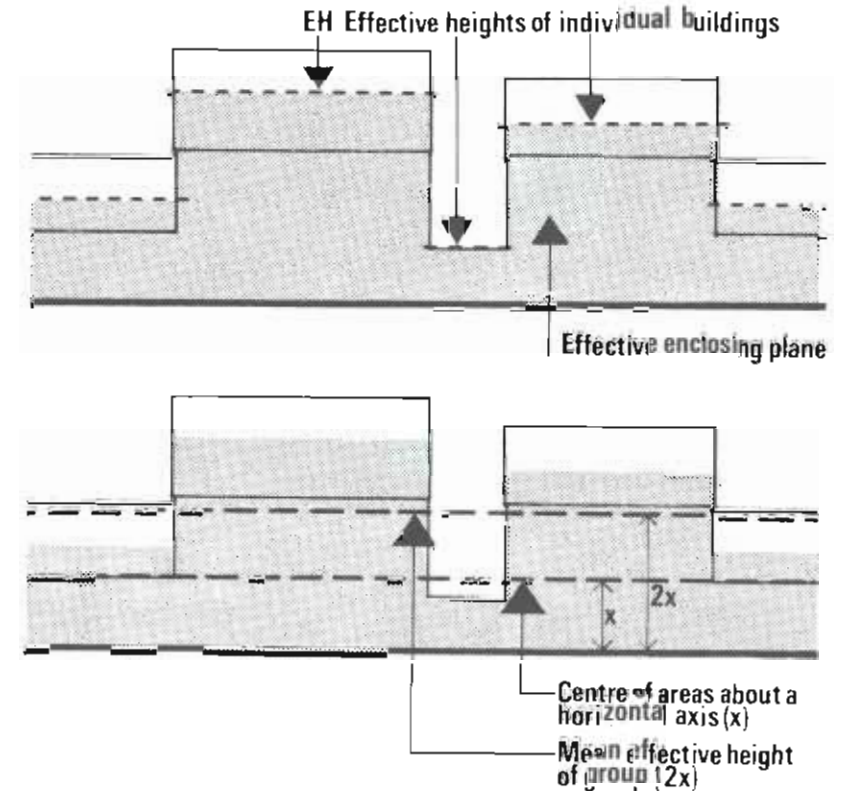

Calculating the mean effective height of one side of a space.

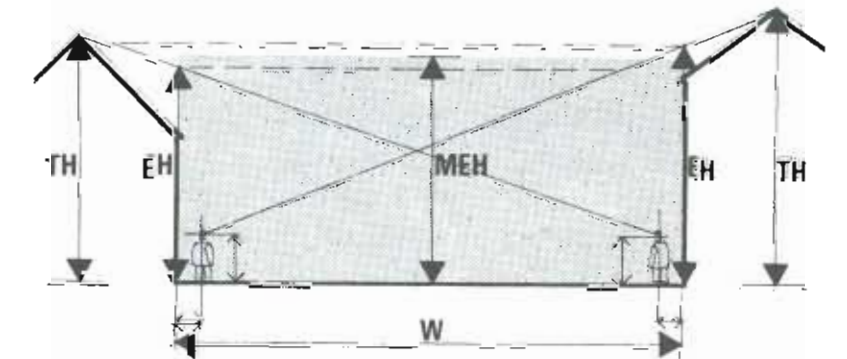

Where the two sides of a space are enclosed by pitched roofed buildings of differing 'effective heights', a 'mean effective height' may again be determined.

KEY

- TH - True height
- EH - Effective height
- MEH - Mean effective height
- W - Width of space

APPENDIX B

DESIGN THEORY

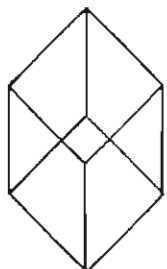

VISUAL AMBIGUITY.
Are you looking up or down at this 'cube'?

A well designed building will not be disturbing to the eye.

If the eye is disturbed, the observer will subconsciously feel uncomfortable: the building will appear ugly. Repose should be the aim.

The eye will be disturbed:—

if it cannot immediately understand what it observes, that is to say there appears to be several different interpretations of what it sees. VISUAL AMBIGUITY (All the visual clues are not given).

The eye will be disturbed:—

if the building does not appear to hang together as a complete object (A UNITY), that is if the links between the parts appear weak.

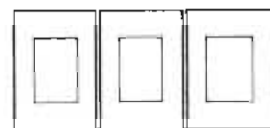

UNITY.
Strong link between elements.

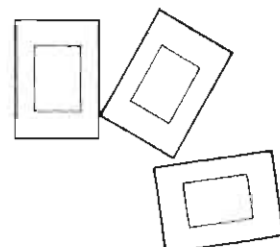

LACK OF UNITY
No apparent link between elements

A special lack of unity is the tendency to split into two parts (A DUALITY).

This elevation balances about its centre line. (there is a single axis). The composition is unified.

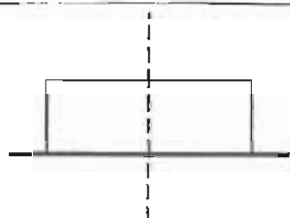

In this elevation there are two, equally strong, visual axes. There appear to be two elements loosely connected (there are two potential compositions in conflict: A DUALITY).

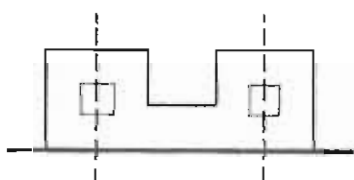

The eye wishes to separate the two elements to resolve the composition. (the central link is visually redundant).

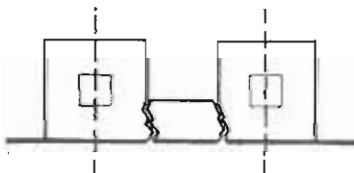

Any even number of similar components will tend to have this 'split' in the middle (AND CONSEQUENT LACK OF UNITY).

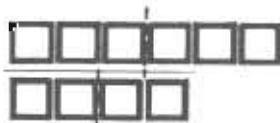

The eye will be disturbed:—



if parts of the building appear unstable or weak, even though technically it is safe.

The eye will be disturbed:—

if the composition is not in balance. The rules of visual balance are analogous to the rules of physical balance, the visual weights of areas balancing about a visual axis.

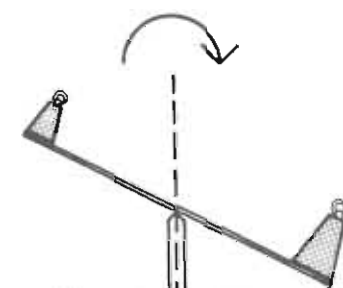

Physically unbalanced.



visual axis

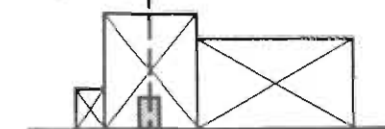

Visually unbalanced

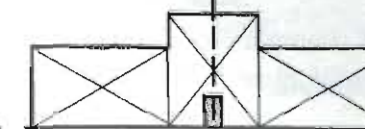

SYMMETRICAL BALANCE



ASYMMETRICAL BALANCE

With plain volumes the eye will automatically balance the composition by creating an imaginary axis through the centroid of the composition.

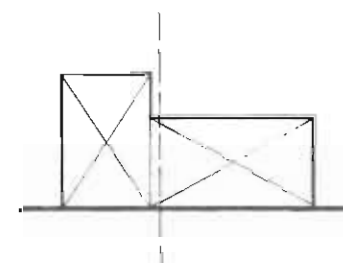

Axis through centroid

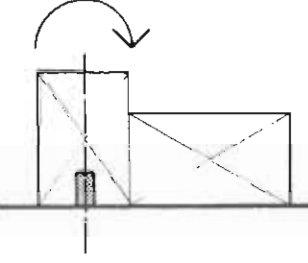

Additional axis through architectural feature, destroys the balance

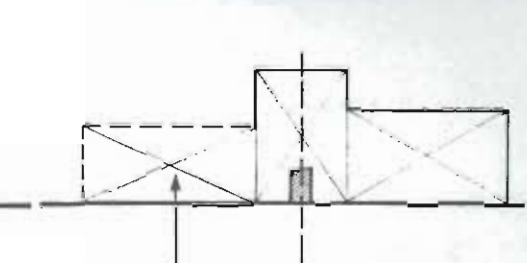

An additional area is required to regain the balance.

If a strong feature is made on the surface of the volumes, the eye will use this as the axis, the composition then may or may not balance.

The eye will be disturbed:—

if any constituent element of the building is not suitably proportioned for the design 'role' it has to perform. Proportions will vary from the perfect square to the very long rectangle, each proportional relationship having its own characteristics.

(i) SQUARES. Areas of a more or less square proportion are assertive and will draw the eye. A square, when used, will provide a focus.

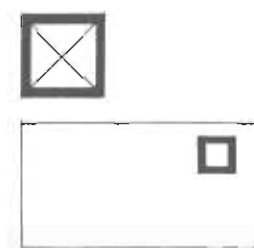

Squares should not be used in combination, because each foci will be in competition with the others.

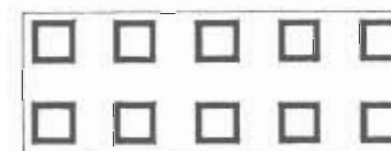

(ii) RECTANGLES. Rectangles have a directional emphasis in parallel with the major axis. The longer the rectangle, the stronger this emphasis.

(iii) ROOT 2 RECTANGLES. These rectangles are a half way condition between a square and a directionally strong rectangle; neither draw the eye nor provide strong directional emphasis and therefore present a restful shape.

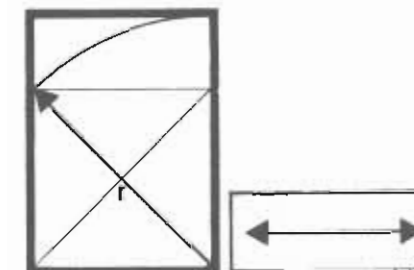

R² rectangle

Directional rectangle

The use and combination of areas of differing proportion should be governed by the visual function each is required to play, to give repose to the total composition.

This appendix is attached to the 1983 reprint as a result of requests by many visitors who come to Essex and who wish to view the results of the Design Guide policy.

The schemes are divided into three categories:

- (i) Public Sector Housing
- (ii) Private Housing Development
- (iii) Infill Schemes

1. Public Sector Housing

- | | | |
|----------------|---------------|--|
| 1. Colchester: | Dutch Quarter | This is a remarkable achievement in the re-making of an urban fabric partially destroyed during the 1950's and 1960's by the removal of 'unfit' property. First stages complete, final stages under construction (1983) located between High Street and River Colne. |
| | Architects | K. Bell, A.R.I.B.A., Borough Architect.
R. Rose, A.R.I.B.A., Job Architect. |
| 2. Basildon: | Noak Bridge | The entirely 'new village' of Noak Bridge within Basildon New Town — north of the A.127 at the junction of the A.176. |
| | Architects | Department of Architecture, Basildon Development Corporation. |
| 3. Halstead: | Market Place | 3-storey medium/high density scheme on sloping 1 acre site to the north of the Market Place for Braintree District Council. This site is illustrated on page 109 as a case study. |
| | Architects | Clifford Culpin & Partners, Richmond, Surrey. |

2. Private Sector Housing

- | | | |
|---------------------------|-------------------------|---|
| 1. Brentwood: | Sawyers Hall Lane | 64 houses on spine cul-de-sac and mews courts. Effective arrangement gives urban enclosure in spite of all houses being detached. Good detailing and materials. North of old A.12 east of Ongar Road. |
| | Architects | D. Ruffle Associates, Chelmsford. |
| | Developer | Countryside Properties, Billericay. |
| 2. Chelmsford: | Galleywood | Low density scheme includes retention of existing trees and roadside tree planting. Effective use of private drives. Well detailed and good materials. Located on B.1007 road to Billericay. |
| | Architects | J. S. Wood & Partners, Shenfield, Chartered Surveyors. |
| | Developer | Countryside Properties, Billericay. |
| 3. Kelvedon Hatch: | | Mixed density scheme incorporating small terraced units to 4-bedroom detached around 'village green'. Located on A.128 Brentwood/Ongar road. |
| | Architects & Developers | Countryside Properties, Billericay. |
| 4. Colchester: | Braiswick | High density scheme of semi-detached and detached houses. Mid price range, good choice from cheap range of materials. On Fernlea Road off A.133 Sudbury Road. |
| | Architect & Developer | Messrs. Comben Homes, Bristol. |
| 5. Witham: | 'The Grove' | Extensive medium density low cost pioneer scheme of 1974/on showing the 'resurrection' of street design; suffers from cheap materials and details. South of Newland Street, east of Grove Road. |
| | Designers & Developers | A. Reason Homes, Sudbury. |
| 6. South Woodham Ferrers: | | South Woodham Ferrers is an Essex County Council sponsored development to expand the existing settlement to a country town of approximately 17,500 population. There is a wide variety of schemes at various densities, some of which are listed below. |

- | | | |
|------------------------------------|-------------------------|--|
| (a) Abbotsfield Estate | Architects
Developer | Medium density scheme north/west of the roundabout at the junction of Inchbonnie Road and Ferrers Road.
D. Walden Associates, Chelmsford.
D. L. & P. Luck, Hornchurch. |
| (b) 'Fenfields' | Architects
Developer | 18 detached and semi-detached houses in development containing early mews court (now incorporated within adjoining development).
Stanley Keen & Partners, Brentwood.
Endersby Properties. |
| (c) Collingwood Road | Architects
Developer | High density scheme of 2-bedroom terrace houses and flats facing school playing field, near junction of Collingwood Road and Broughton Road.
Steel Bretman & Partners, Buntingford.
Halrod Developments, Billericay. |
| (d) Broughton Road 'The Anchorage' | Architect & Developer | Attractive low density scheme of detached houses on single track road.
Messrs. Comben Homes, Bristol. |

3. Infill Schemes

- | | | |
|-----------------------|--|--|
| 1. Great Chesterford: | Developers
Designers | Numerous small infill schemes within village dating from early 1970's.
J. Brown, Saffron Walden.
Plumb Bros., Gt. Chesterford.
R. Halsey, Saffron Walden.
Lynn & Company, Debden. |
| 2. Ingatestone: | 'Chapel Croft'
Architects
Developers | Small high density scheme of semi-detached houses in village centre north of Market Place. Good materials and detailing.
D. Ruffle Associates, Chelmsford.
Countryside Properties, Billericay. |
| 3. Clavering: | Designer | 'Village edge' scheme, early development illustrated in Design Guide opposite page 61.
J. S. Wood & Partners, Shenfield. Chartered Surveyors. |
| 4. Broomfield Green: | Architect
Developers | Small scheme on village green opposite church.
John S. Wood & Partners, Shenfield.
Countryside Properties, Billericay. |
| 5. Chelmsford: | Odeon Roundabout Parkway
Architect & Developers | Small scheme of 3-storey flats using land that prior to the policy could not be developed.
R. W. Chandler & Sons, Chelmsford. |
| 6. Newport: | Designer
Developer | 12 houses on the High Street to fill gap in front of large housing estate.
Lynn & Company, Debden.
Piggot Bros. |
| 7. Saffron Walden: | Designer
Developer
Designer
Developer | (a) New courtyard to south of Church Street, mixture of 3-storey houses and flats.
R. Halsey, Saffron Walden.
Plumb Bros., Gt. Chesterford.
(b) South end of Gold Street. High density 3-storey town houses and flats.
R. Halsey, Saffron Walden.
J. Brown, Saffron Walden. |

ACKNOWLEDGEMENTS

The Practice Notes which follow the policy statement approved by the County Planning Committee, indicate the thinking behind the policy and show by examples and case studies how the policy can be implemented. We believe that within the policy framework the scope for the skilled designer is enlarged and there are now greater opportunities for imaginative layout and design of housing estates which will add to the appearance of the towns and villages in Essex. The Design Guide is not "pie in the sky". It indicates, we hope, in a practical way how, without increasing overall costs, developers will be able to give house owners better value for their money. This means in effect better housing within an improved environment, and seen to be part of the Essex building tradition. Before this Guide was issued a draft was circulated to representatives of local and national bodies including Architects, Surveyors, Estate Agents, Civic Societies, Building Societies, local authorities and statutory undertakers, builders and developers. As a result of this consultation, supplemented by numerous meetings and discussions, amendments have been made. We are grateful to those individuals and organisations who spared time to comment, criticise and advise on the draft. Their names appear on the following page. The work on this Guide of course has been a team job and I must acknowledge the help given by L. Johnson, Esq., C.Eng., M.I.C.E., M.I.Mun.E., and D. Baldwin, Esq., C.Eng., M.I.C.E., M.I.Mun.E., of the County Surveyor's Department, also P. S. Mason, Esq., A.R.I.C.S., the Deputy Chief Quantity Surveyor from the Department of the County Architect. The leader of the team and prime mover from my Department was Melville Dunbar, Dip.Arch.A.A.Dipl.T.P., R.I.B.A., who was assisted by Michael Shepherd, Dipl.T.P., R.I.B.A., Anthony Aspinall, A.A.Dipl., R.I.B.A. and David Stenning, Dip.Arch. Graphics and additional drawings by Christopher Cotton, Dip. A.D. and David Pickett.

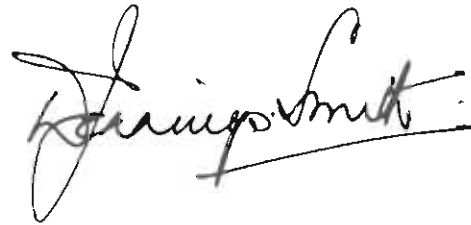

D. Jennings Smith, Dip.Arch.F.R.T.P.I., R.I.B.A.
COUNTY PLANNER

I would wish to further acknowledge the comments and assistance given by the following bodies:

Aluminium Window Association.
Associated Planning Consultants.
Michael Blee and Associates, Chartered Architects.
Brick Development Association.
Stanley Bragg & Associates, Chartered Architects.
Cambridgeshire and Isle of Ely County Council.
John Carter, Architect.
Cheshire County Council.
Civic Trust.
C. J. Collins, A.R.I.B.A., F.S.I.A.
Council for the Protection of Rural England.
Countryside Properties Limited.
County Borough of Dudley.
County Borough of Southend-on-Sea.
County of Lincoln, Parts of Lindsey.
County Planning Officers Society
Crittall Hope Limited.
Clifford Culpin and Partners, Chartered Architects & Planners.
Darbourne & Darke, Chartered Architects.
Department of the Environment.
Devon County Council.
Eastern Electricity.
Eastern Gas.
Essex Archaeological & Historical Congress.
Essex Water Company.
Essex County Fire Brigade.
Fairview Estates (Enfield) Ltd.
Frederick Gibberd & Partners, Chartered Architects and Planners.
Glamorgan County Council.
Gloucestershire County Council.
Robert Hubbard.
R. C. Houghton, Dip. Arch., A.R.I.B.A.
Donald W. Insall and Associates, Chartered Architects and Planners.
Kent County Council.
S. H. Landsdell & Sons Ltd.
London Borough of Redbridge.
London Brick Company Limited.
Milton Hall (Southend) Brick Co. Ltd.
R. A. Moss, Dip. T.P., A.M.T.P.I.
National Council of Women of Great Britain.
National Federation of Building Trades Employers.
National House Builders Registration Council.
Nationwide Building Society.
North Riding of Yorkshire.
Oxley Cherry Associates, Chartered Architects.
Arthur Paxton.
The Post Office—Telephones Branch.
R.I.B.A. Chelmsford Chapter.
R.I.B.A. Colchester and District Chapter.
R.I.B.A. Southend-on-Sea District Chapter.
R.I.B.A. West Essex Branch.
Saffron Walden Countryside Association.
St. John's Residents' Association.
Strutt and Parker, Chartered Surveyors.
The Architectural Press Ltd.
The House-Builders Federation.
White & Miles, Chartered Architects & Planners.
G. Wimpey & Co. Ltd.
G. P. Woodford, B.A., Dip.I.U. (Paris), M.R.T.P.I.
World of Property Housing Trust.
The officers of the District Councils and those of the Basildon and Harlow Development Corporations.

Photography by Michael Etridge

BIBLIOGRAPHY

- County of Essex Development Plan and Written Statement First Review. 1964 County Council of Essex
- Homes for Today and Tomorrow. M.H.L.G. 1961 H.M.S.O.
- Planning Bulletin 26—New Housing and Road Widths. 1972 D. of E.
- Development Plan—A manual of form and content. 1970 M.H. L.G.
- Planning Bulletin 2—Residential areas Higher densities 1962 M.H. L.G.
- Sunlight and Daylight Bulletin D. of E. 1971 H.M.S.O.
- Planning Bulletin 5—Planning for Daylight and Sunlight. M.H. L.G. 1964 H.M.S.O.
- Housing—The home in its setting. 11.9.1968 and 25.9.1968 The Architects Journal.
- Co-ordination of Underground Services on Building Sites—The common trench—Ministry of Public Buildings and Works, Directorate of Building Development. 1968 H.M.S.O.
- Report of Joint Committee on Location of Underground Services. 1963 Institution of Civil Engineers.
- Provision of telephone facilities on new housing estates. 1971 H.M.S.O.
- Design Bulletin 12—Cars in Housing/2 D. of E. 1971 H.M.S.O.
- Department of the Environment Circular 79/72—Childrens' Play Space 1972 H.M.S.O.
- Design Bulletin 27—Children at Play D. of E. 1973 H.M.S.O.
- Fire Prevention Guidance Notes 2.6 1973 County Council of Essex.
- Department of the Environment Circular 32/72 Highways Act 1959, Street widths for New Streets. : Byelaws 1972 H.M.S.O.
- Highways Act 1959 1959 H.M.S.O.
- Town and Country Planning Act 1971. 1971 H.M.S.O.
- The National Building Regulations. 1972 H.M.S.O.
- The Guide to the Building Regulations by A. J. Elder. 1972 Architectural Press.
- Ministry of Housing and Local Government Circular 32/67—Telephone facilities on New Housing Estates. 1967 H.M.S.O.
- Report on Planner Attitudes to the 'Small Home' concept. 1971 The Housing Research Foundation.
- Design Bulletin 25—The Estate outside the dwelling. D. of E. 1972 H.M.S.O.
- Domestic Interior Planning. 1971 Nat. Council of Women of Gt. Britain.
- The Density form and character of Residential Development. 1962 County Council of Essex.
- Notes for Guidance of Applicants for Planning Permission. 1969 County Council of Essex.
- Development Control Procedures 1969. 1969 County Council of Essex.